

Códigos de Opção	
C25	Limpador do Vidro Traseiro
C49	Desembaçador do Vidro Traseiro
C60	Condicionador de Ar
CD4	Temporizador do Limpador de Pára-brisa
W8X	Previsão para Instalação de Rádio
U16	Tacômetro
LNL	Motor 1.0 Flex
NF2	Motor VHC 1.0 Gasolina Com Sensor Lambda Aquecido
L19	Motor VHC 1.0 Gasolina
L11	Motor VHC 1.0 Gasolina Exportação
LQS	Motor VHC 1.4 Gasolina, Local / Exportação

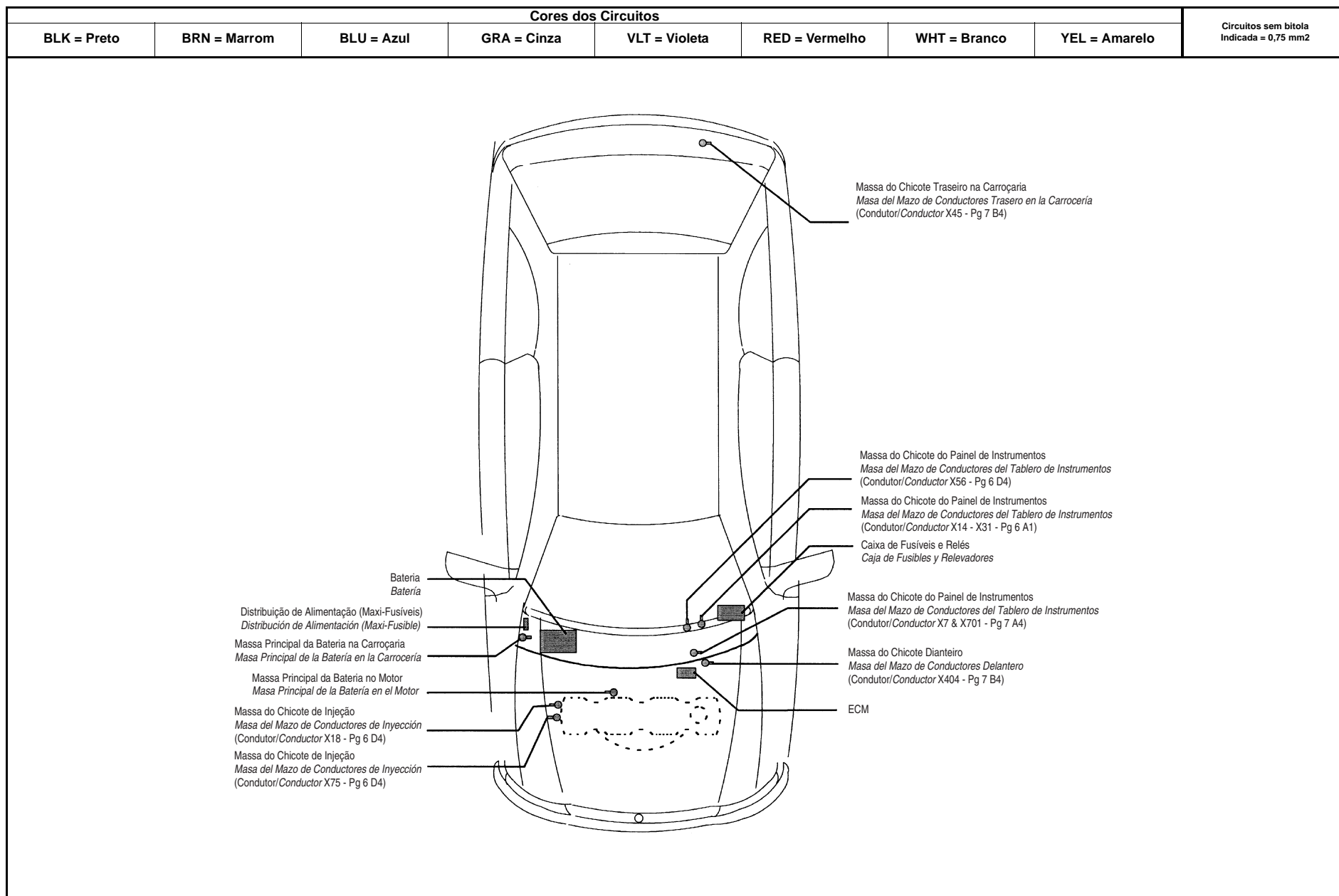

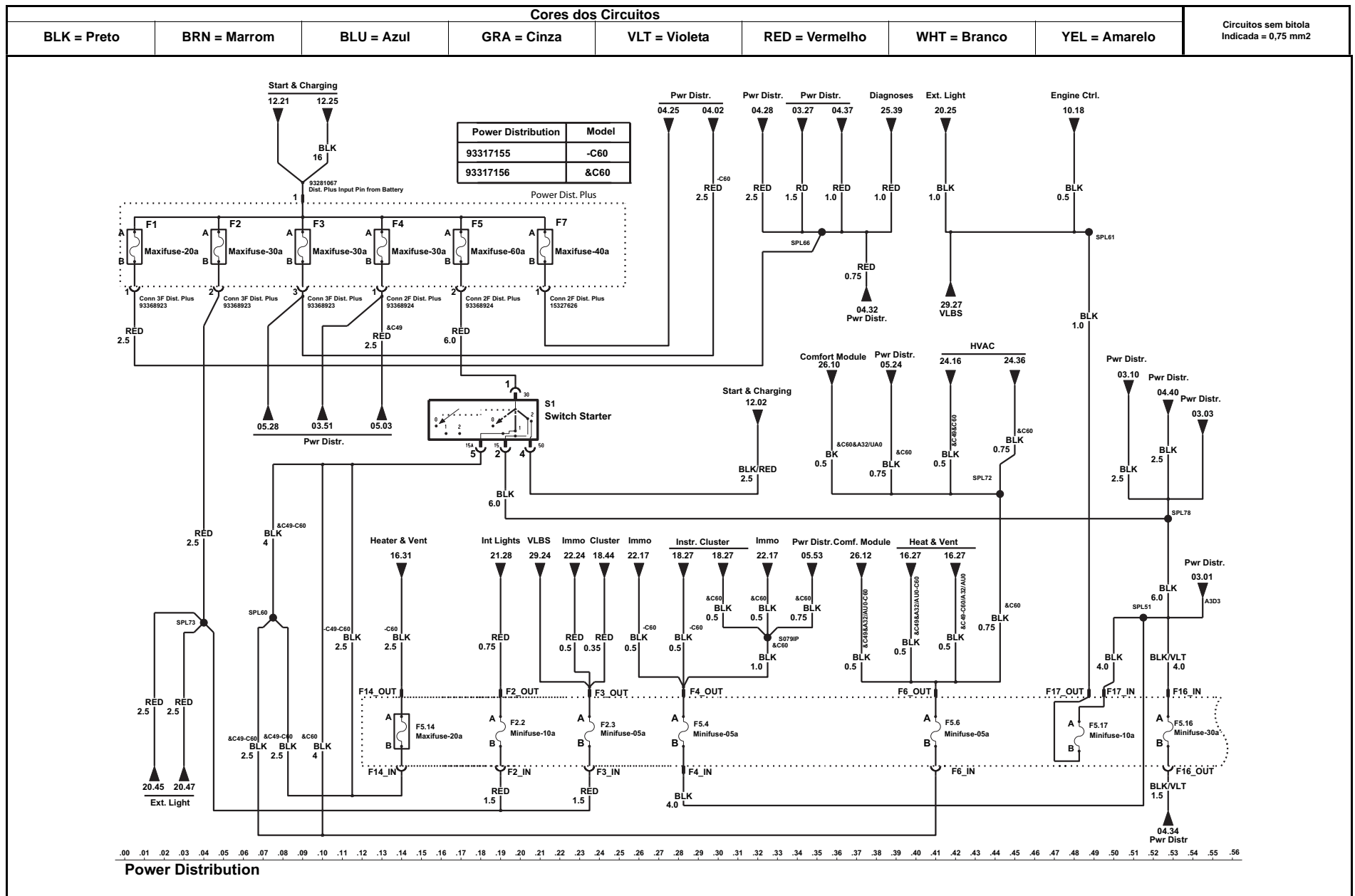

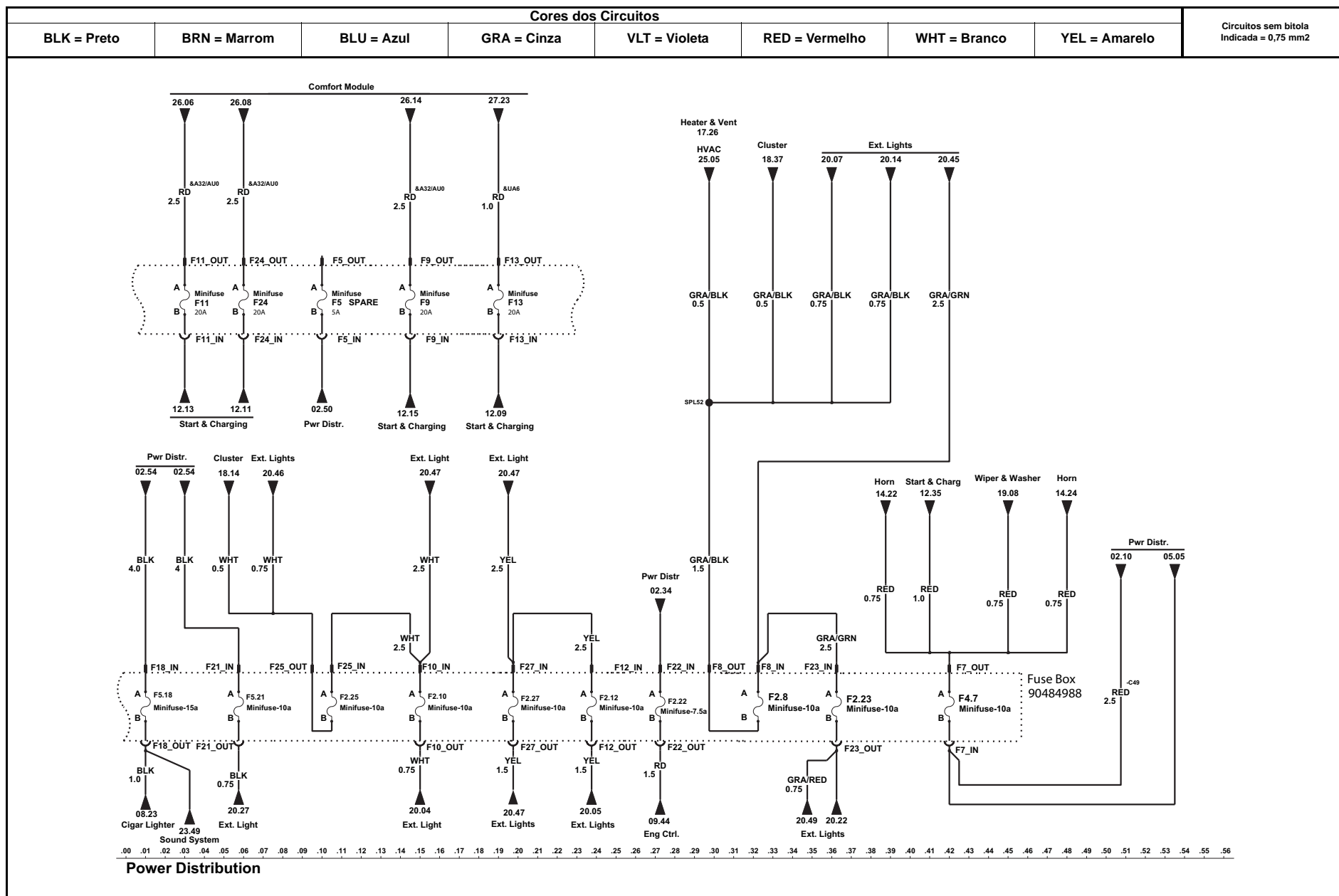



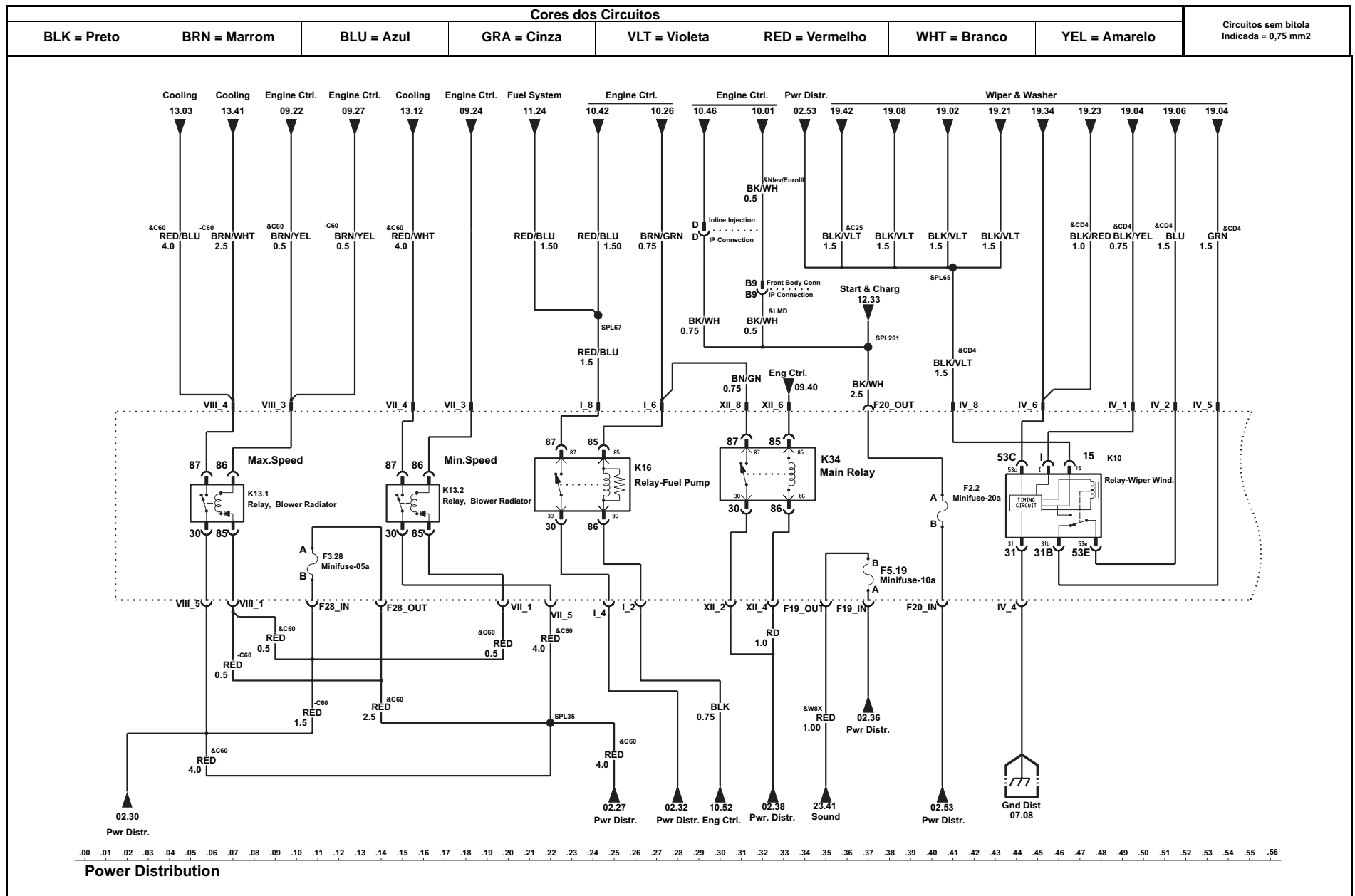

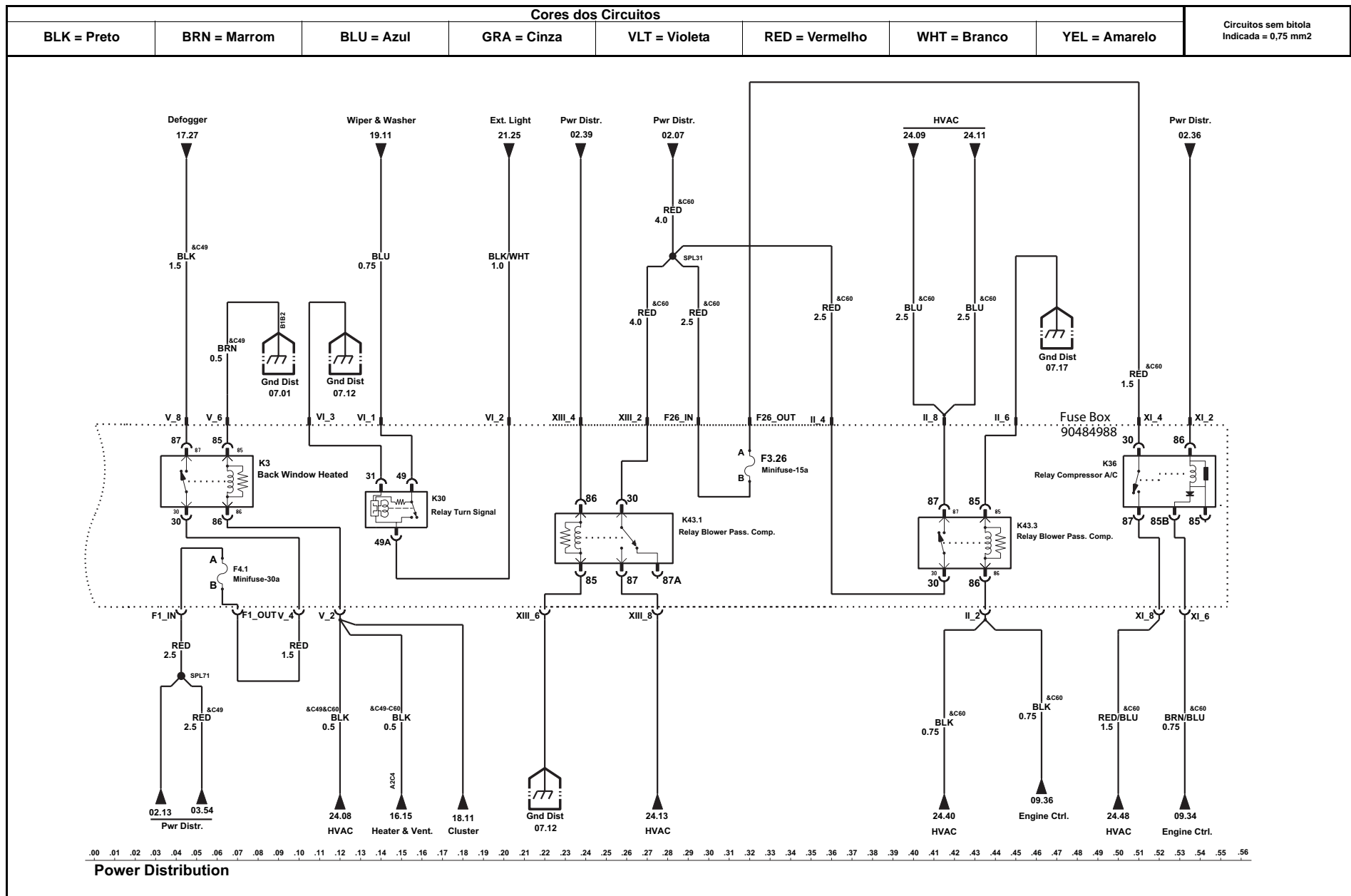

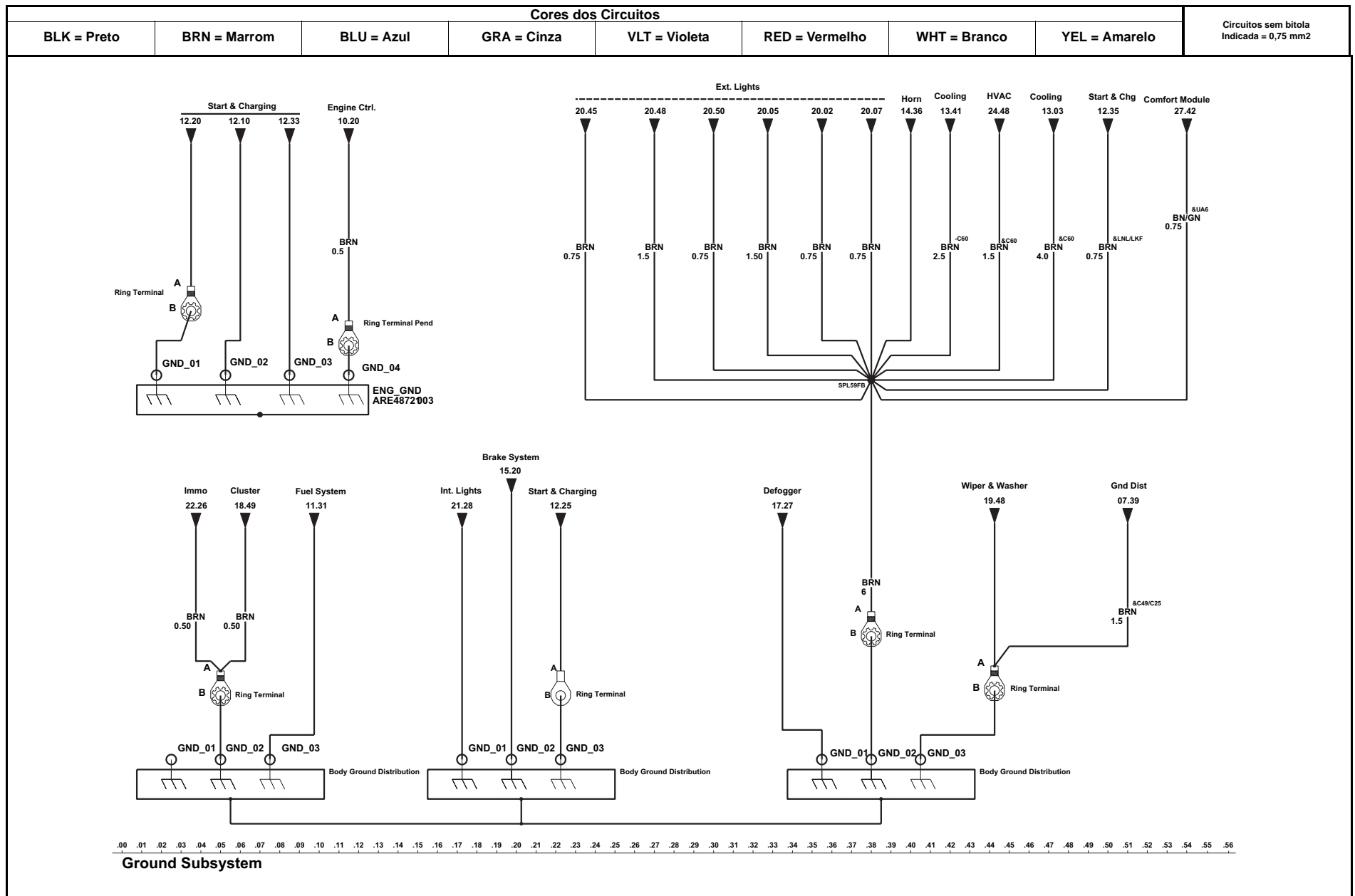

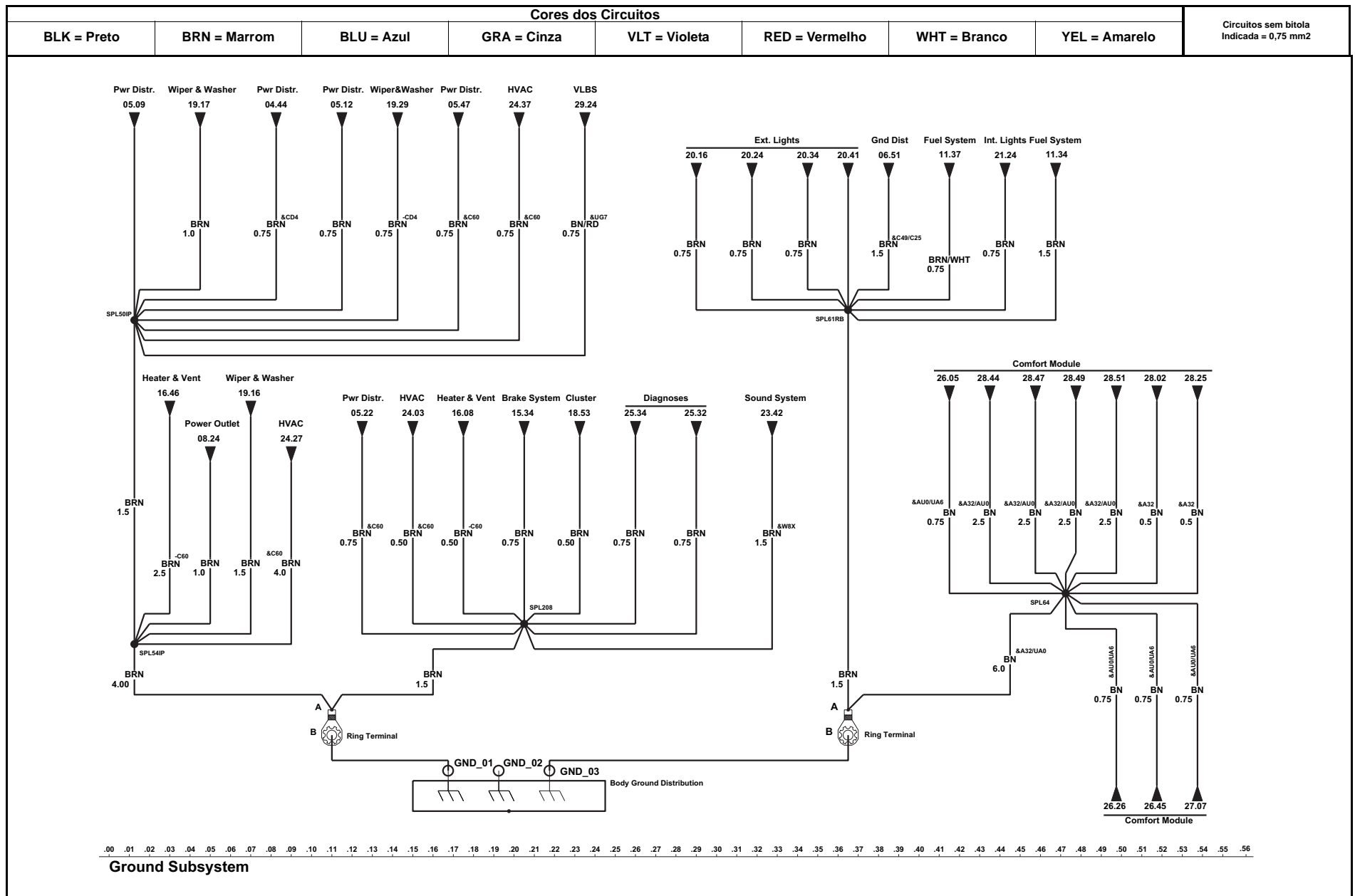

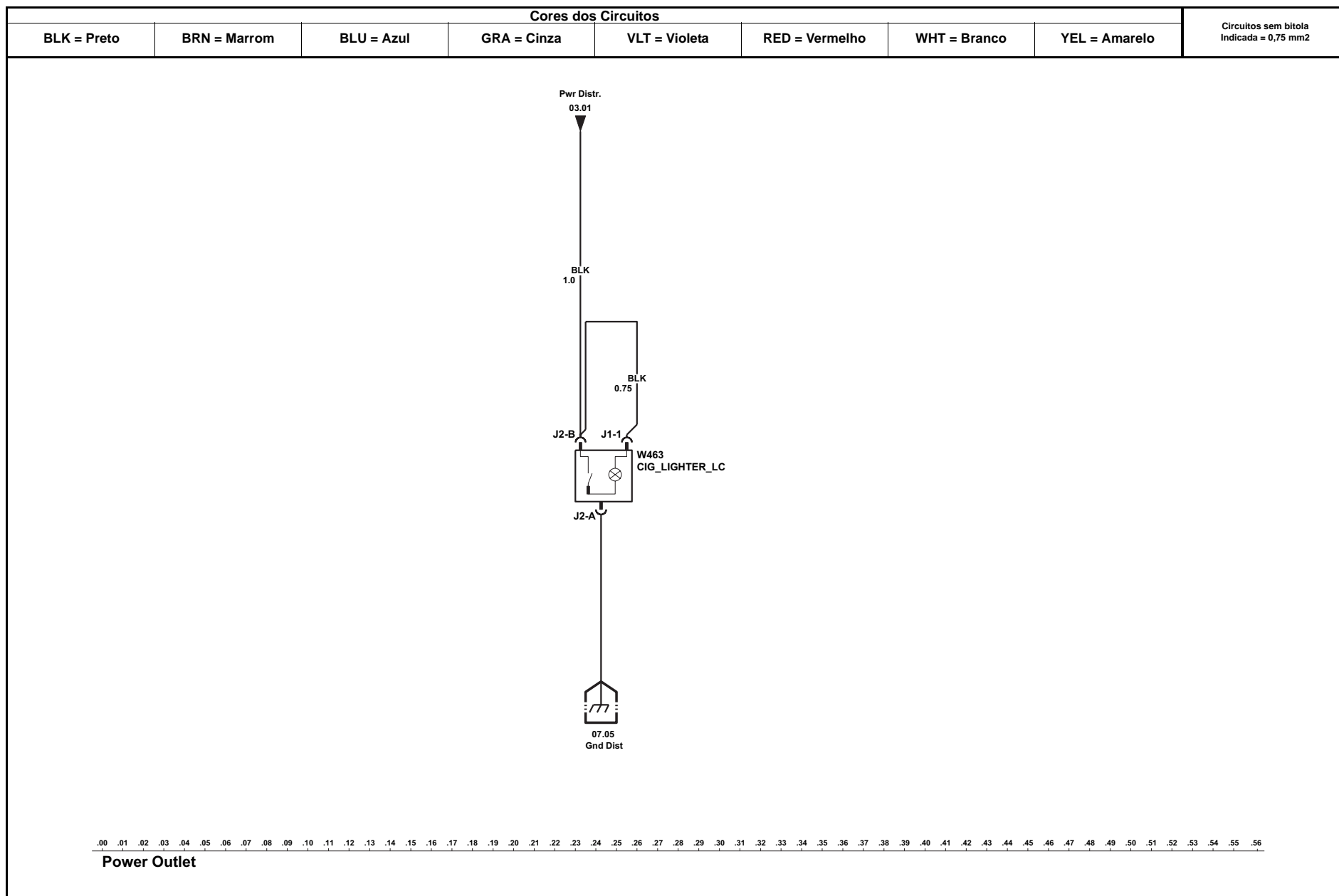

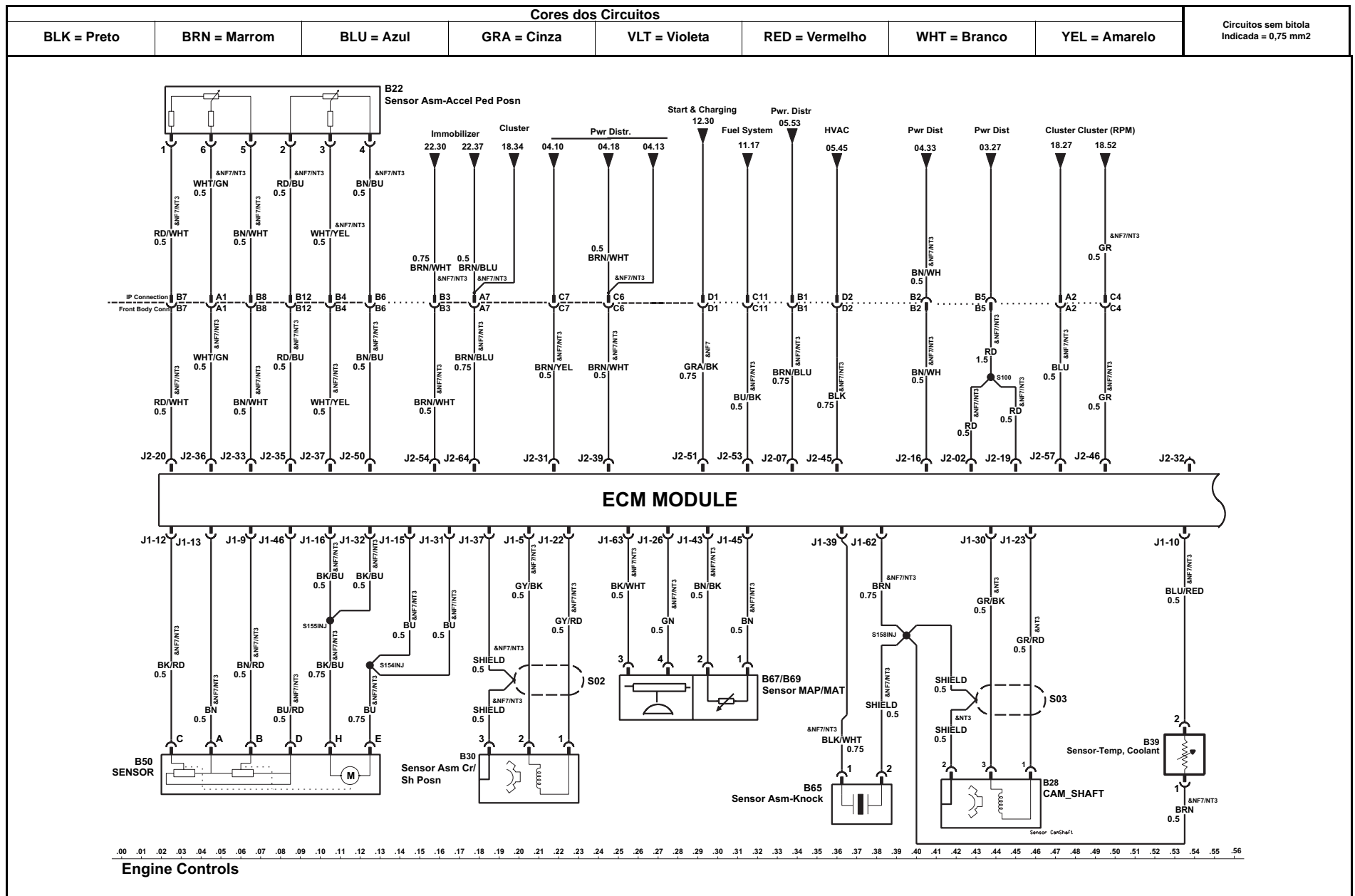

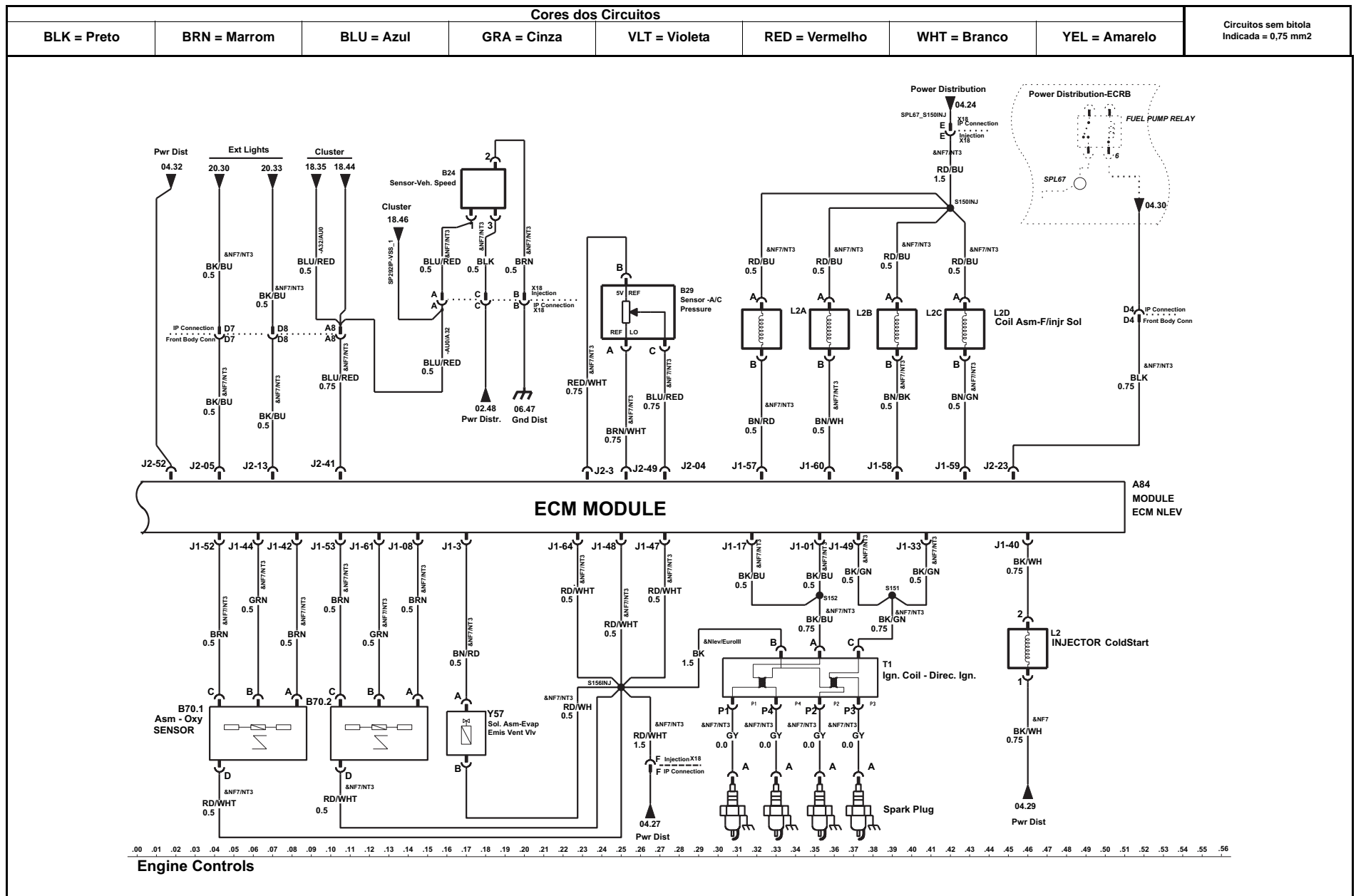

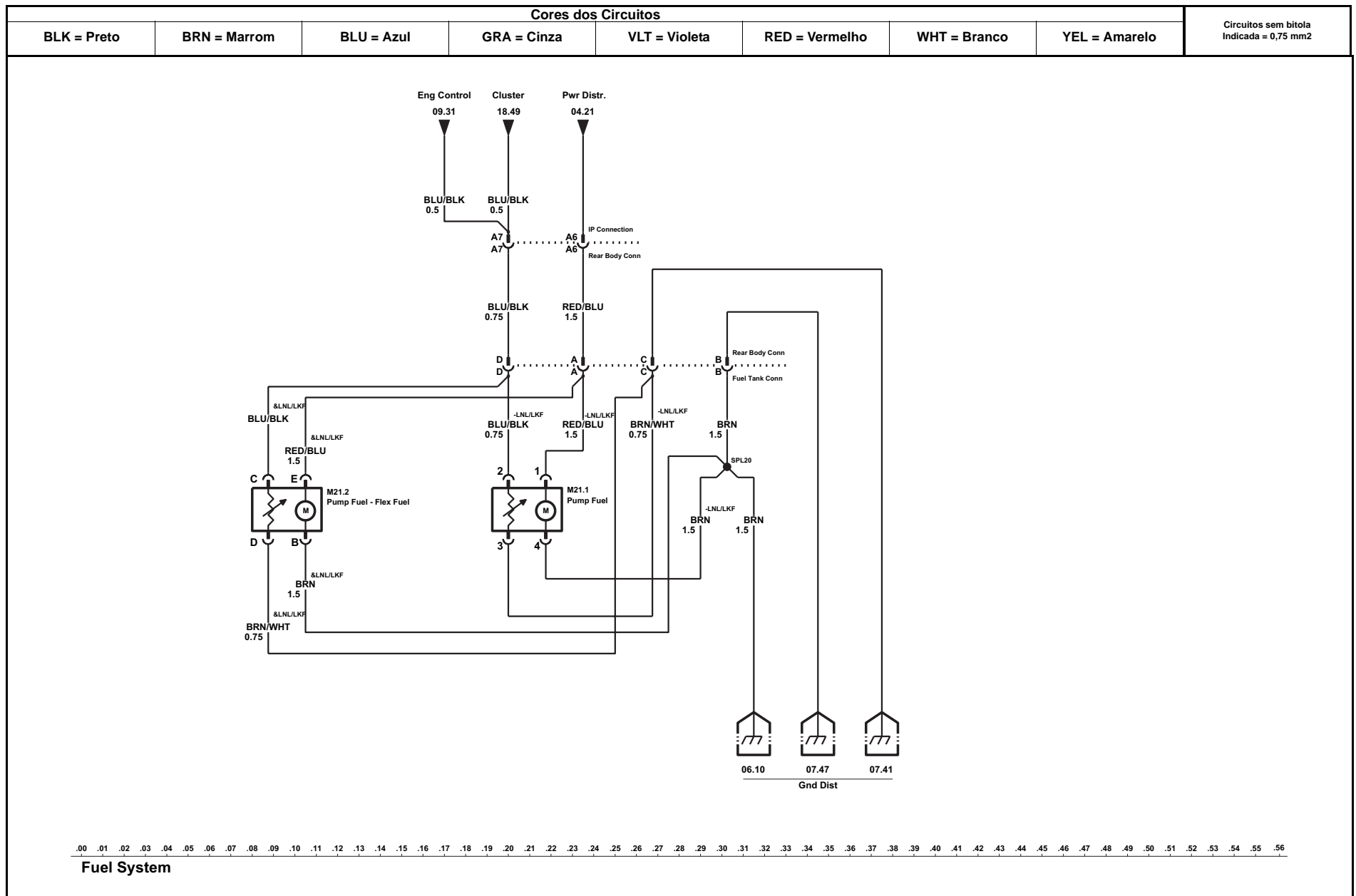

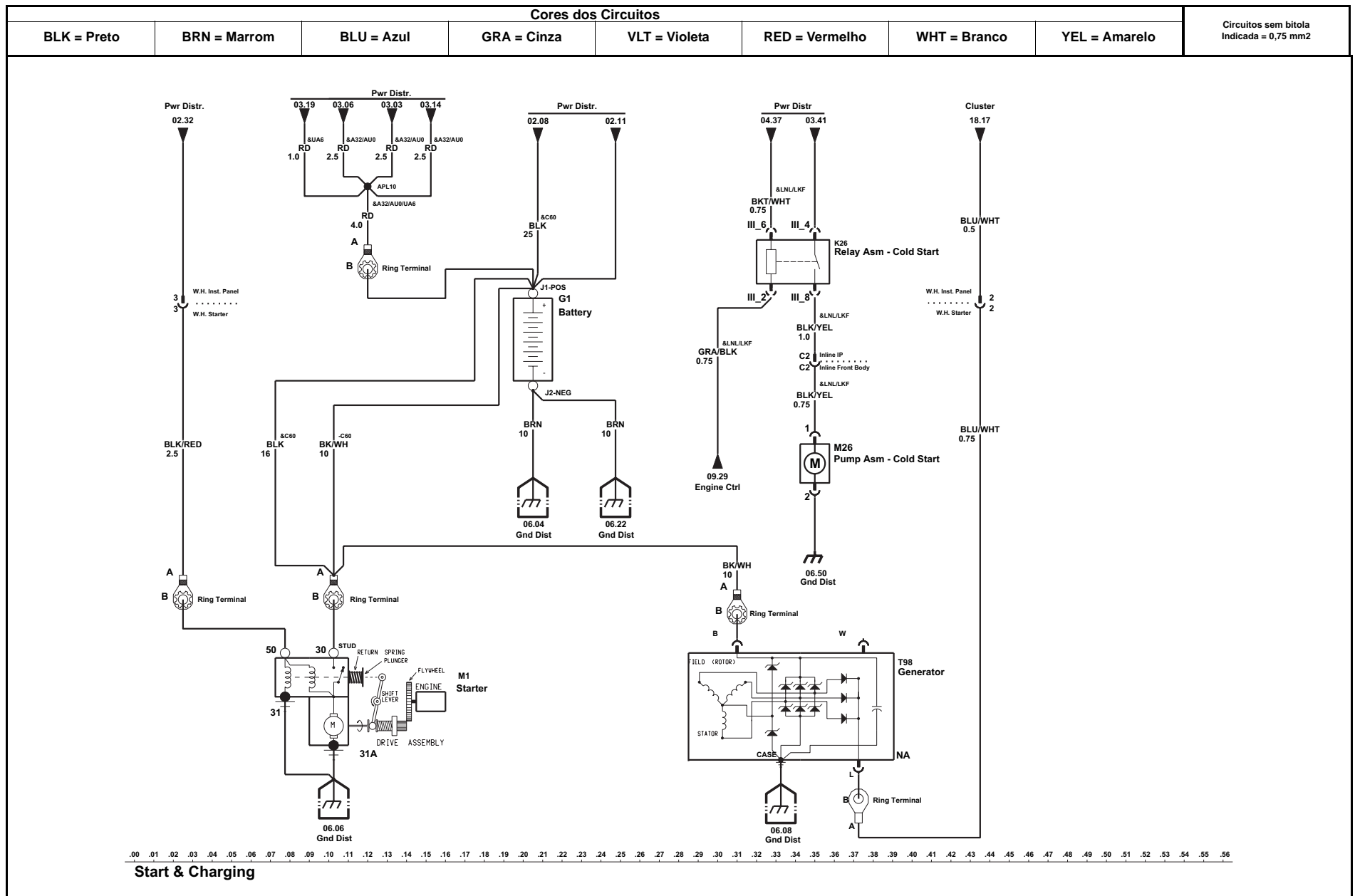

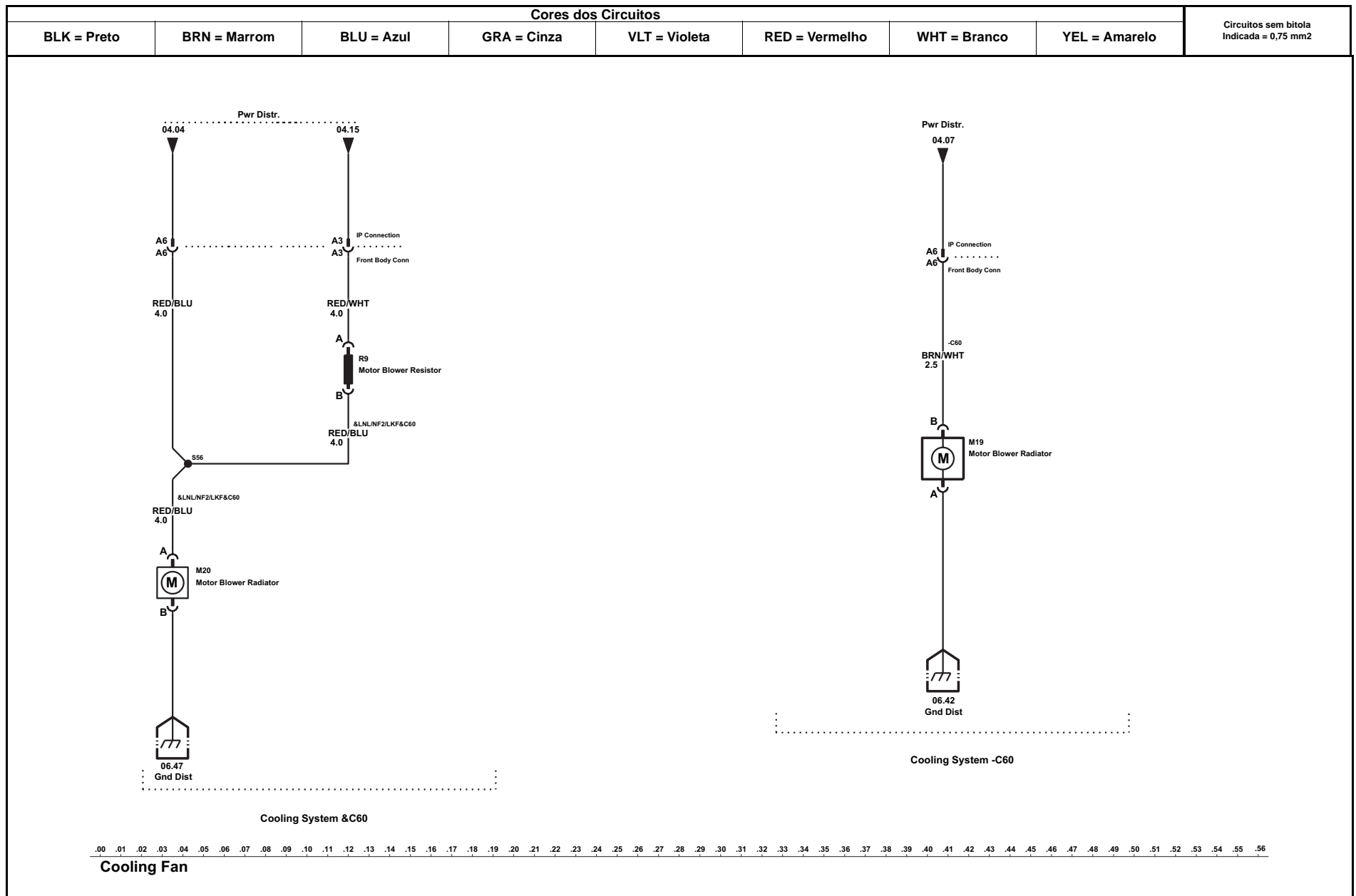

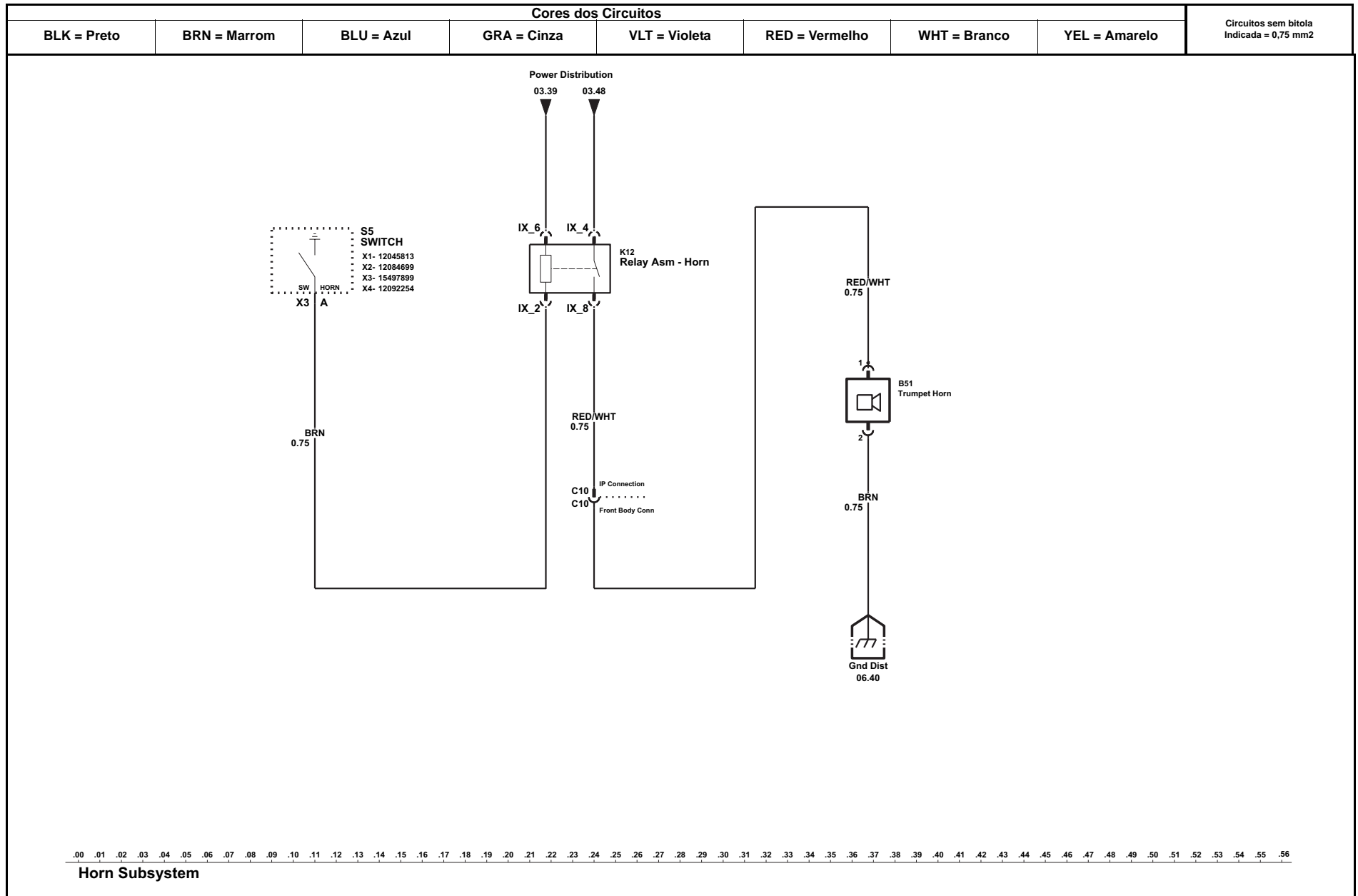

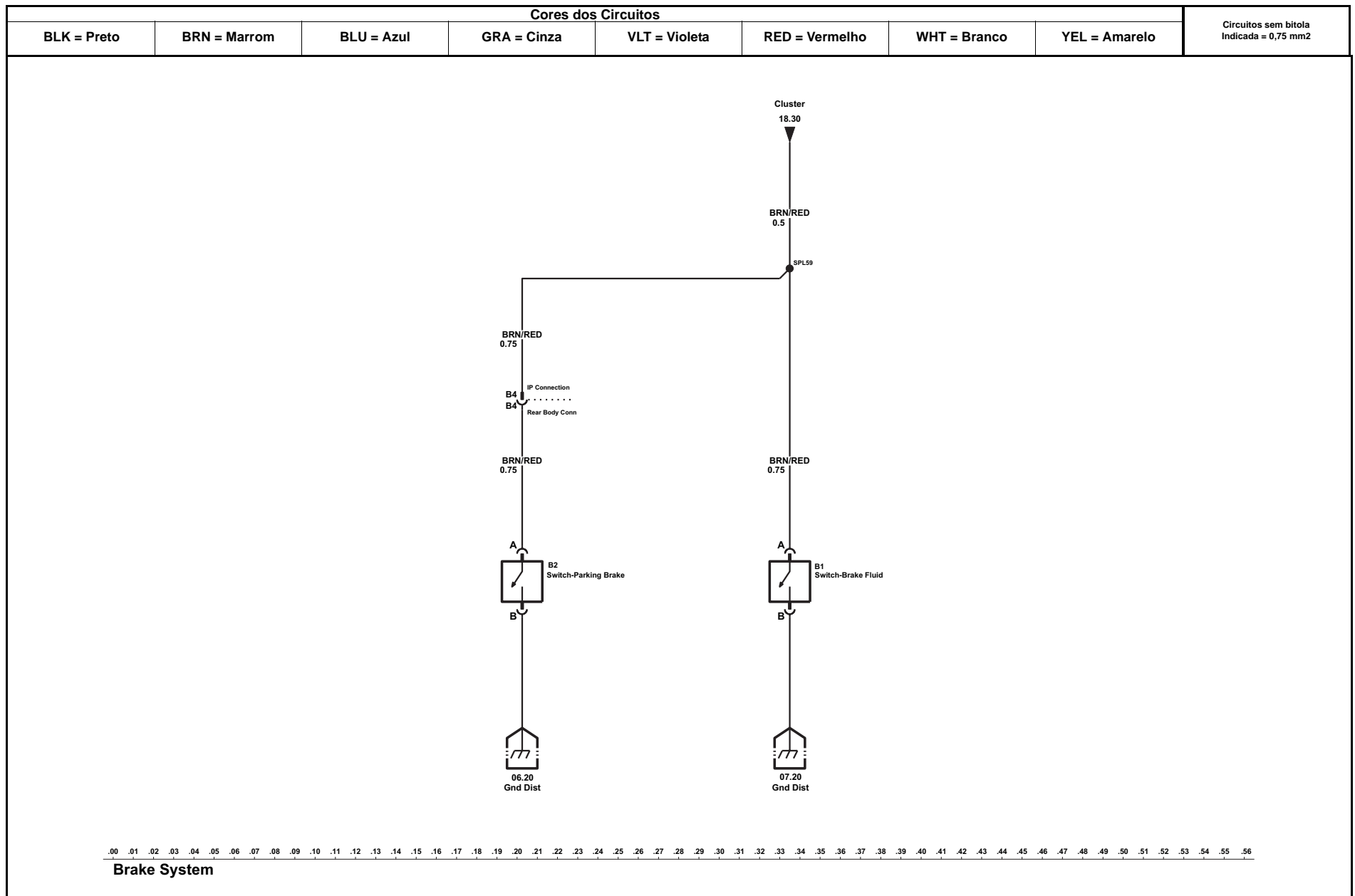

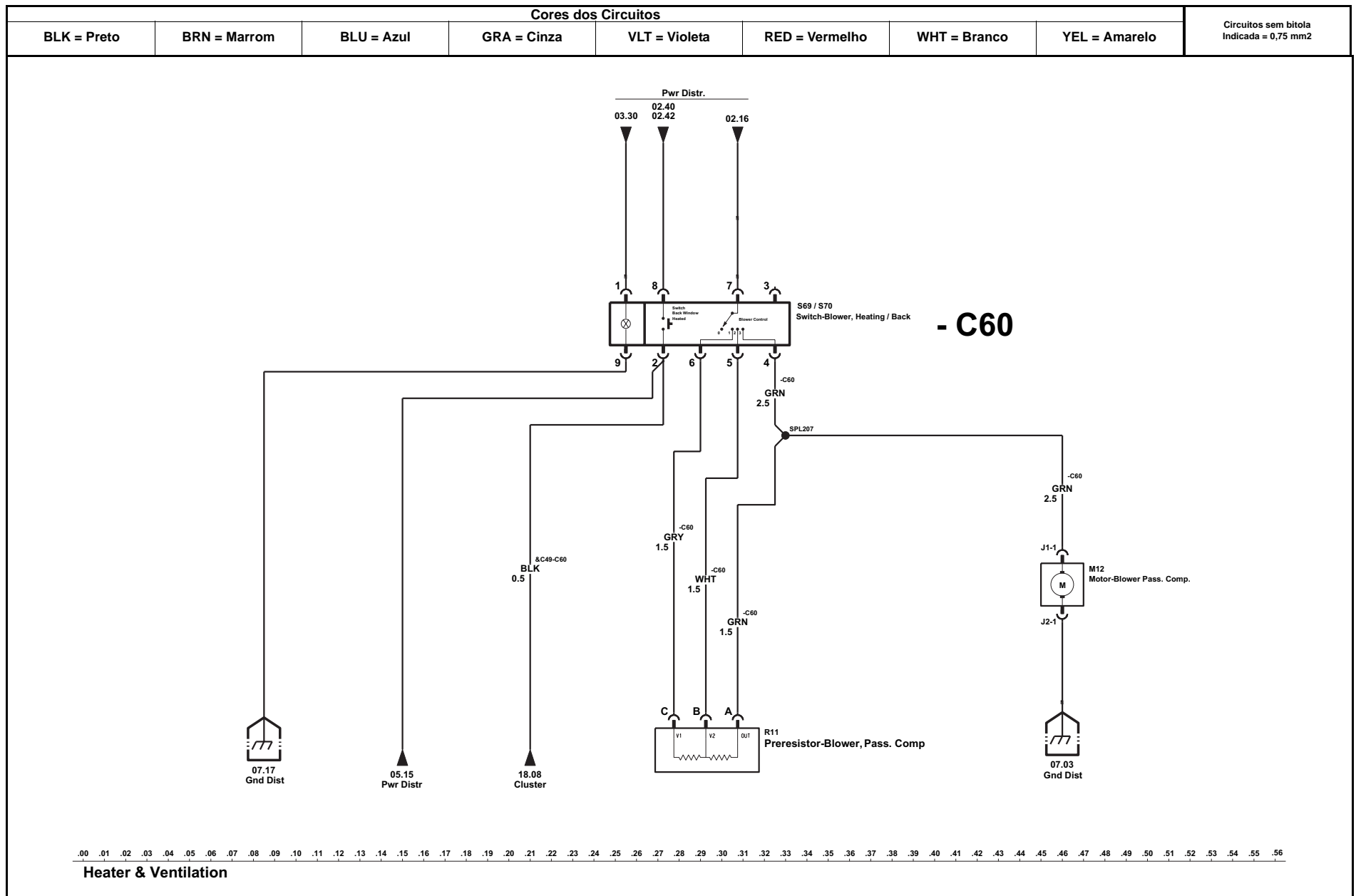

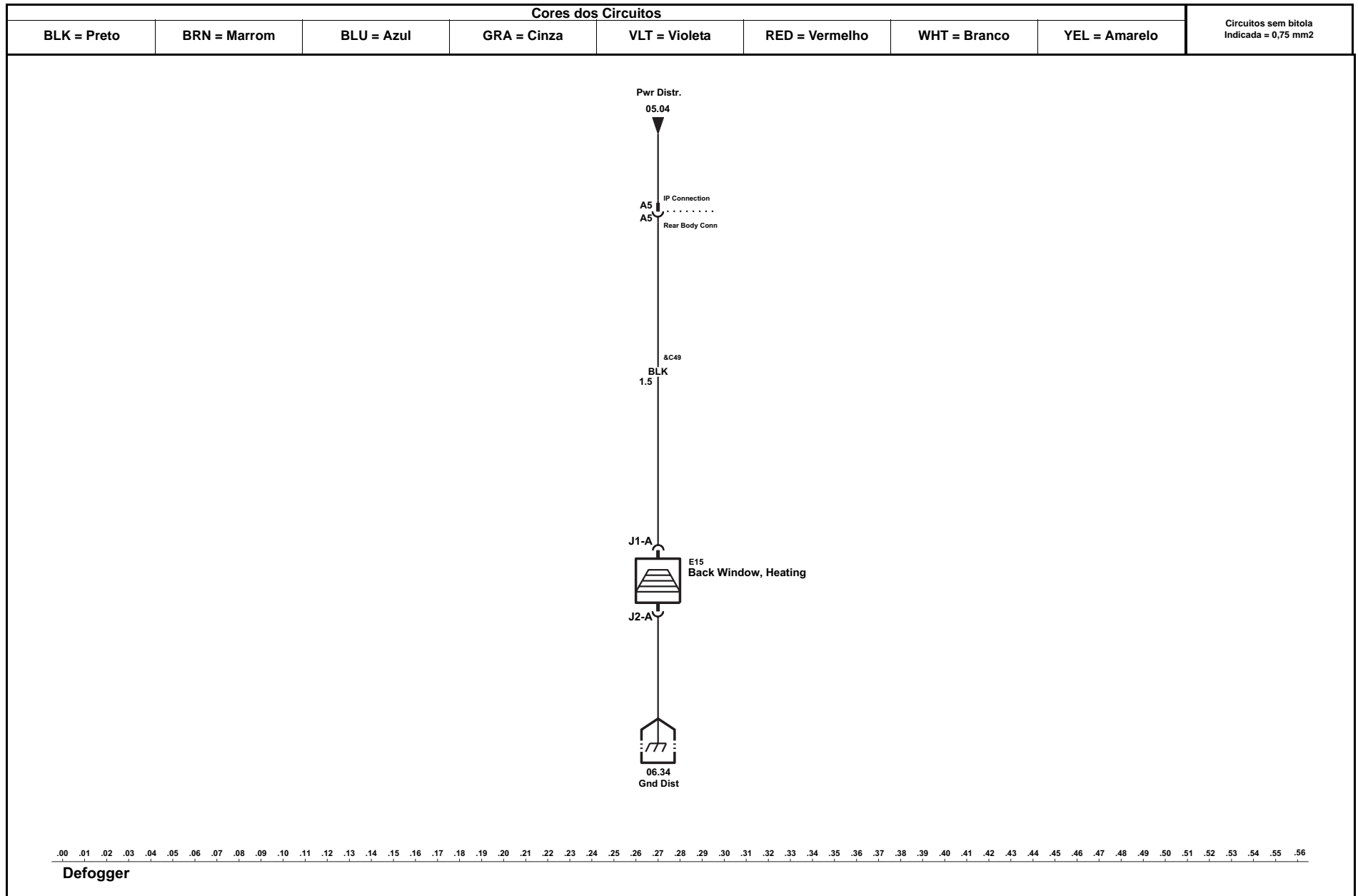

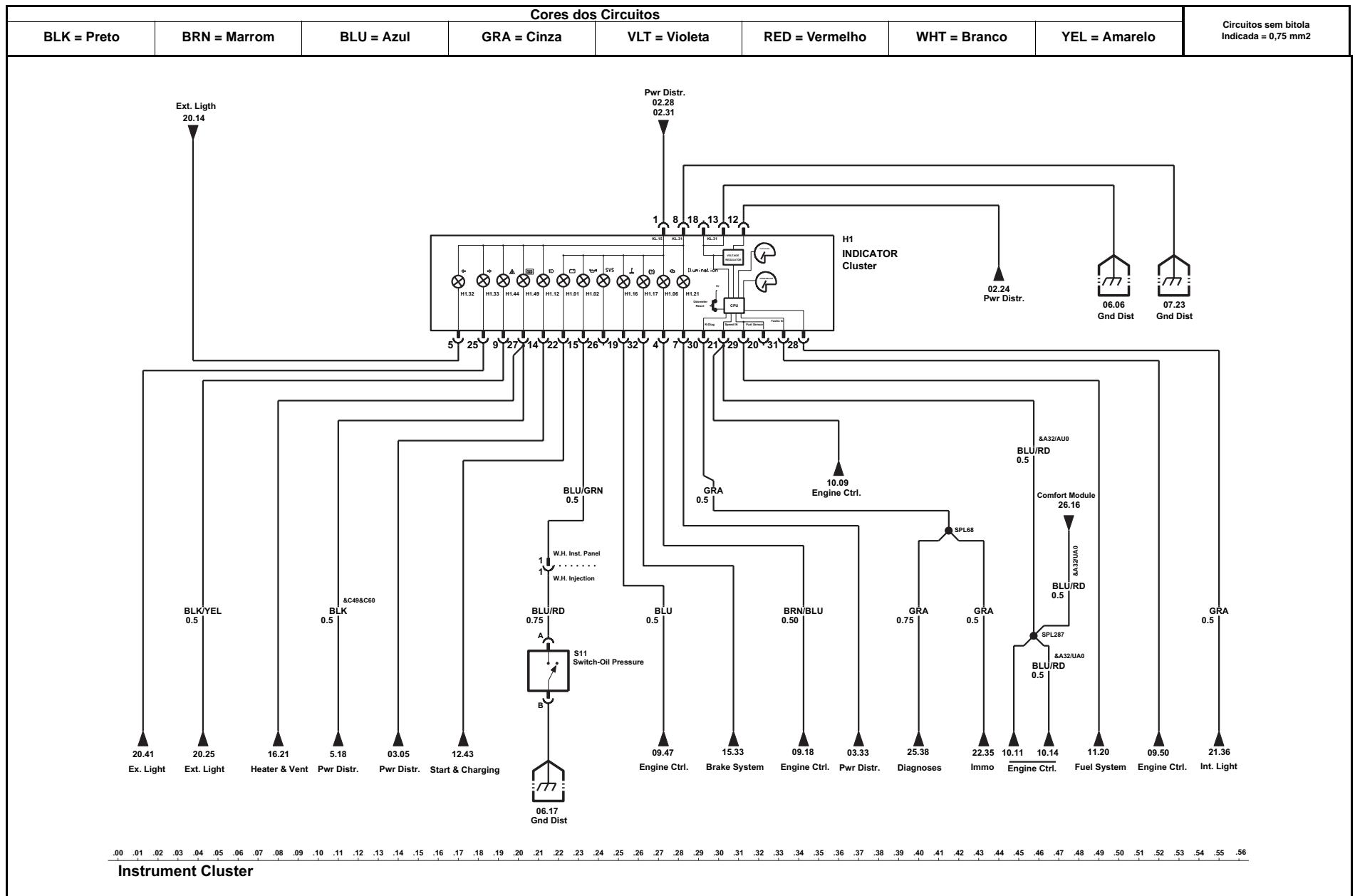

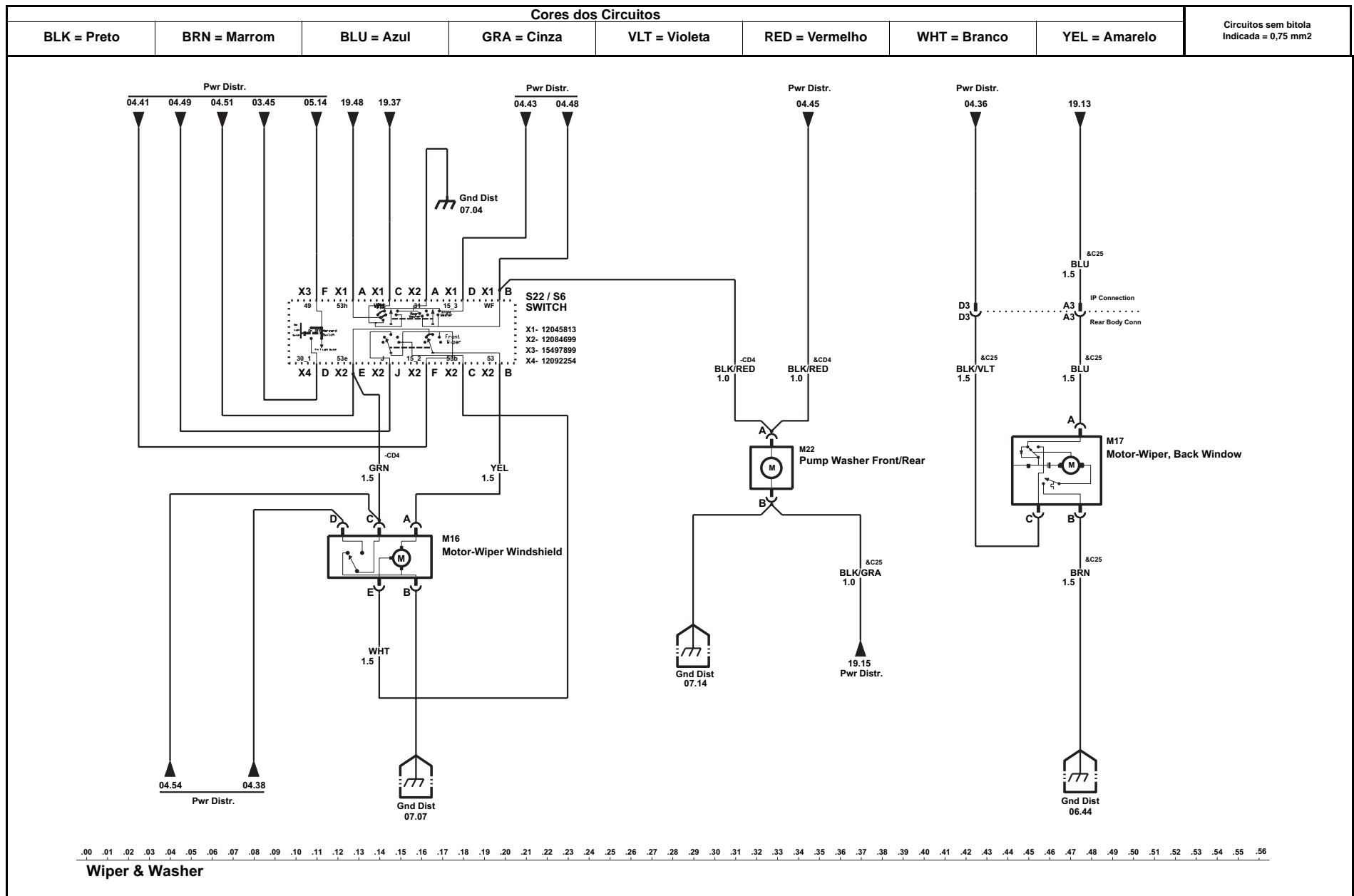

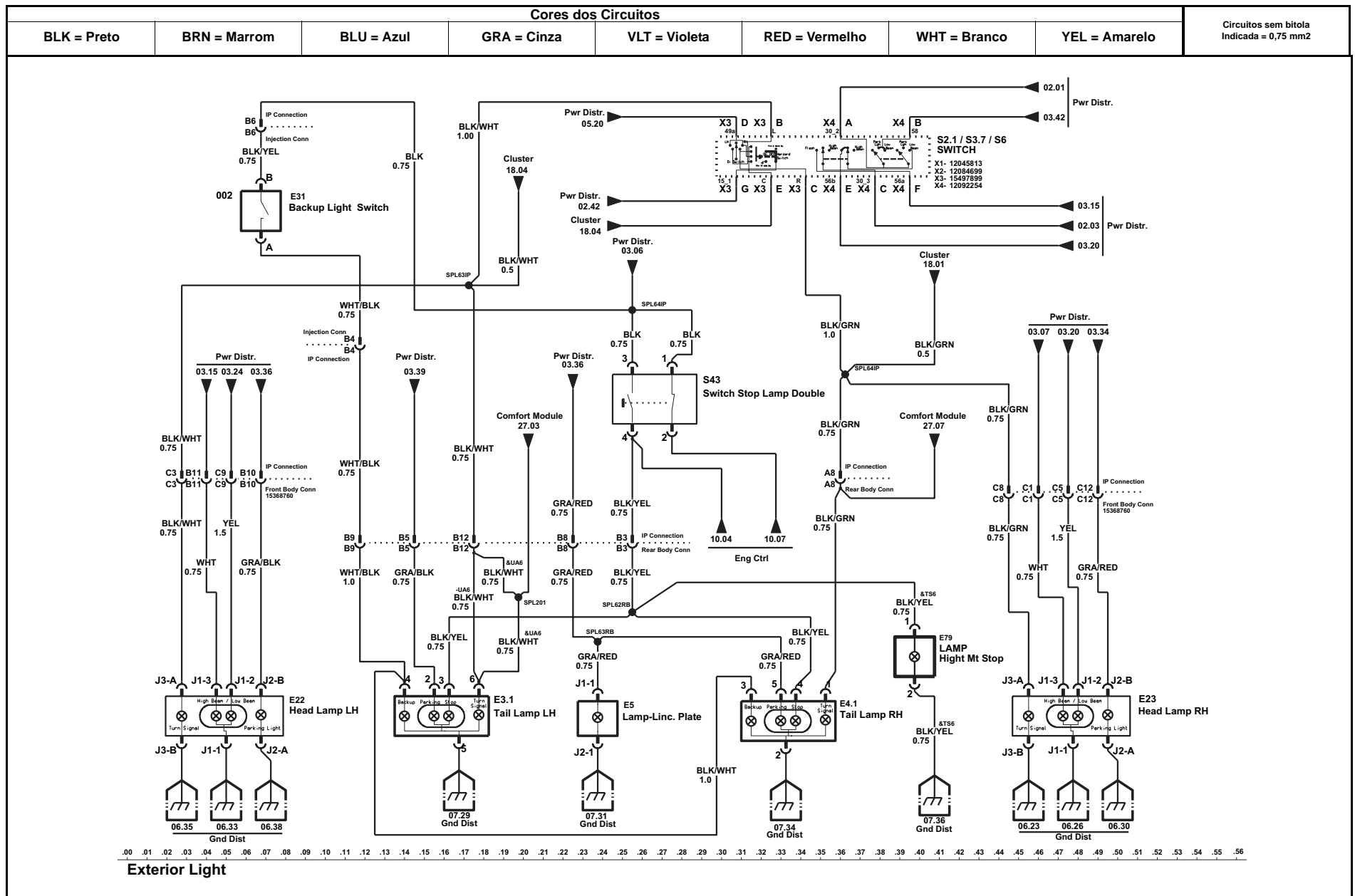

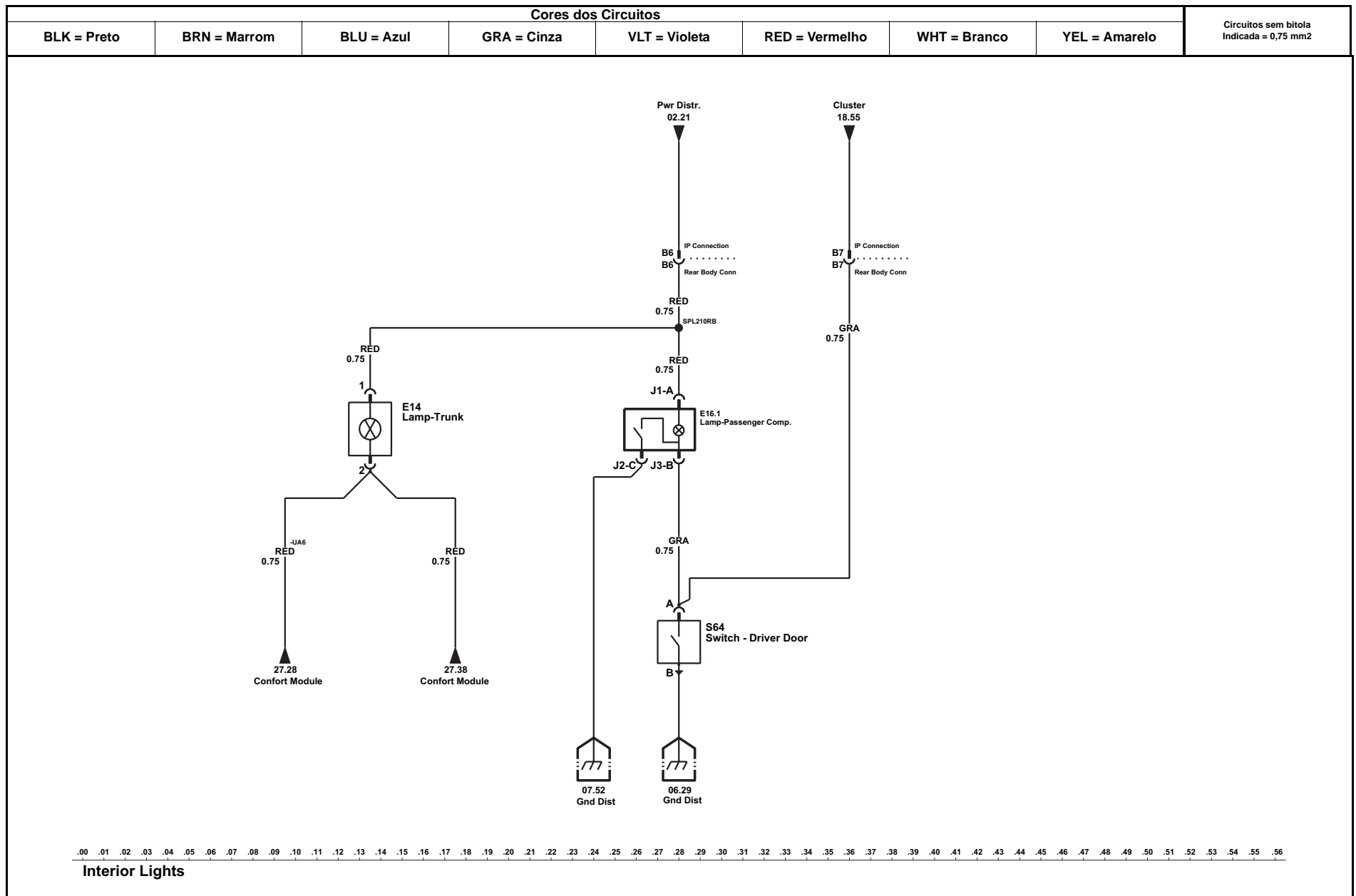

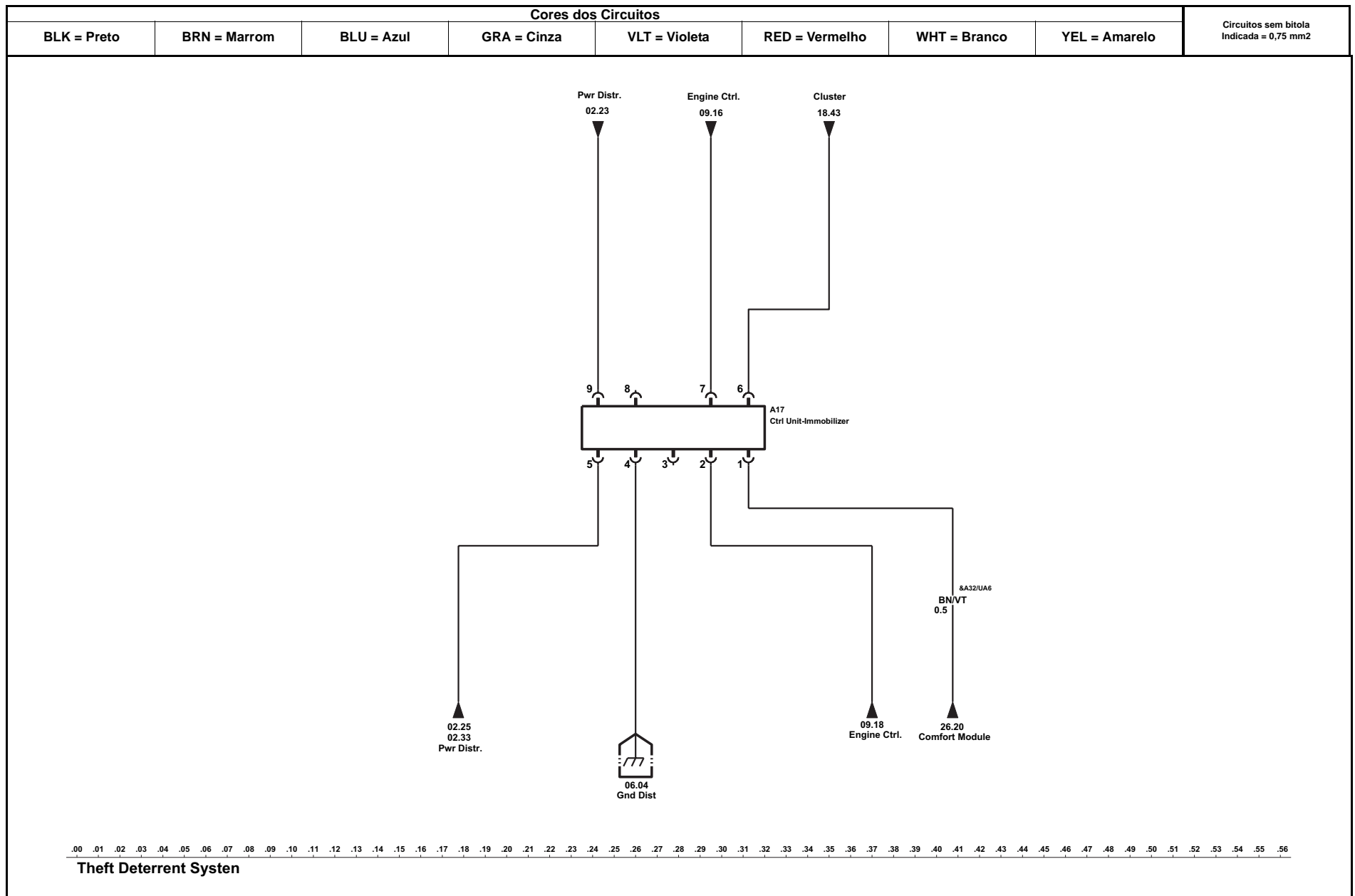

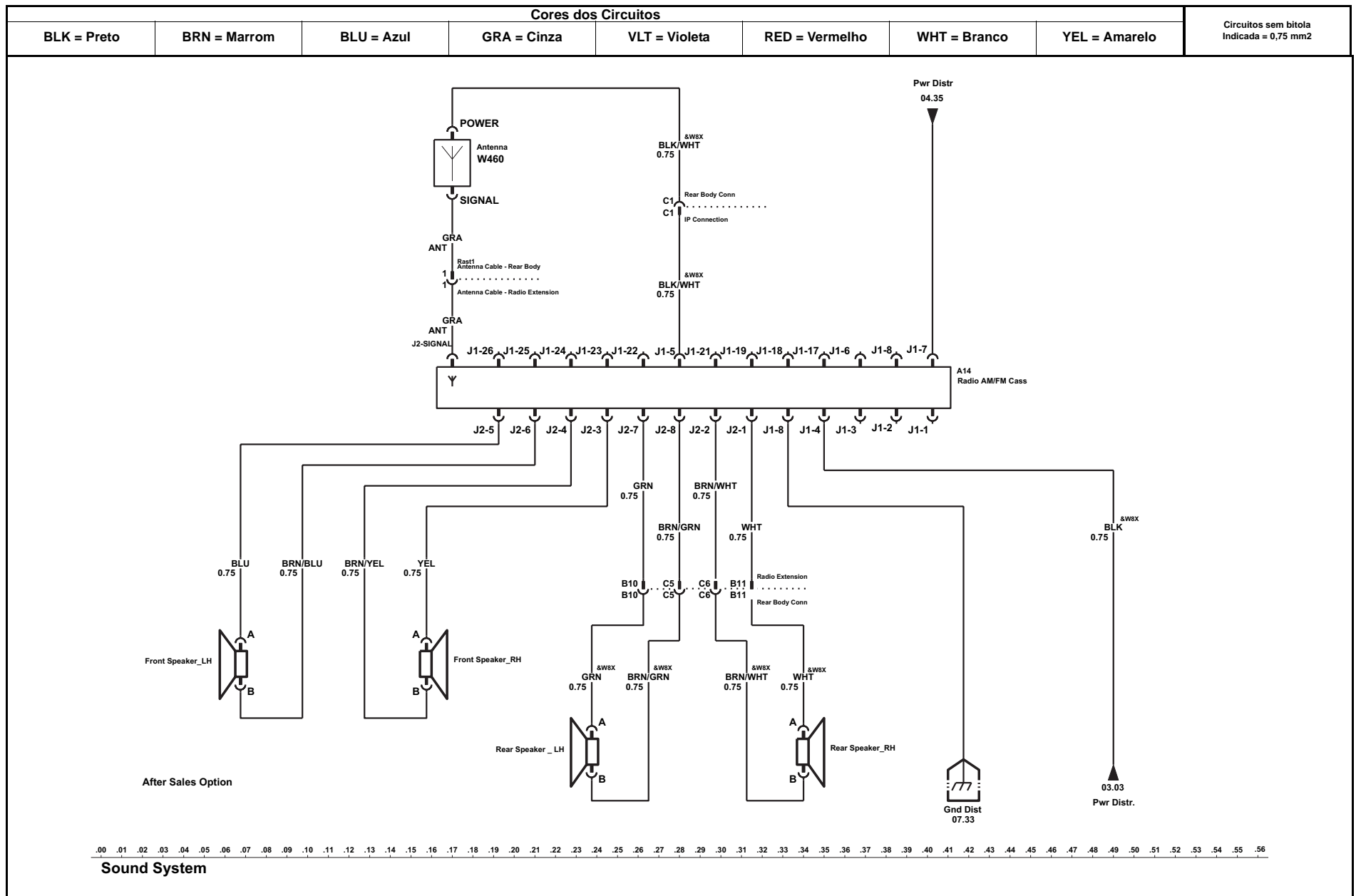

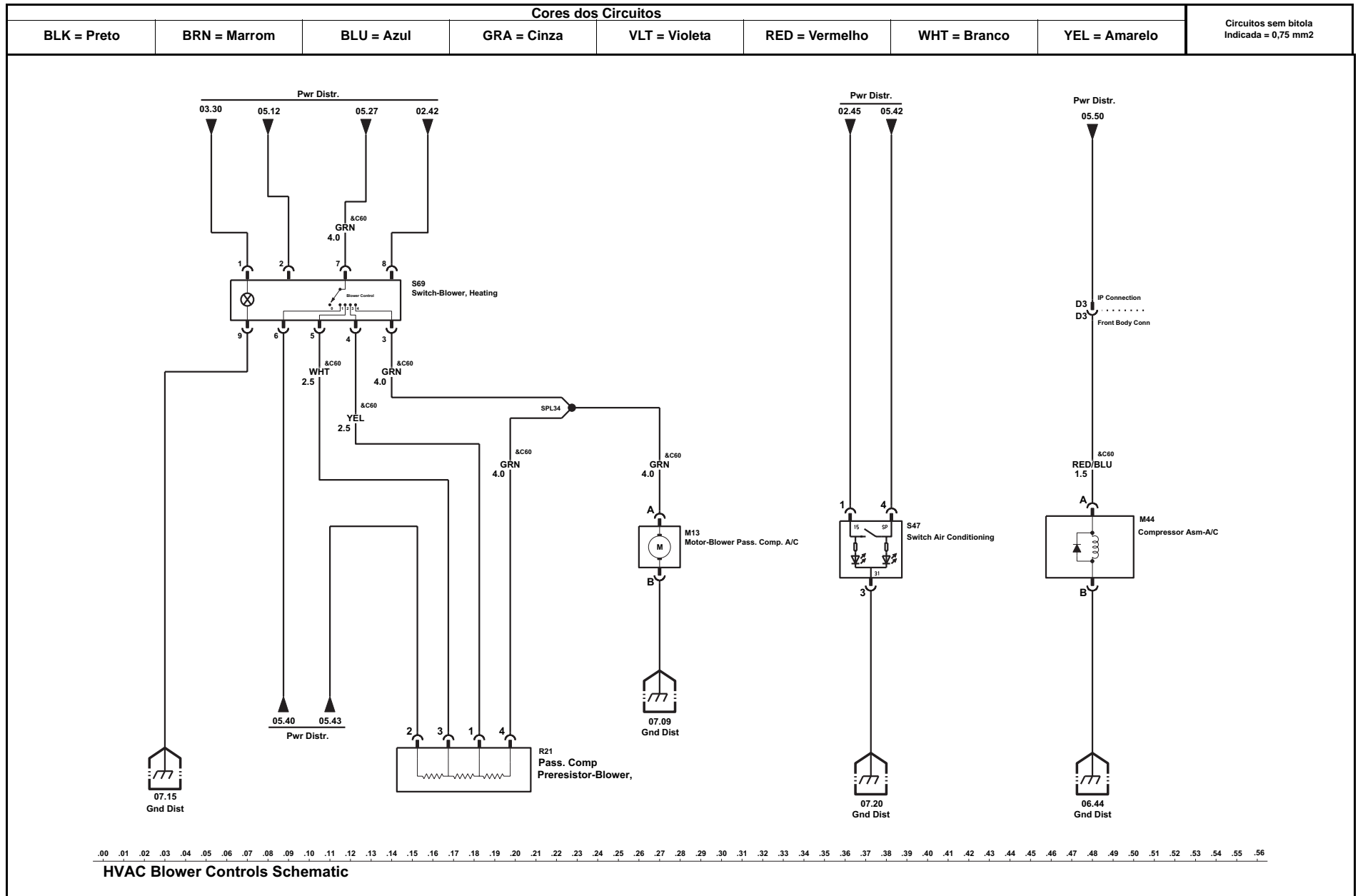

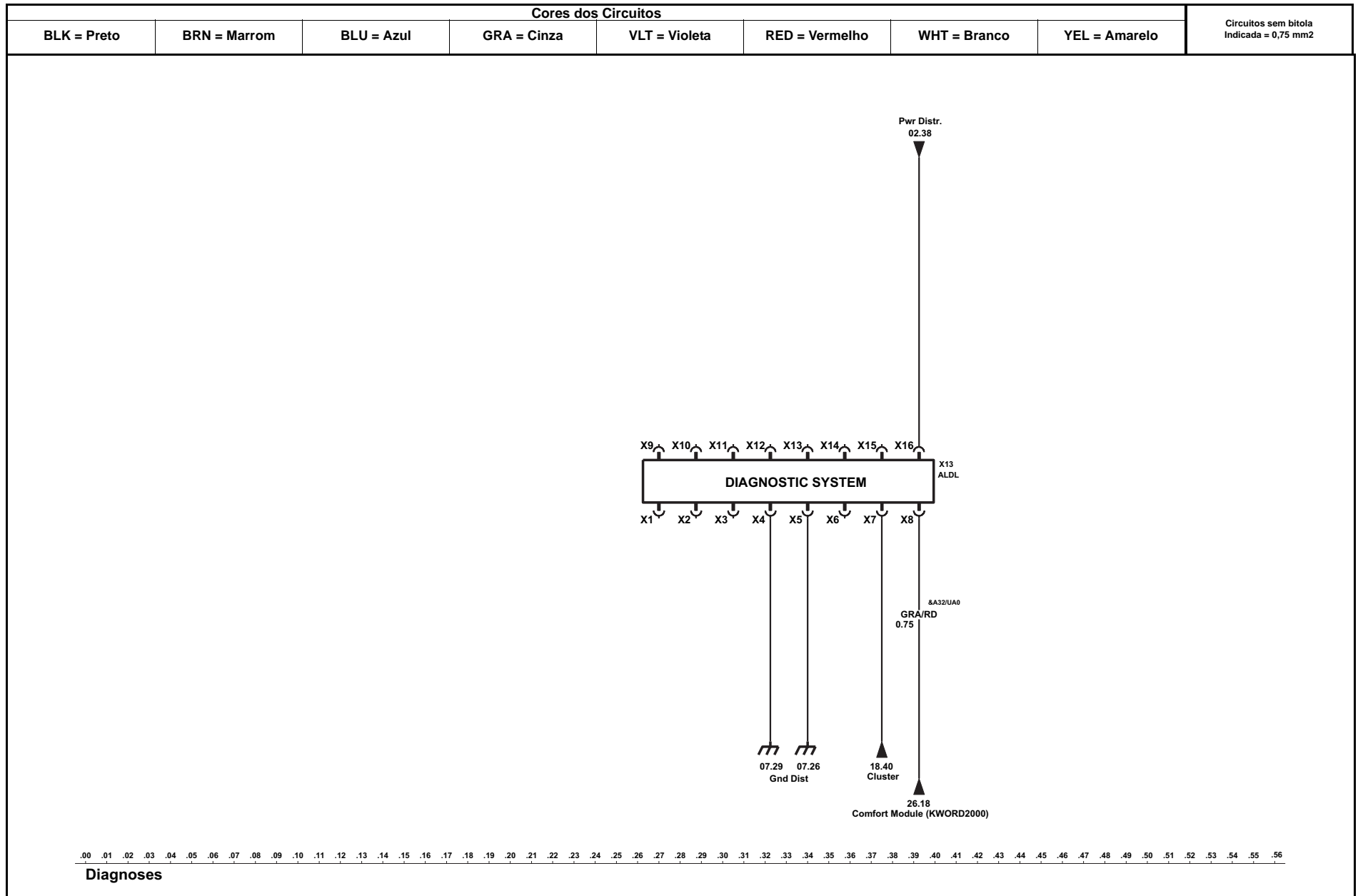

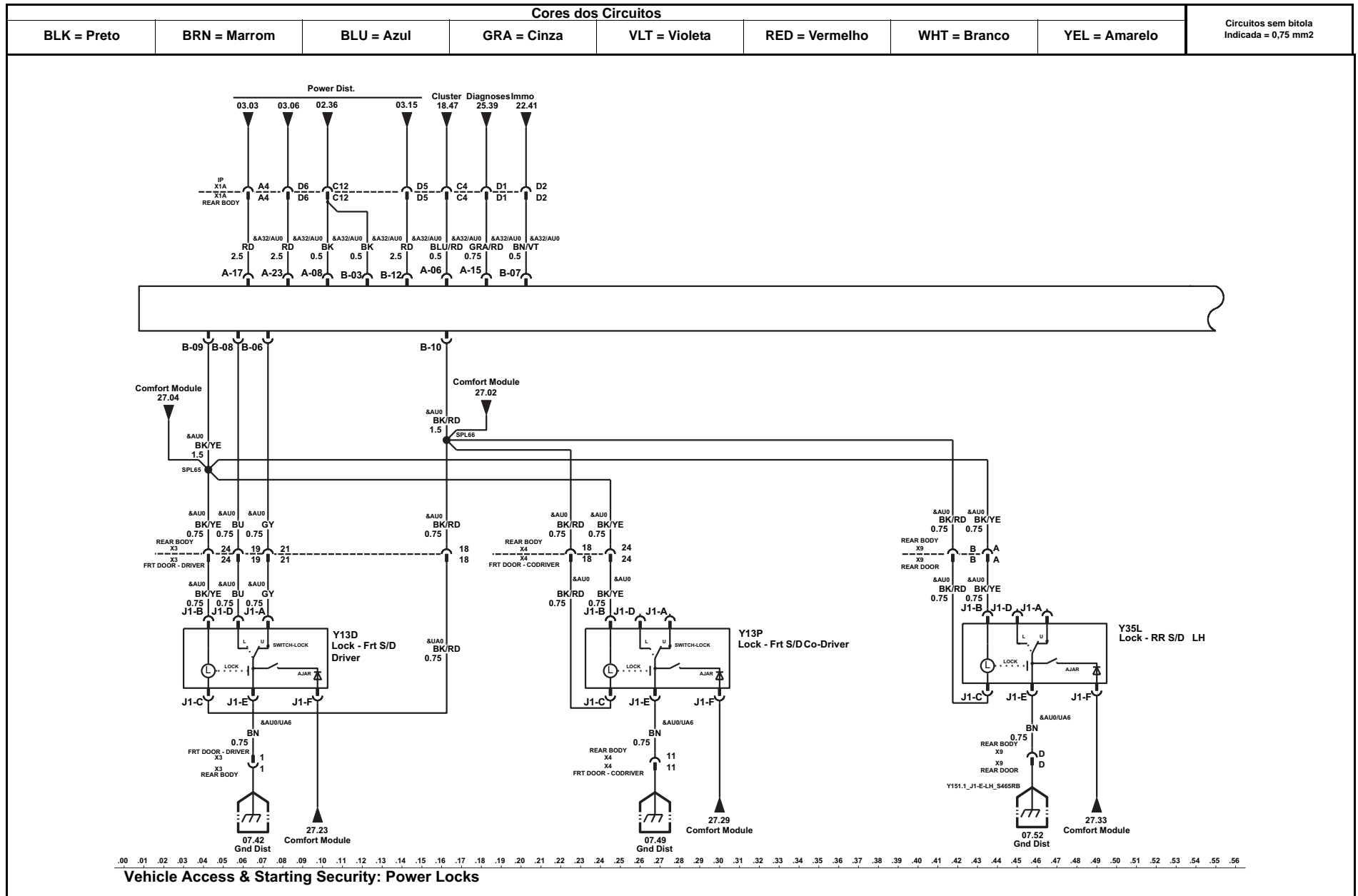

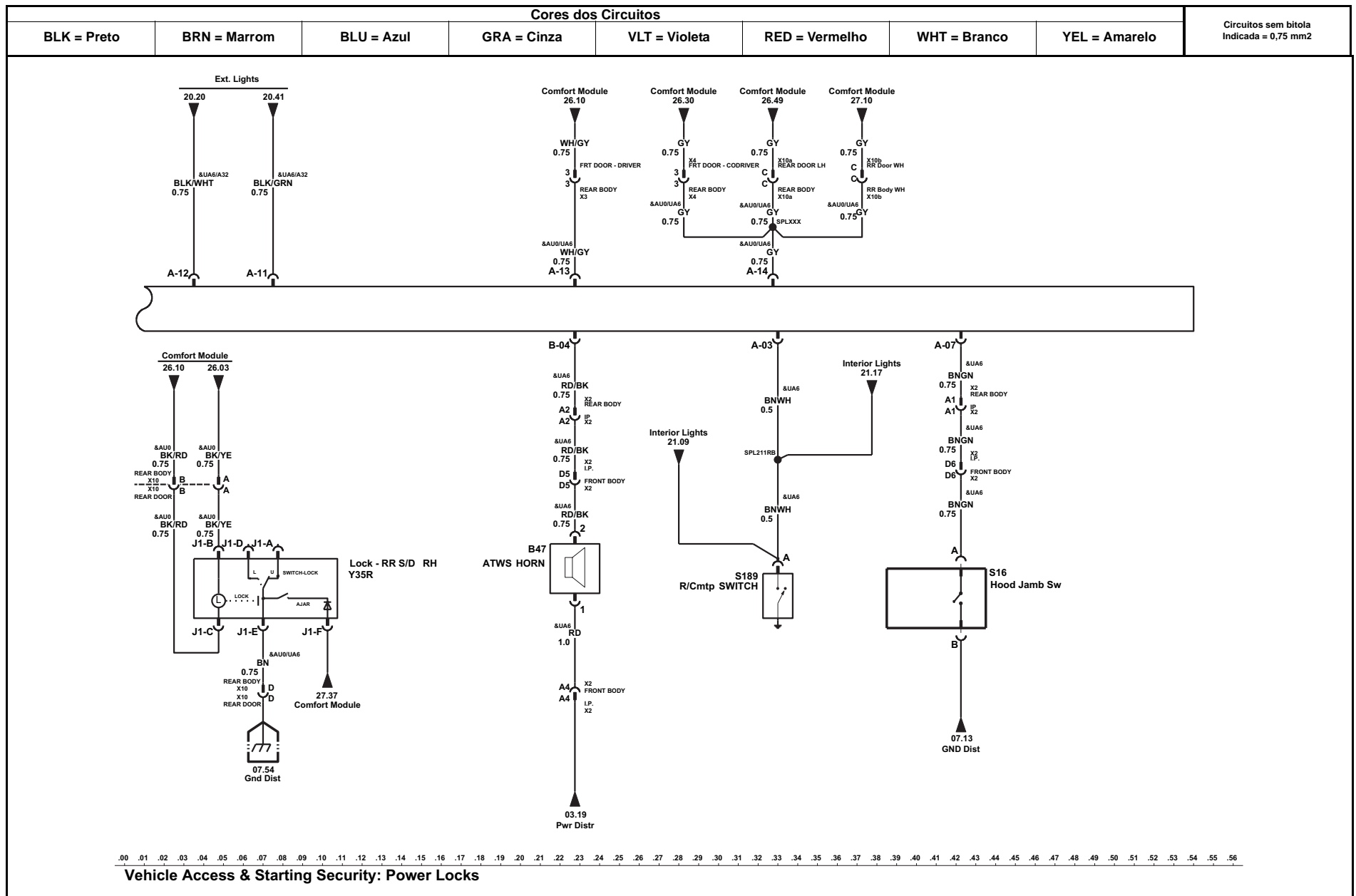

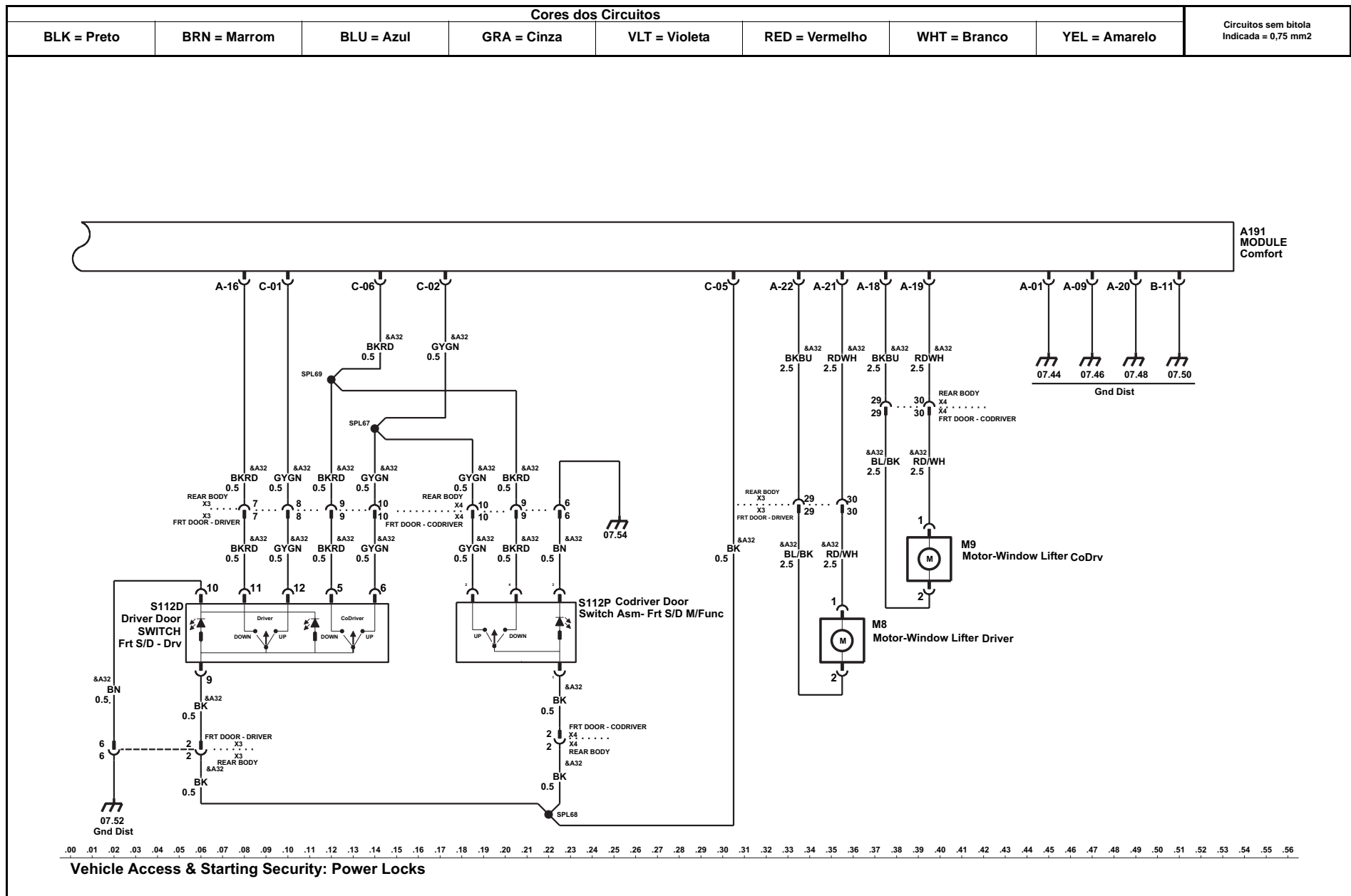

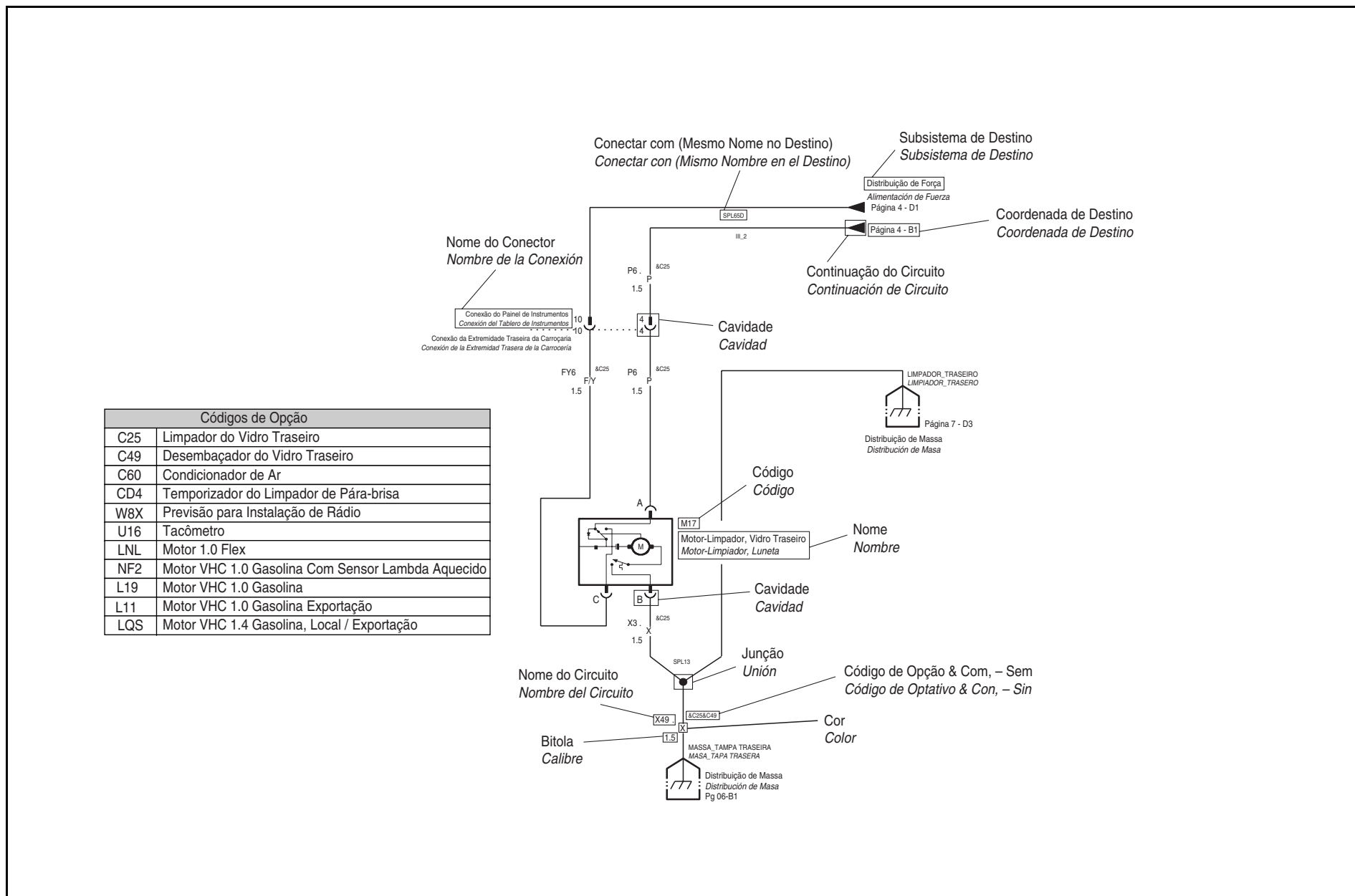

Códigos de Opção	
C25	Limpador do Vidro Traseiro
C49	Desembaçador do Vidro Traseiro
C60	Condicionador de Ar
CD4	Temporizador do Limpador de Pára-brisa
W8X	Previsão para Instalação de Rádio
U16	Tacômetro
LNL	Motor 1.0 Flex
NF2	Motor VHC 1.0 Gasolina Com Sensor Lambda Aquecido
L19	Motor VHC 1.0 Gasolina
L11	Motor VHC 1.0 Gasolina Exportação
LQS	Motor VHC 1.4 Gasolina, Local / Exportação



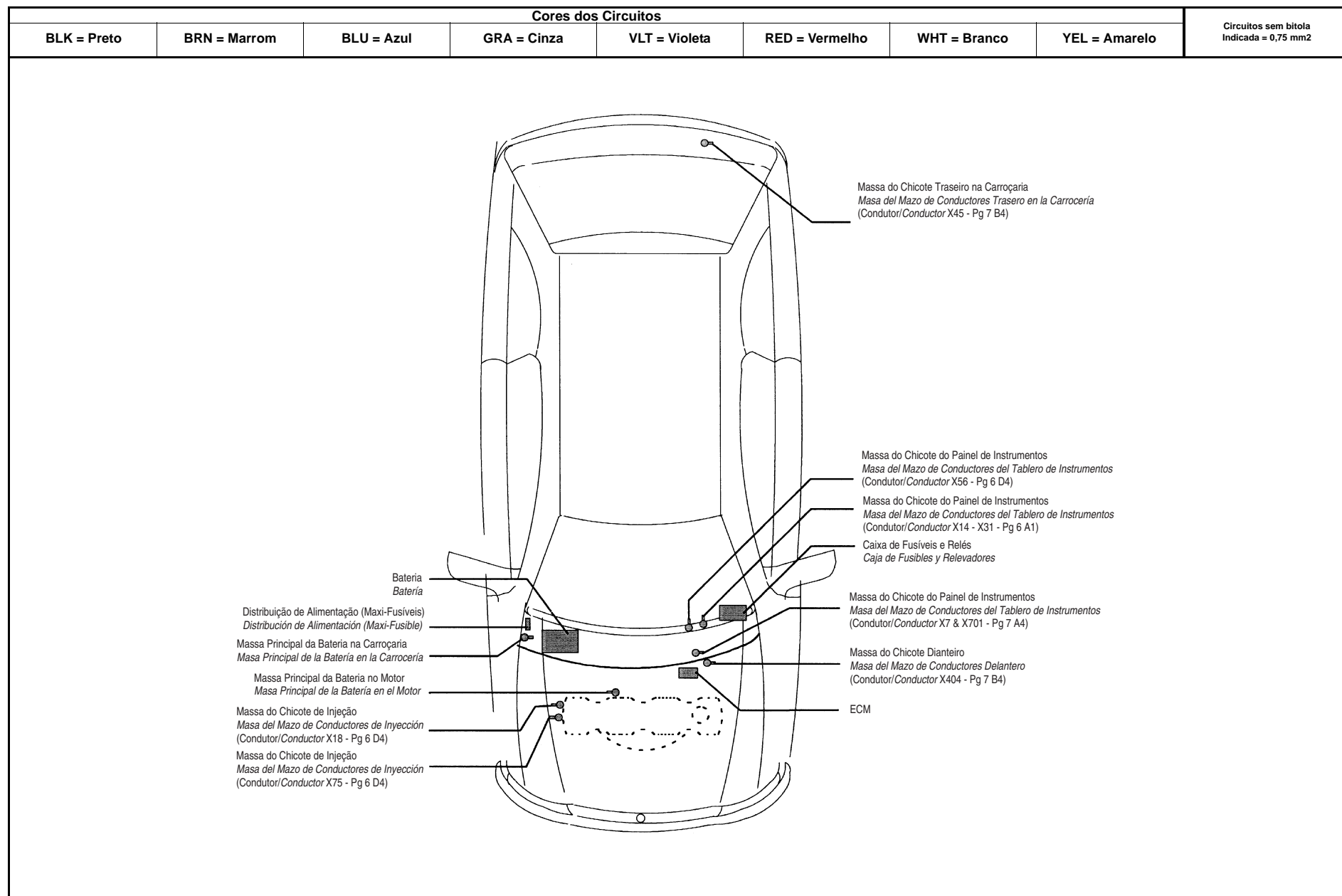

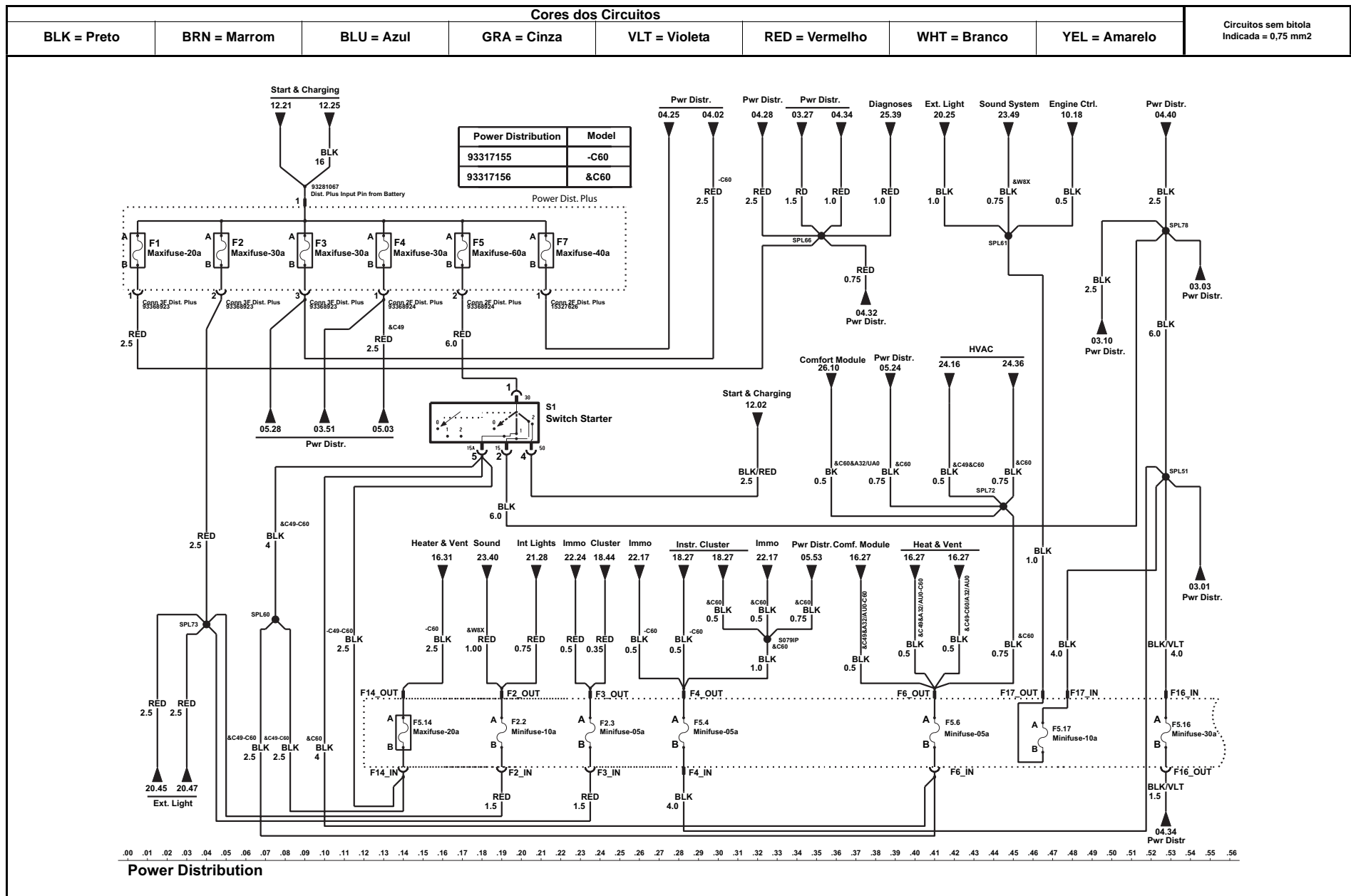

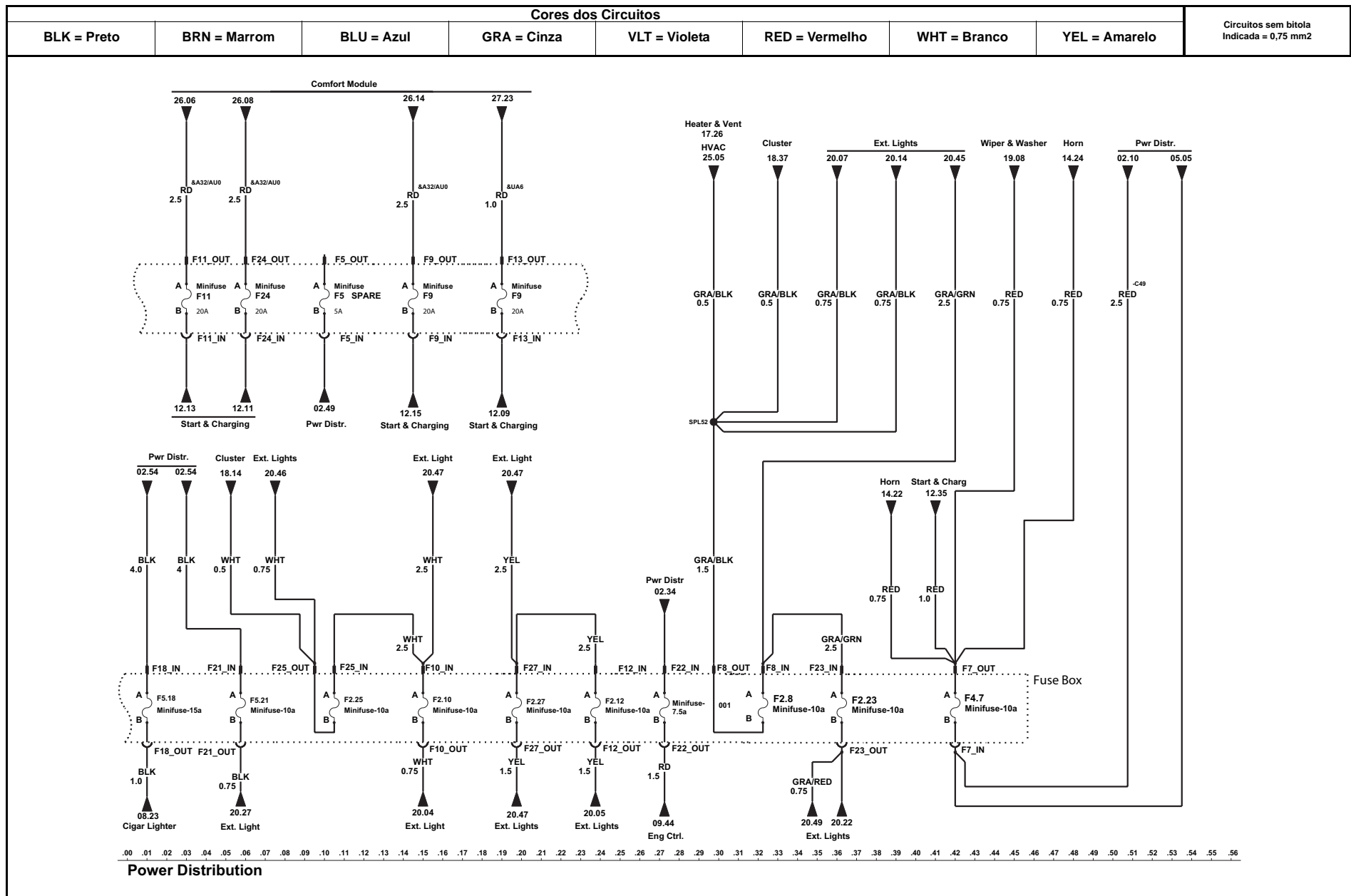

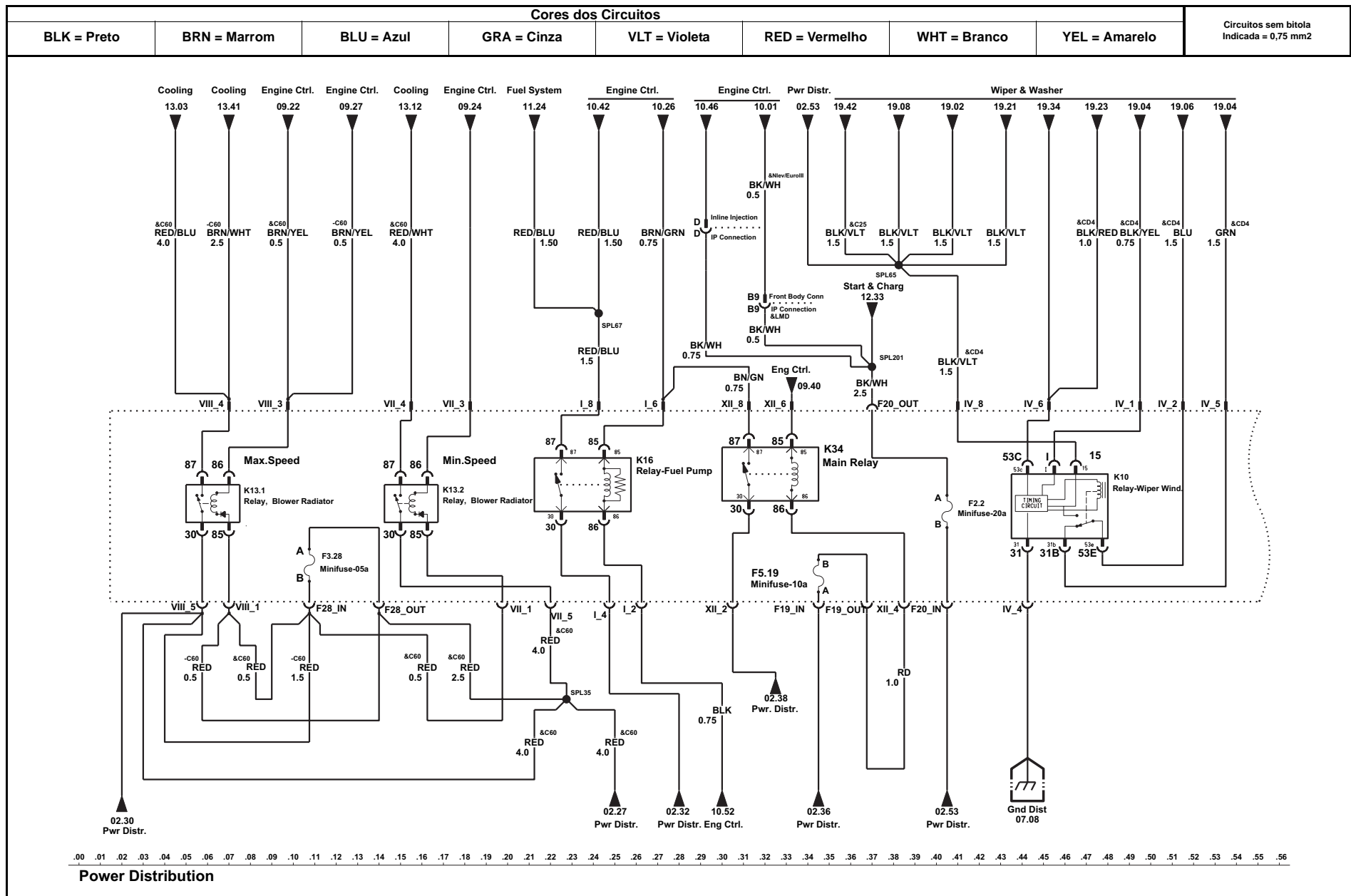

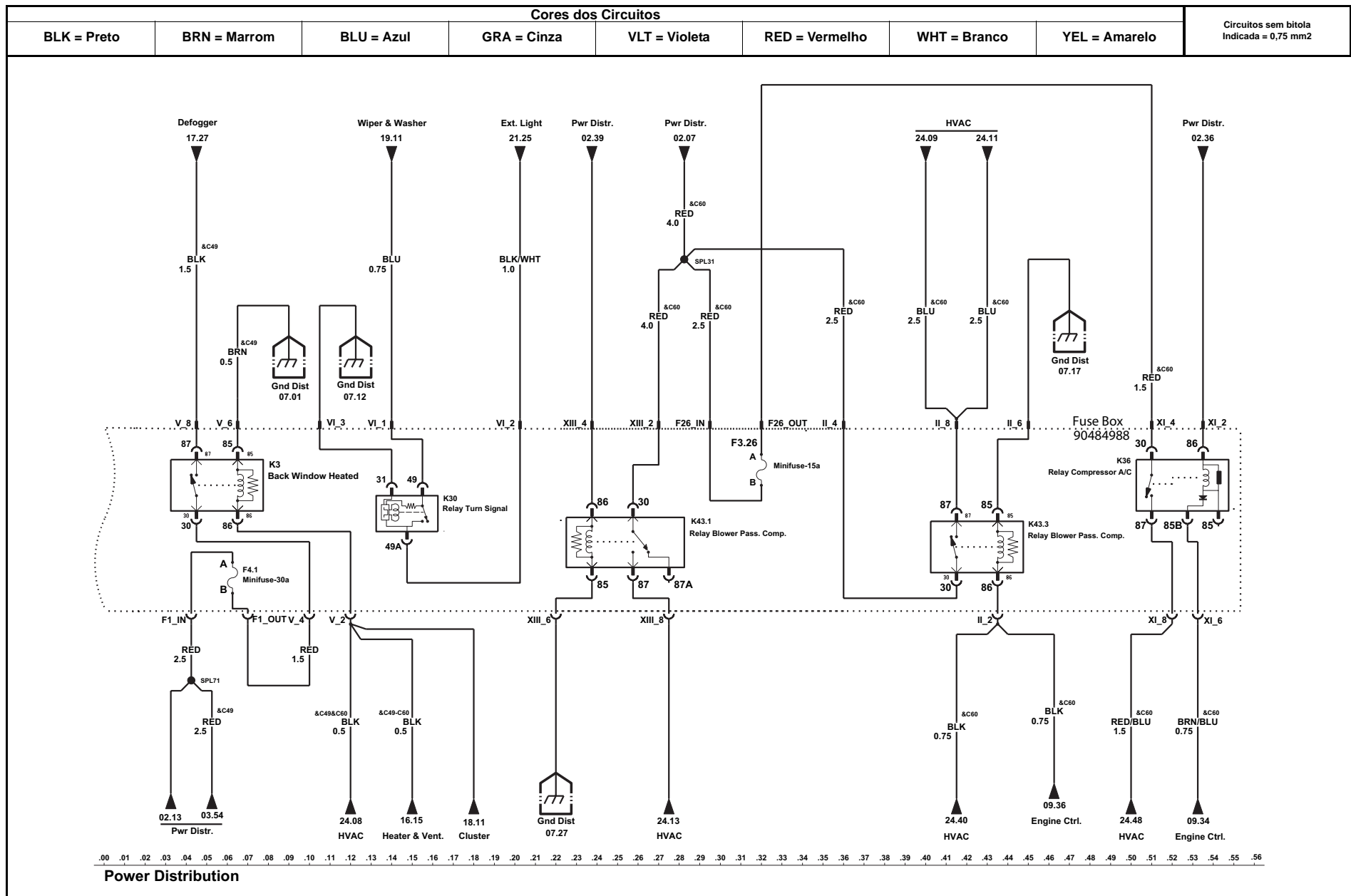

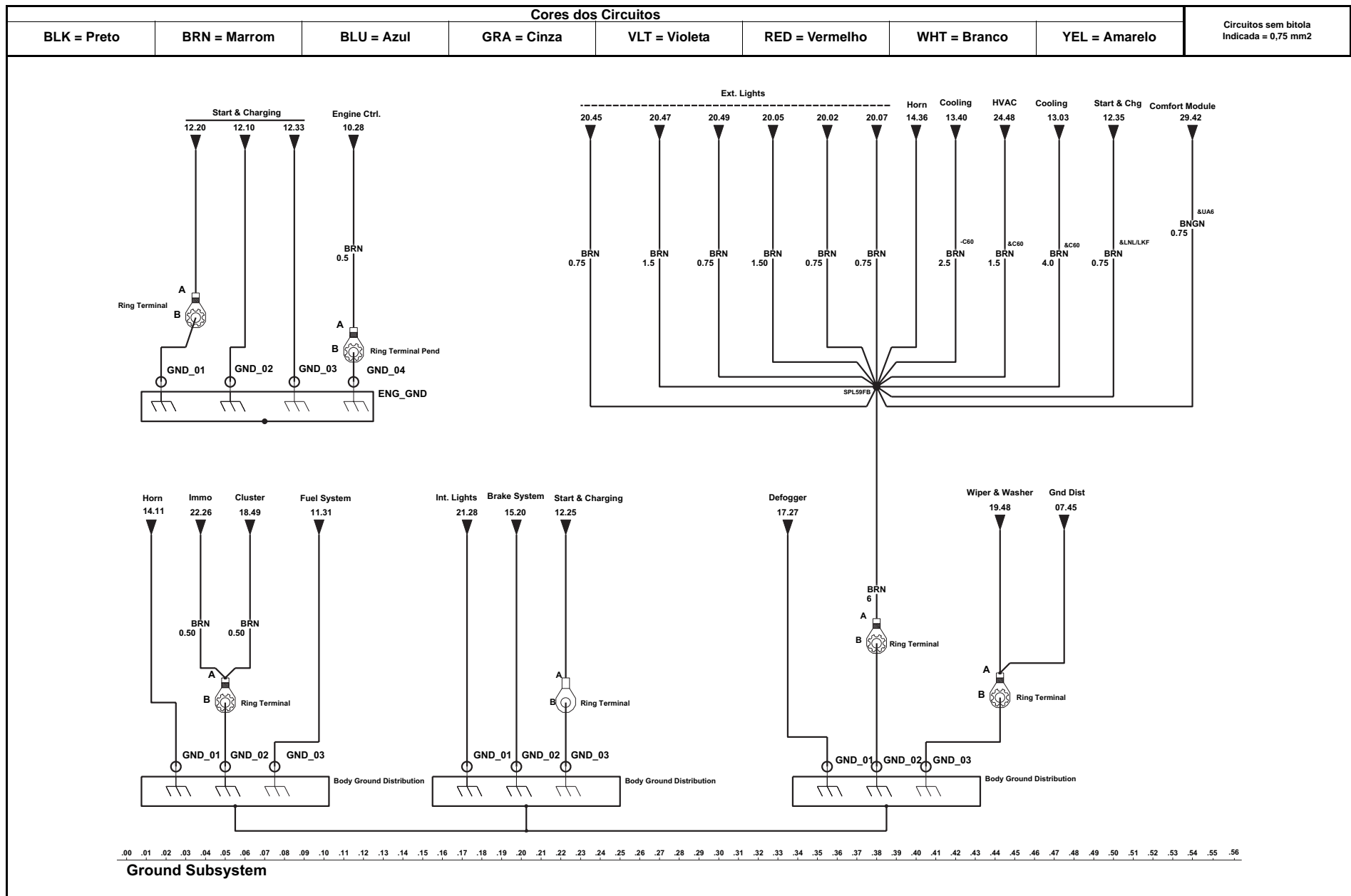

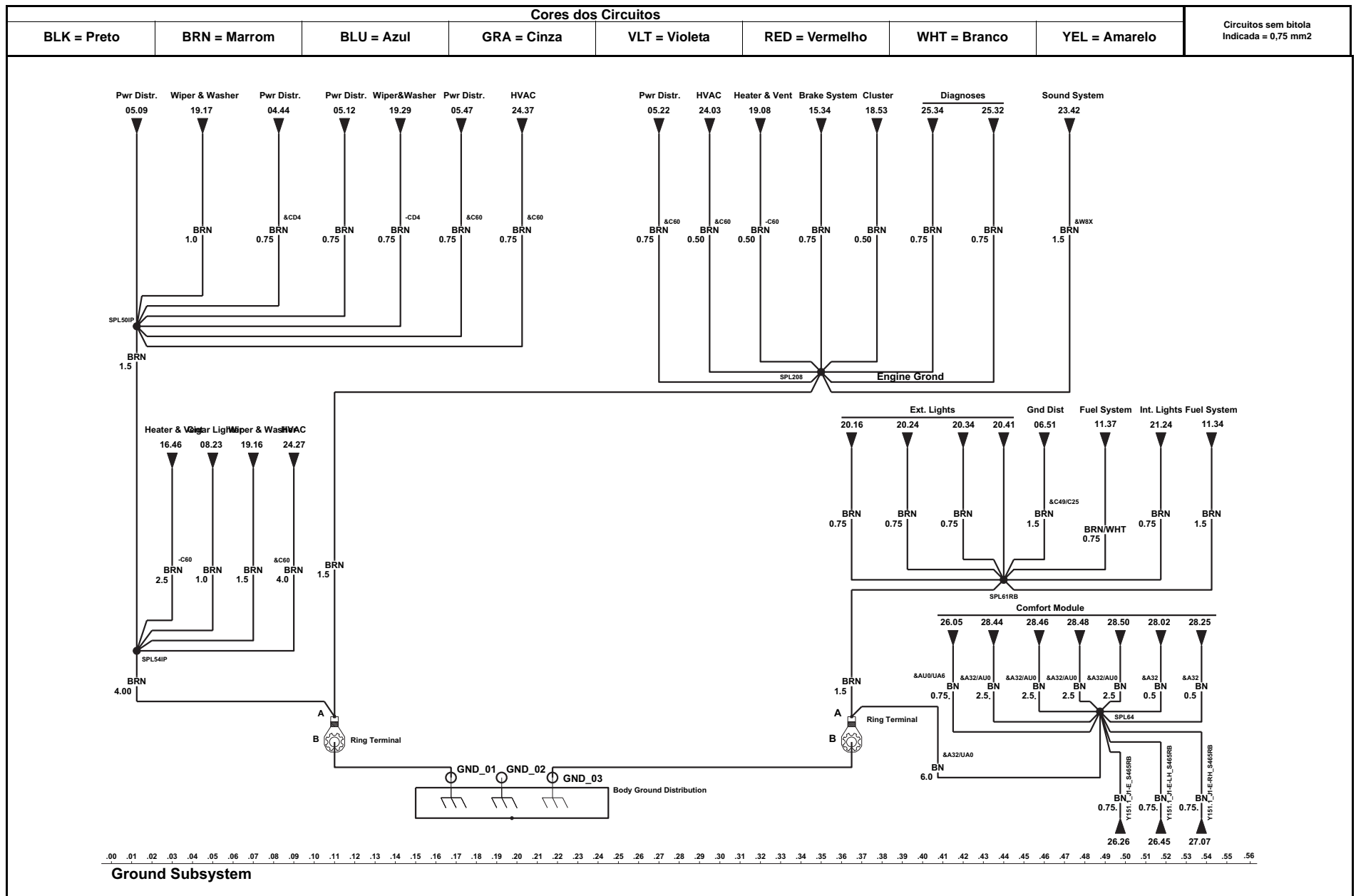

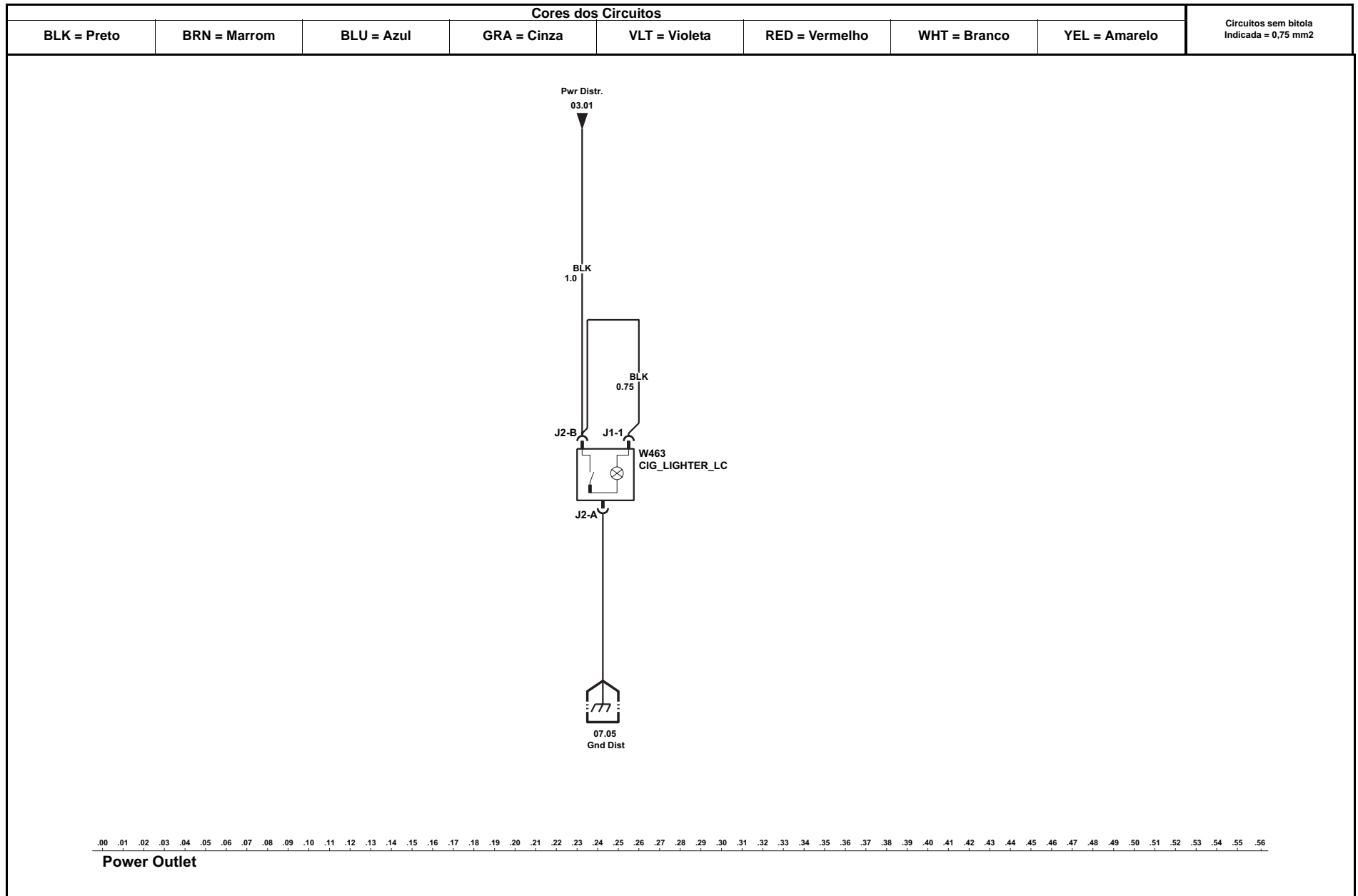

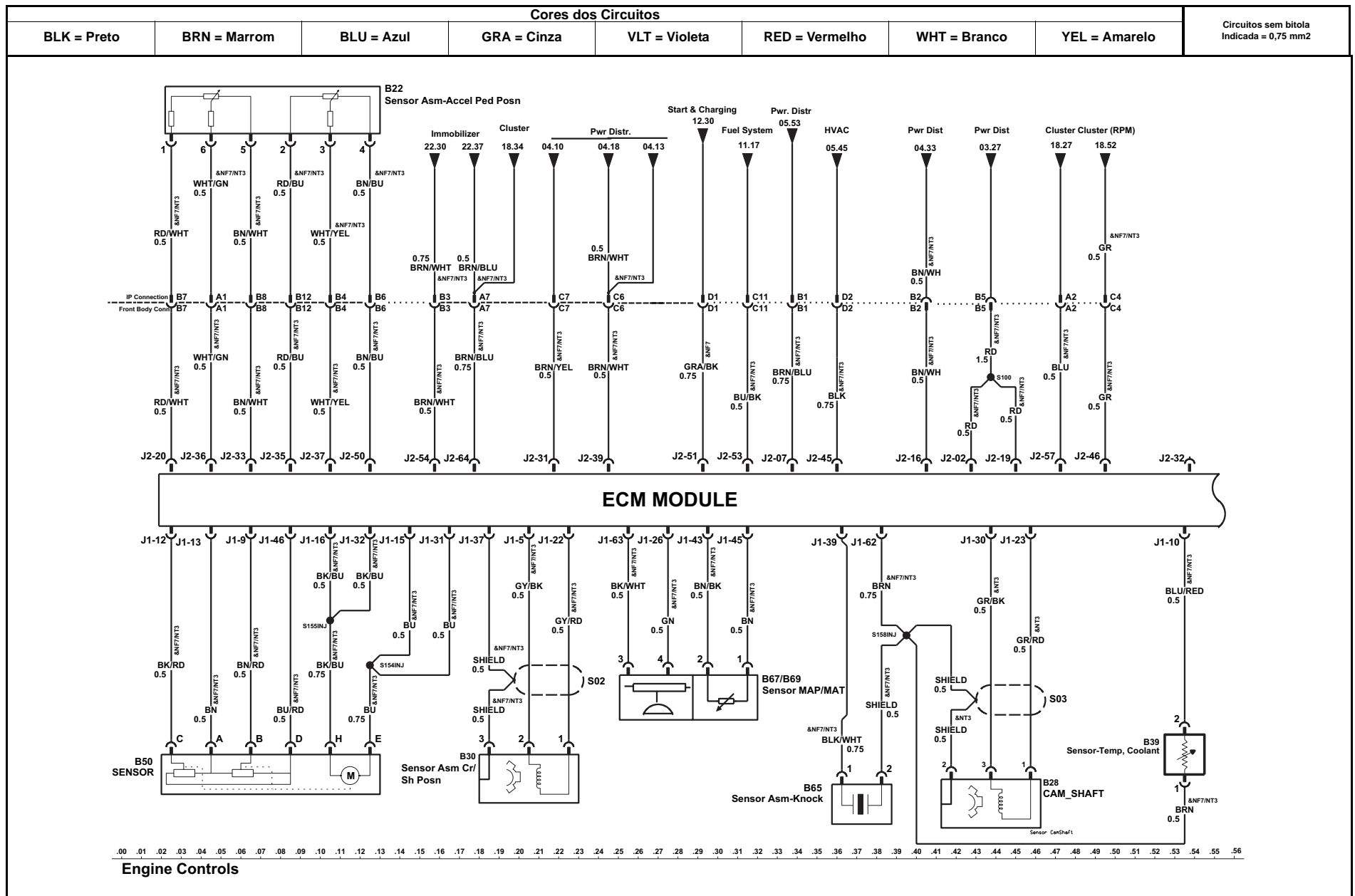

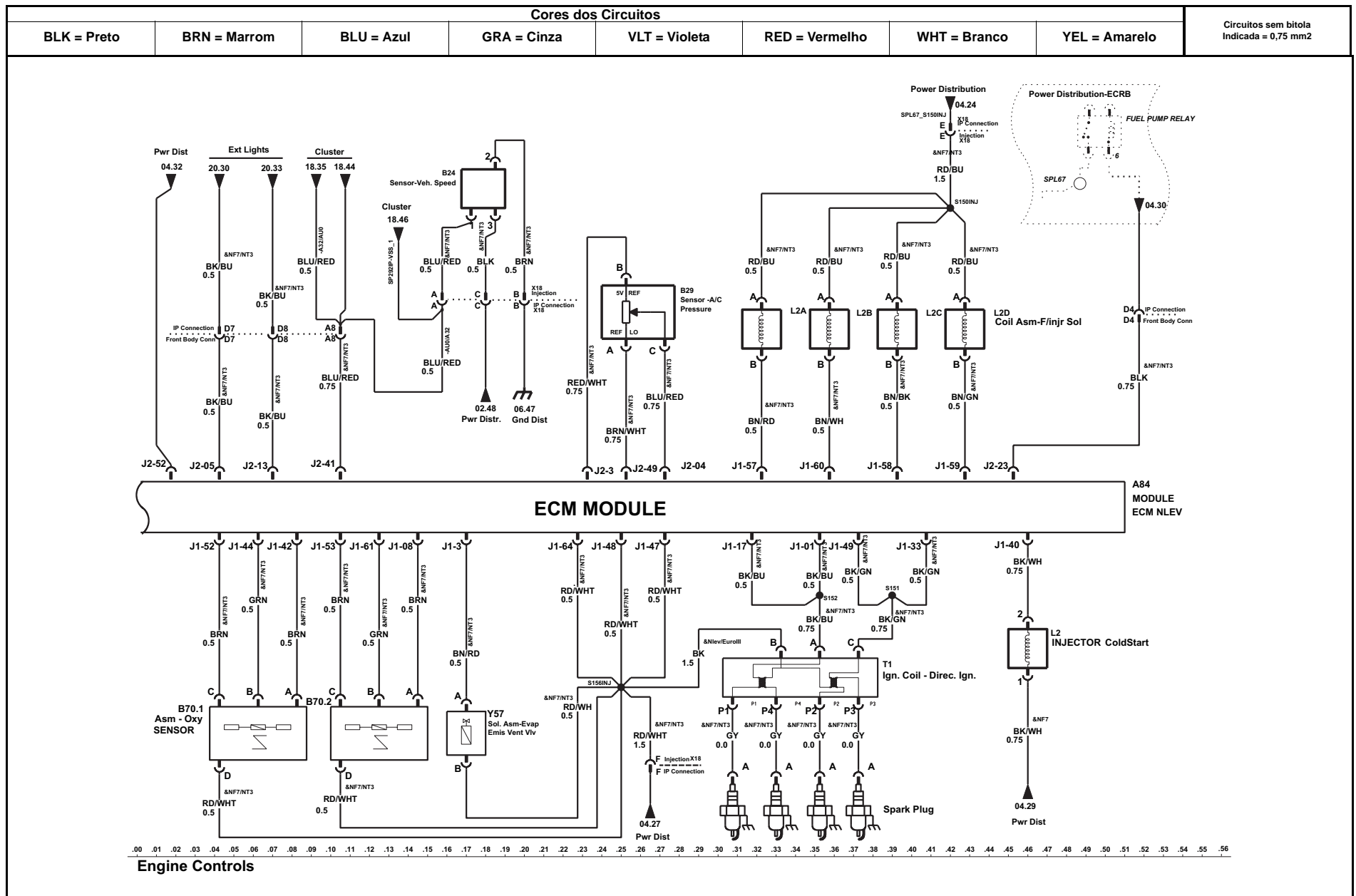

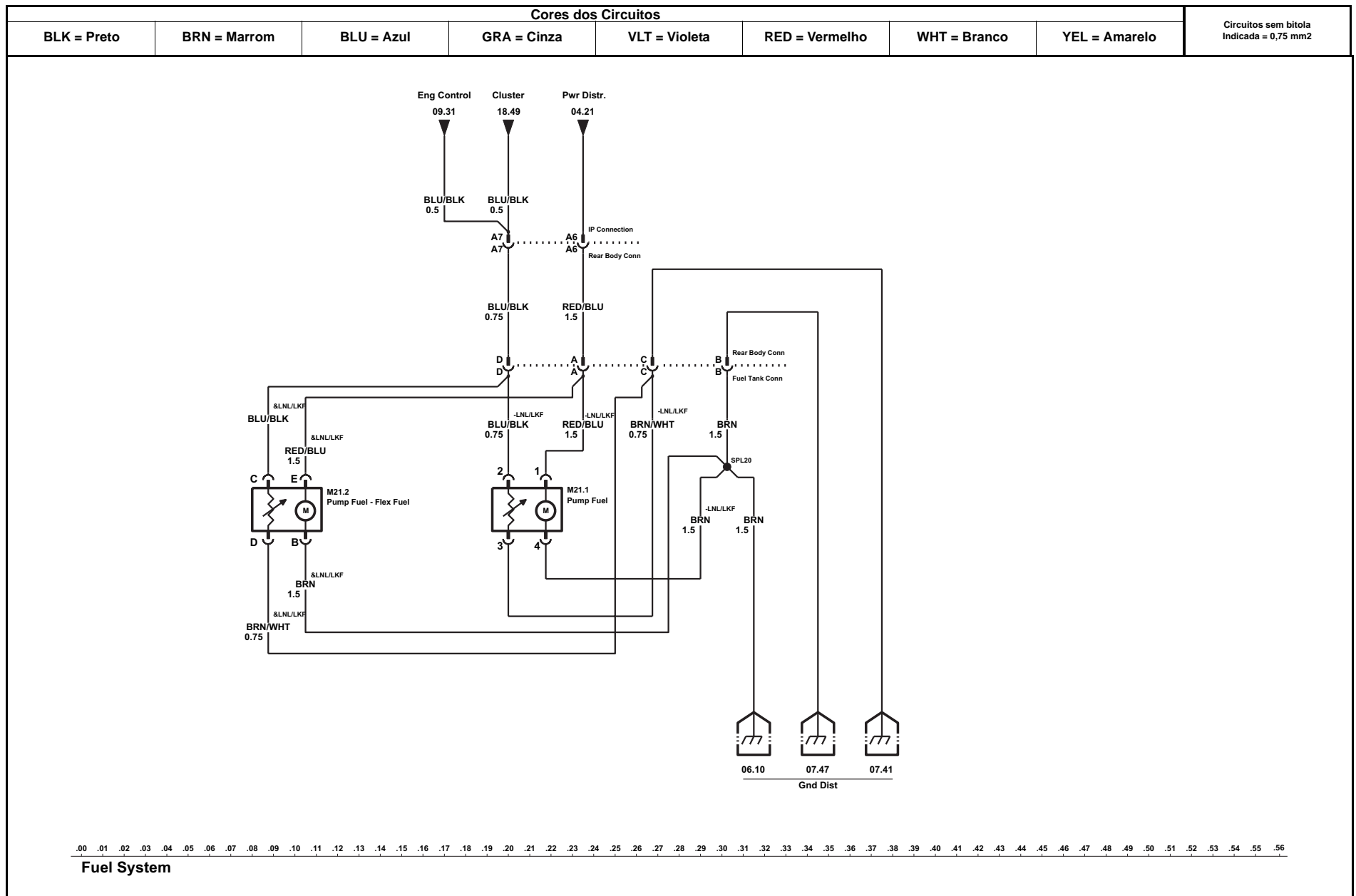

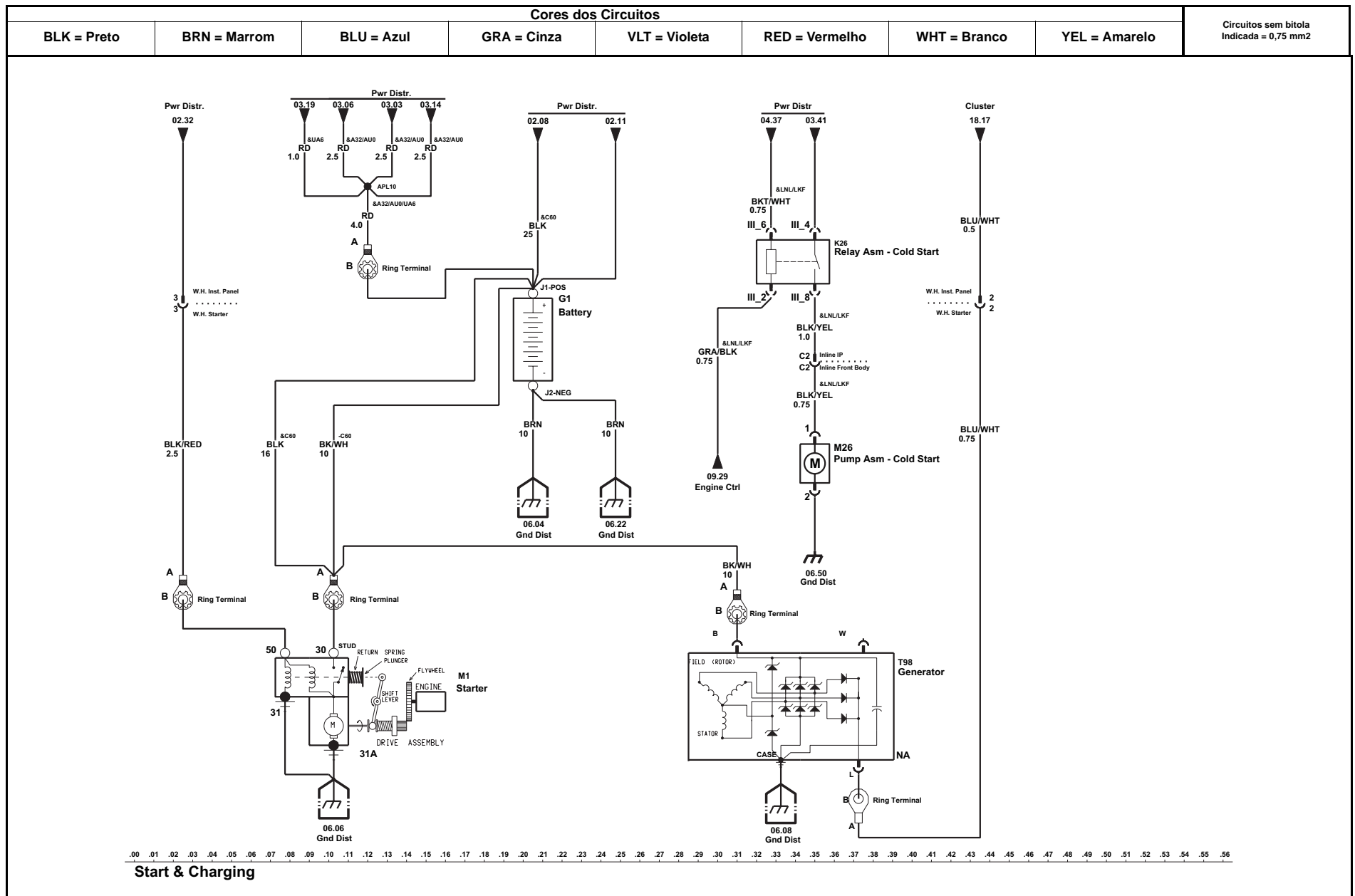

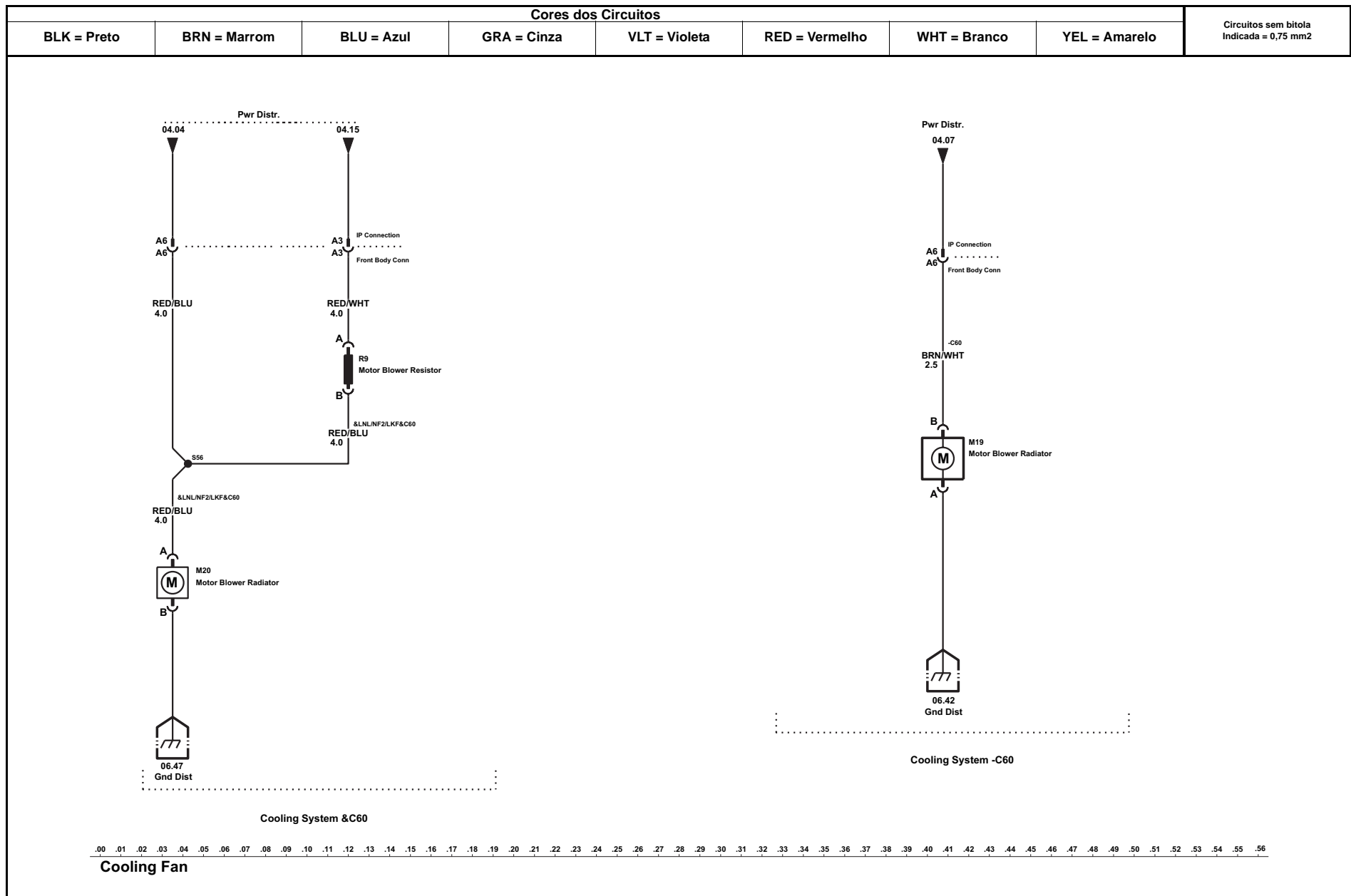

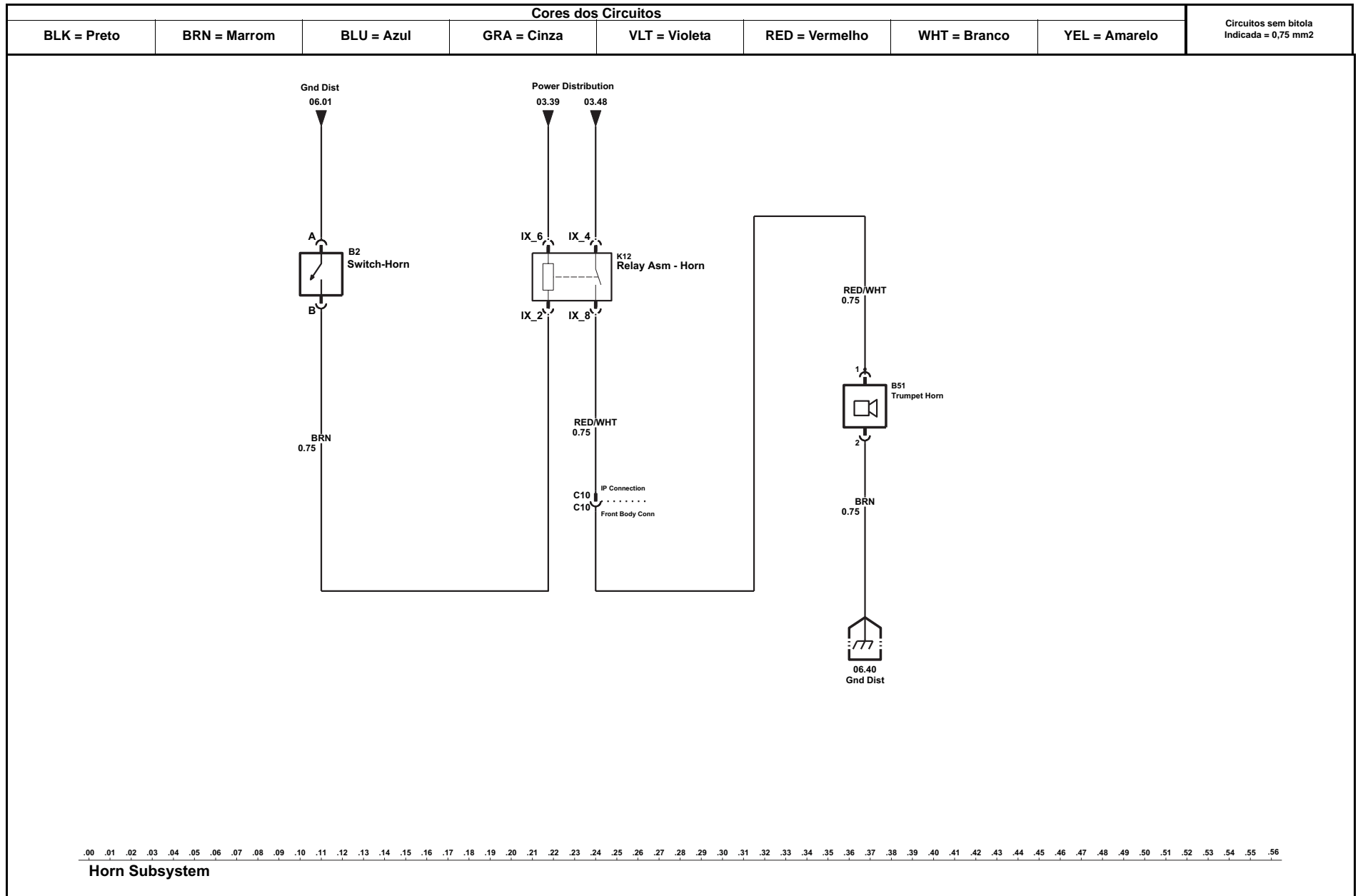

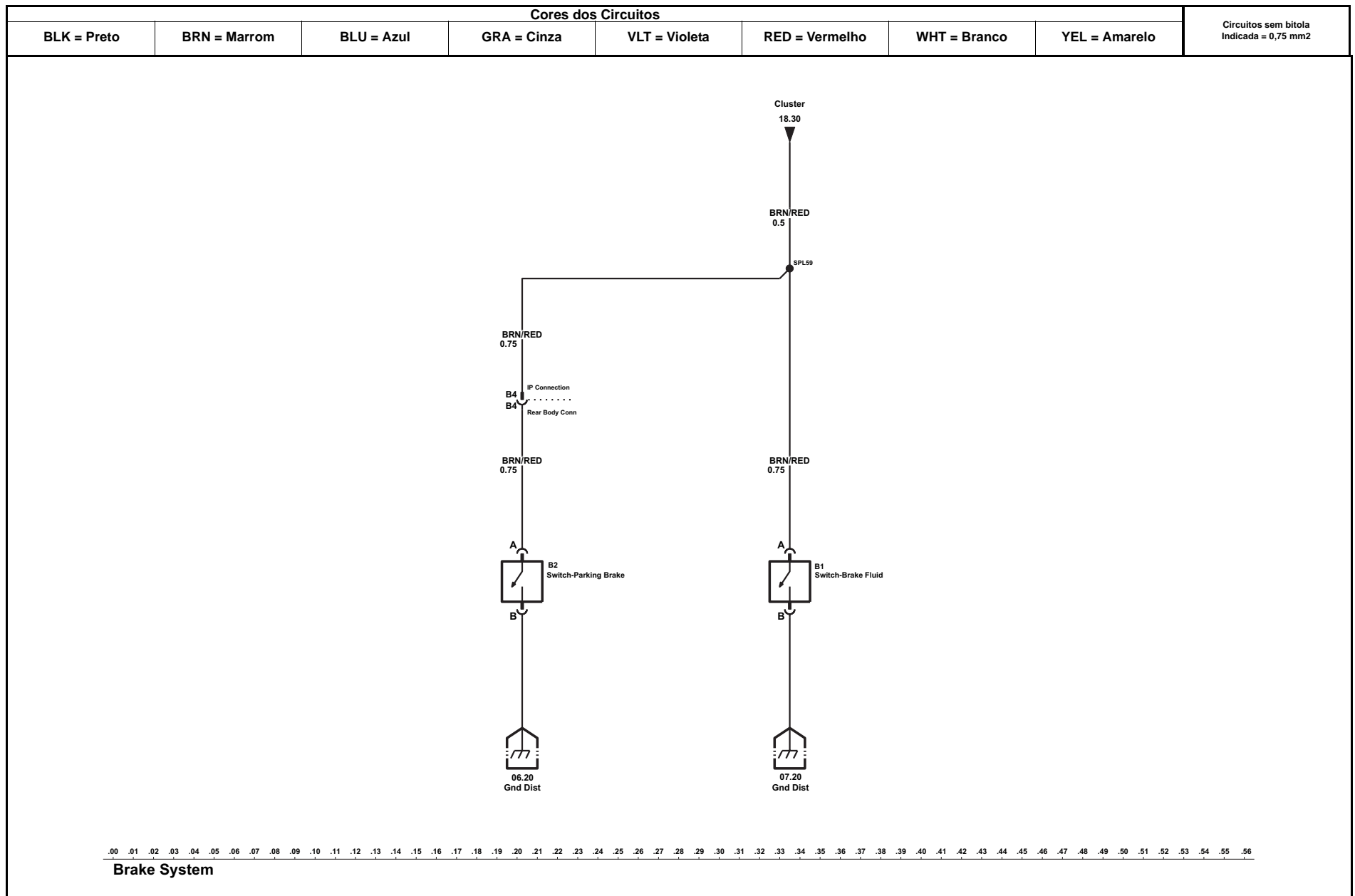

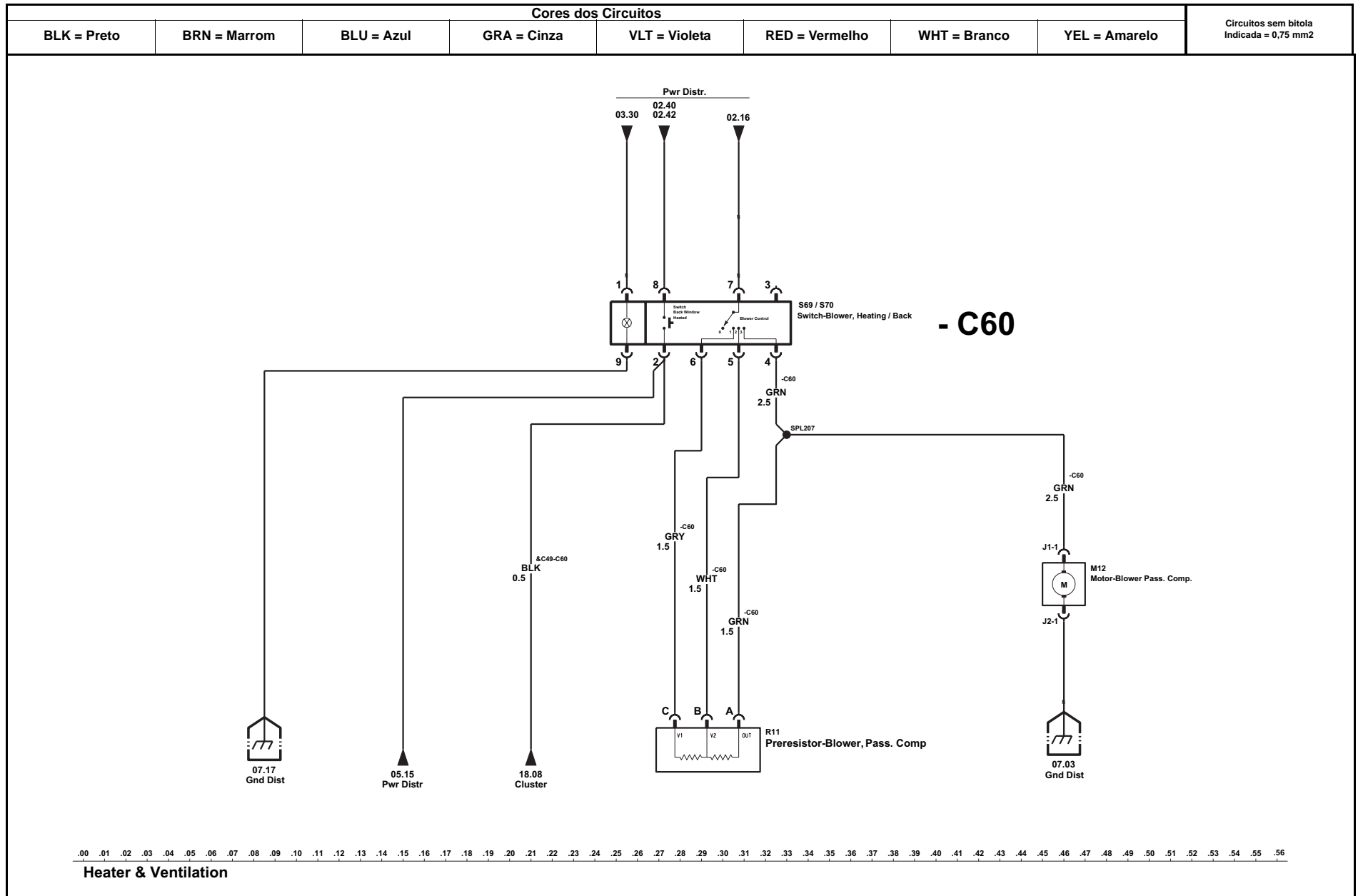

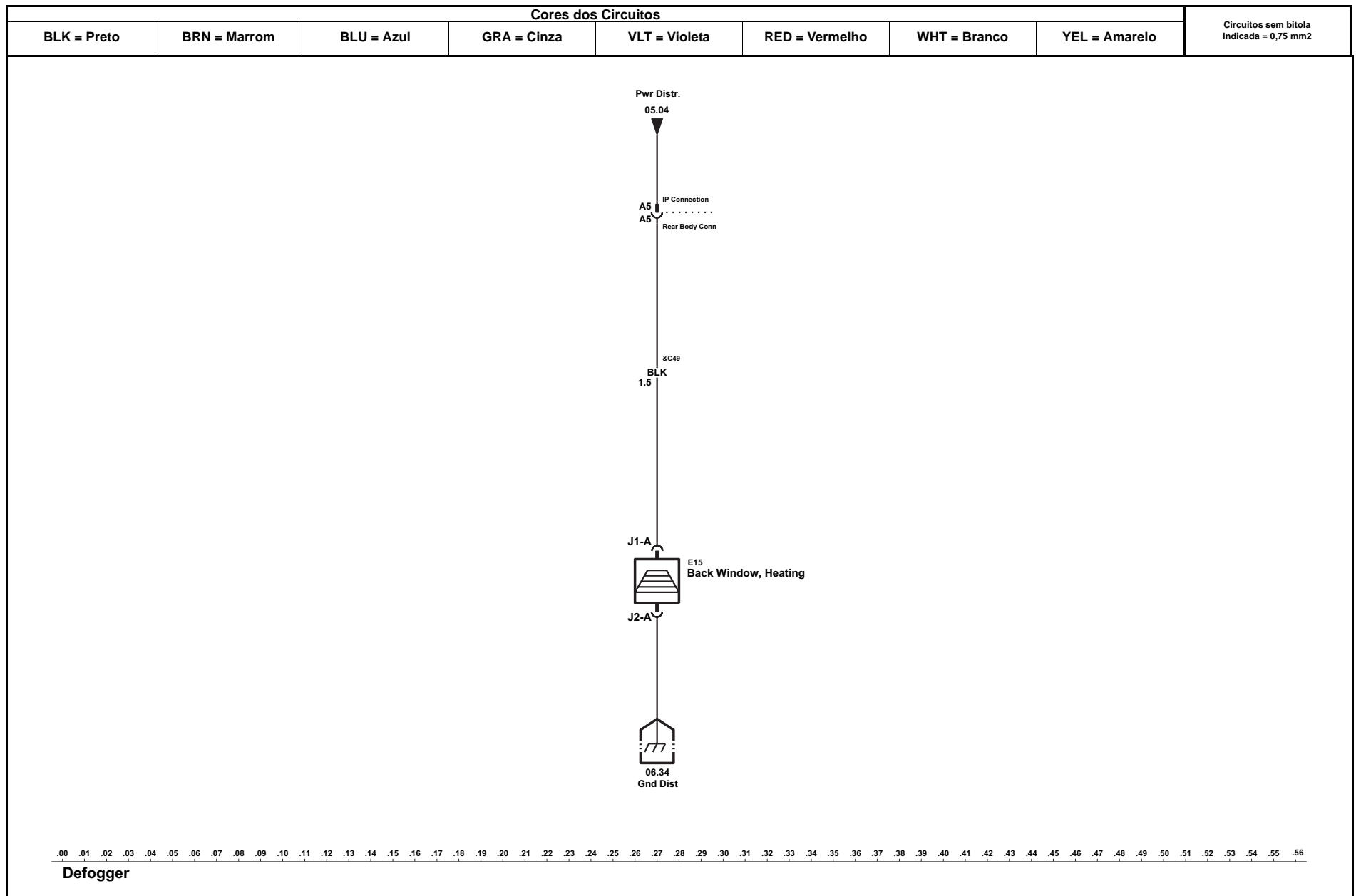

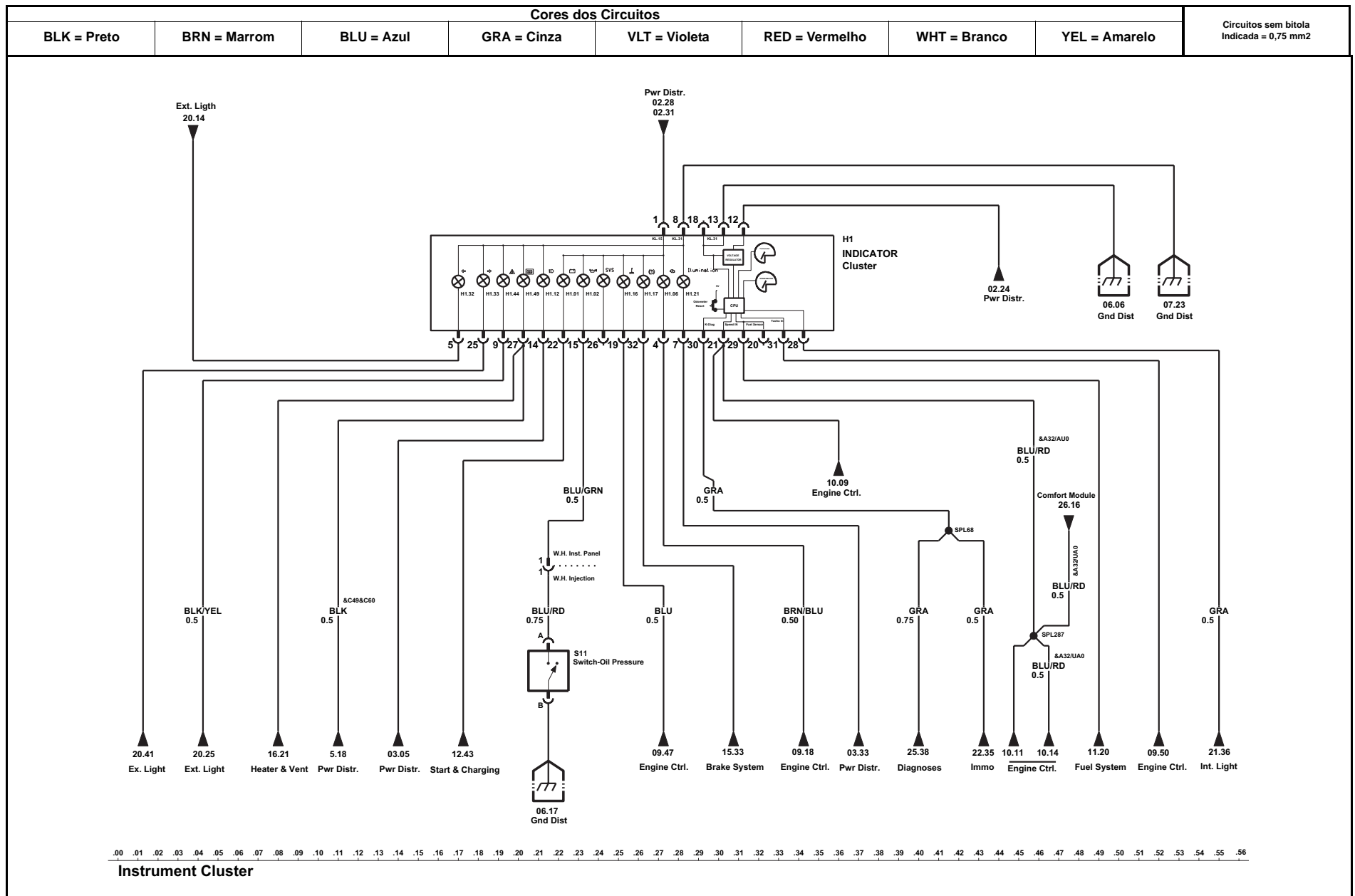

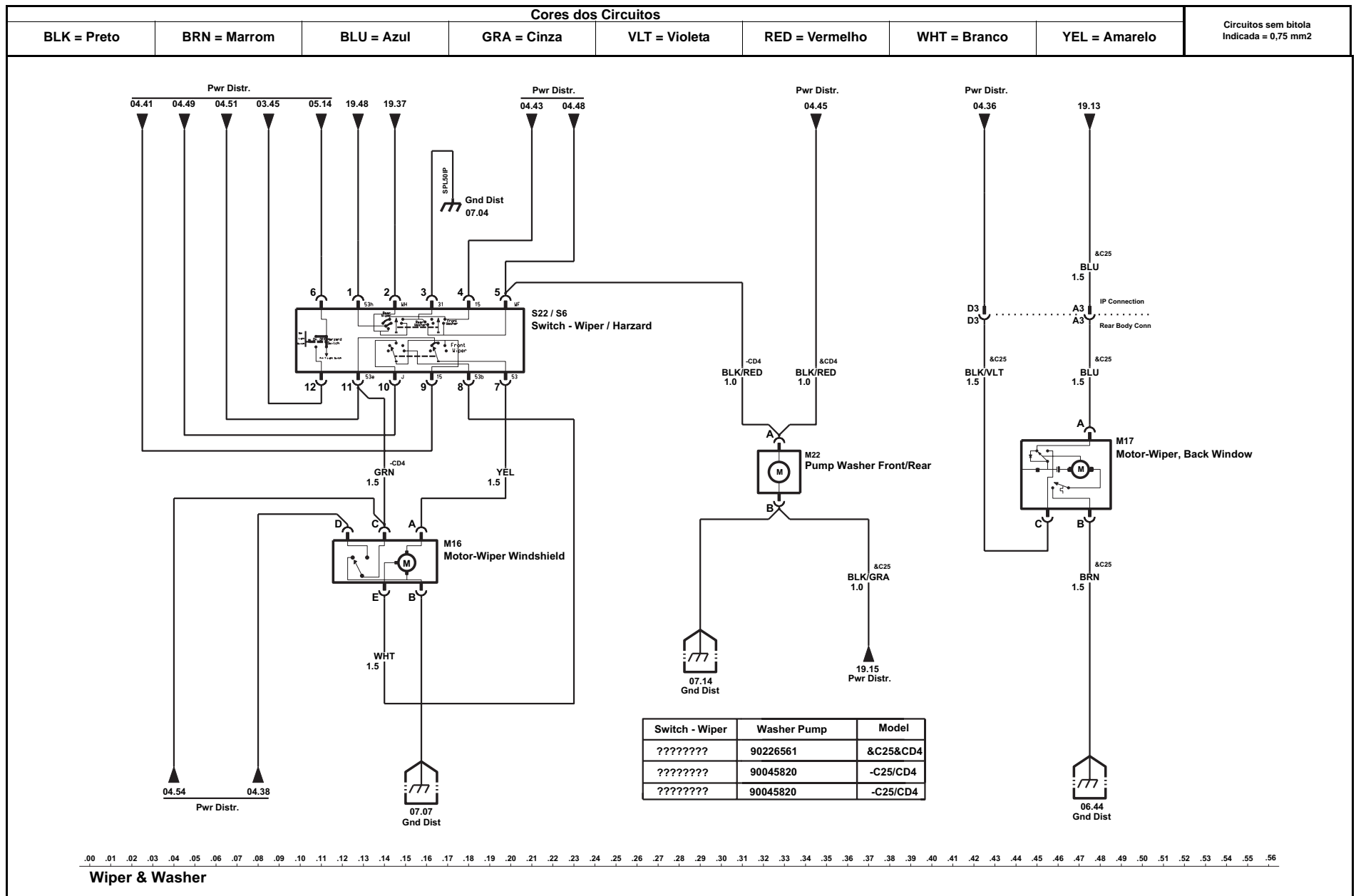

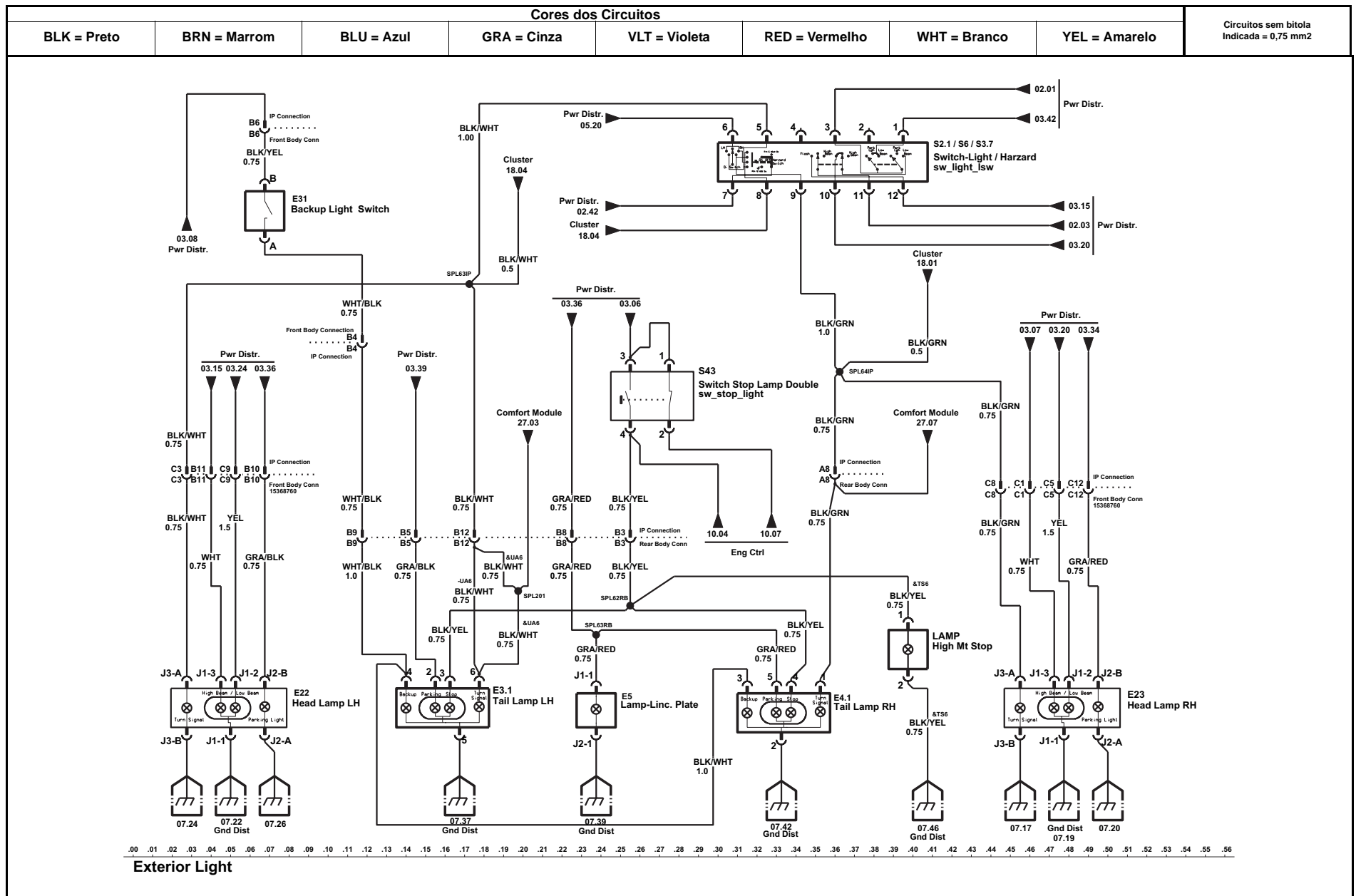

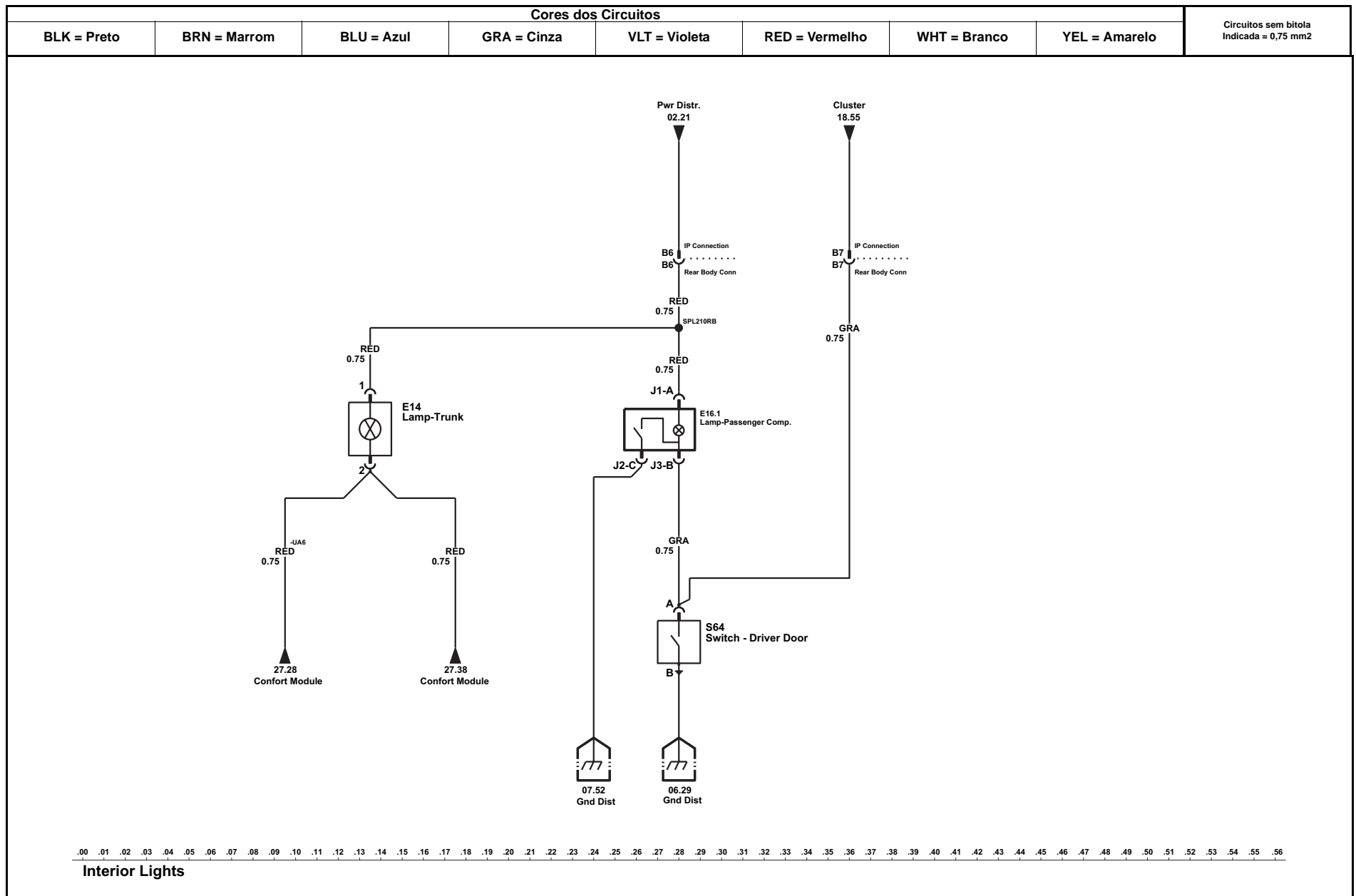

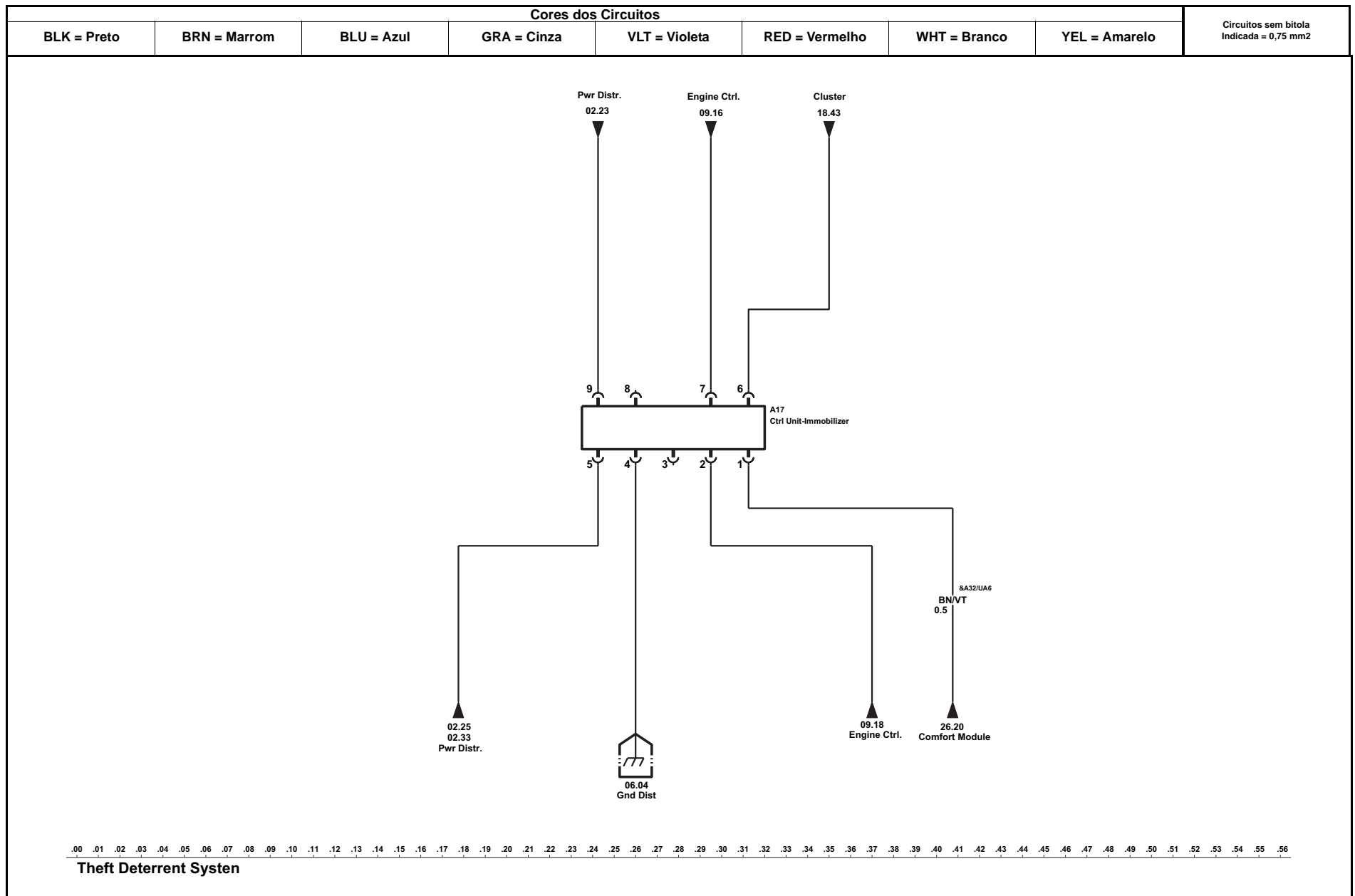

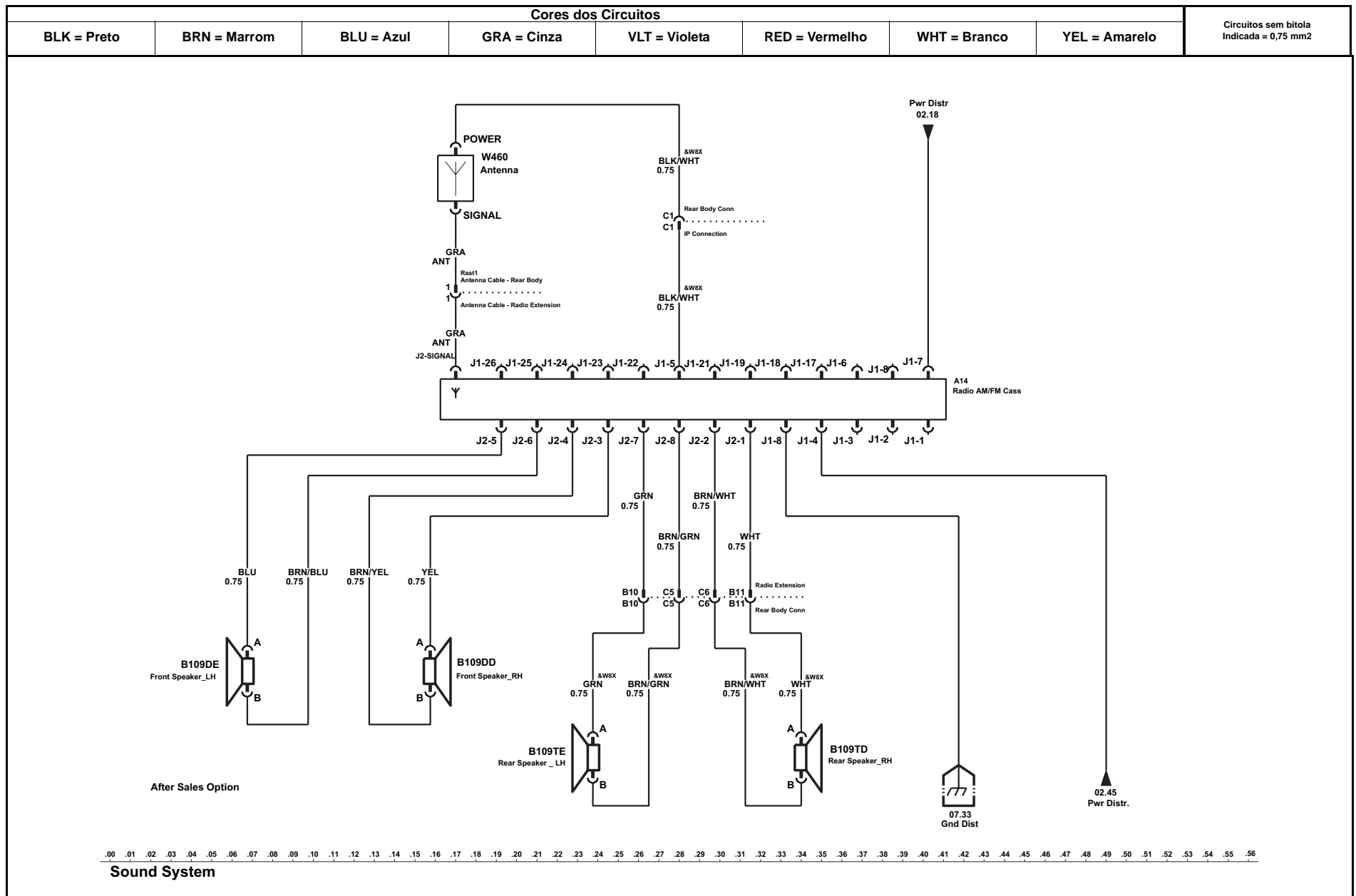

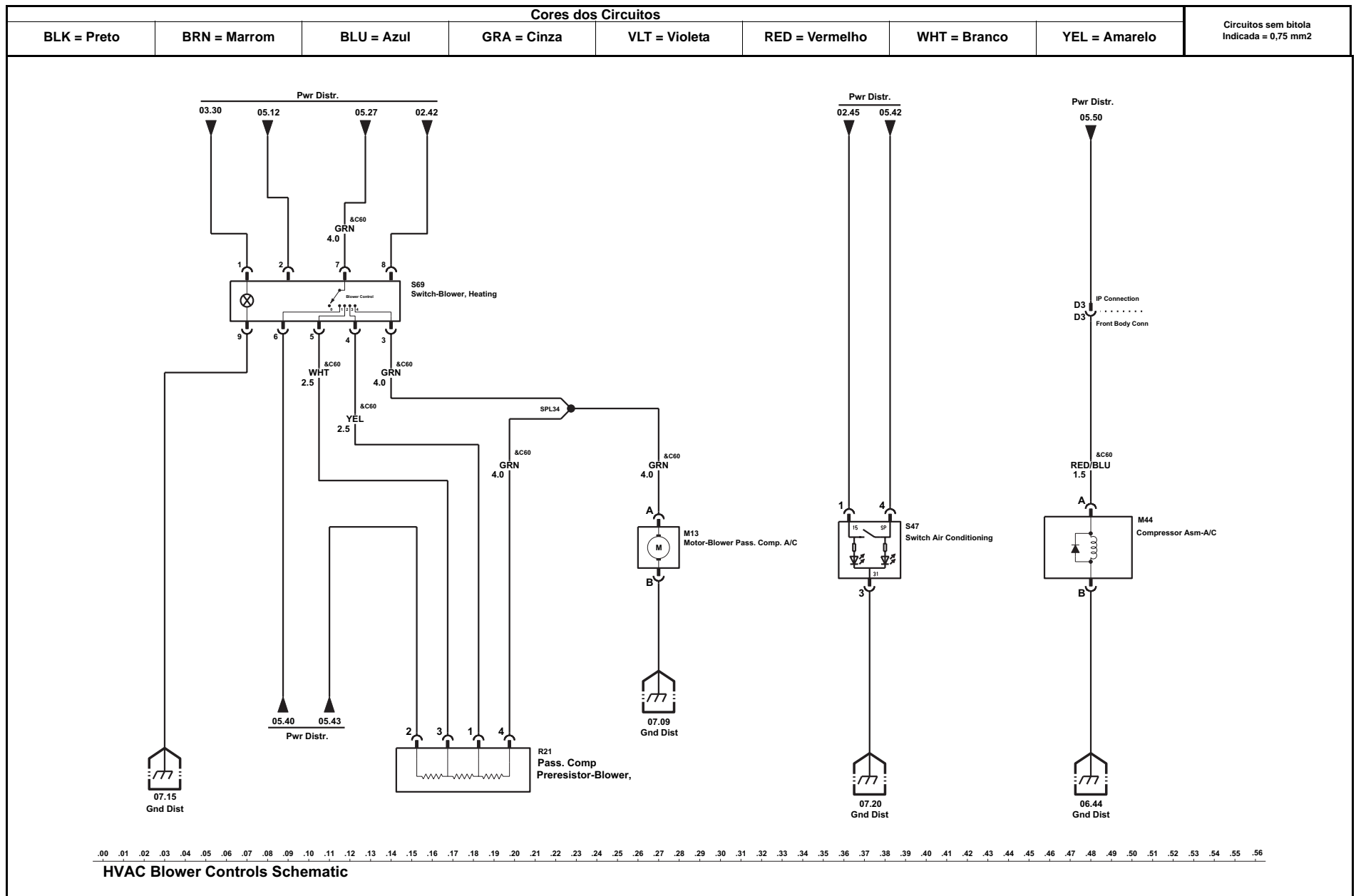

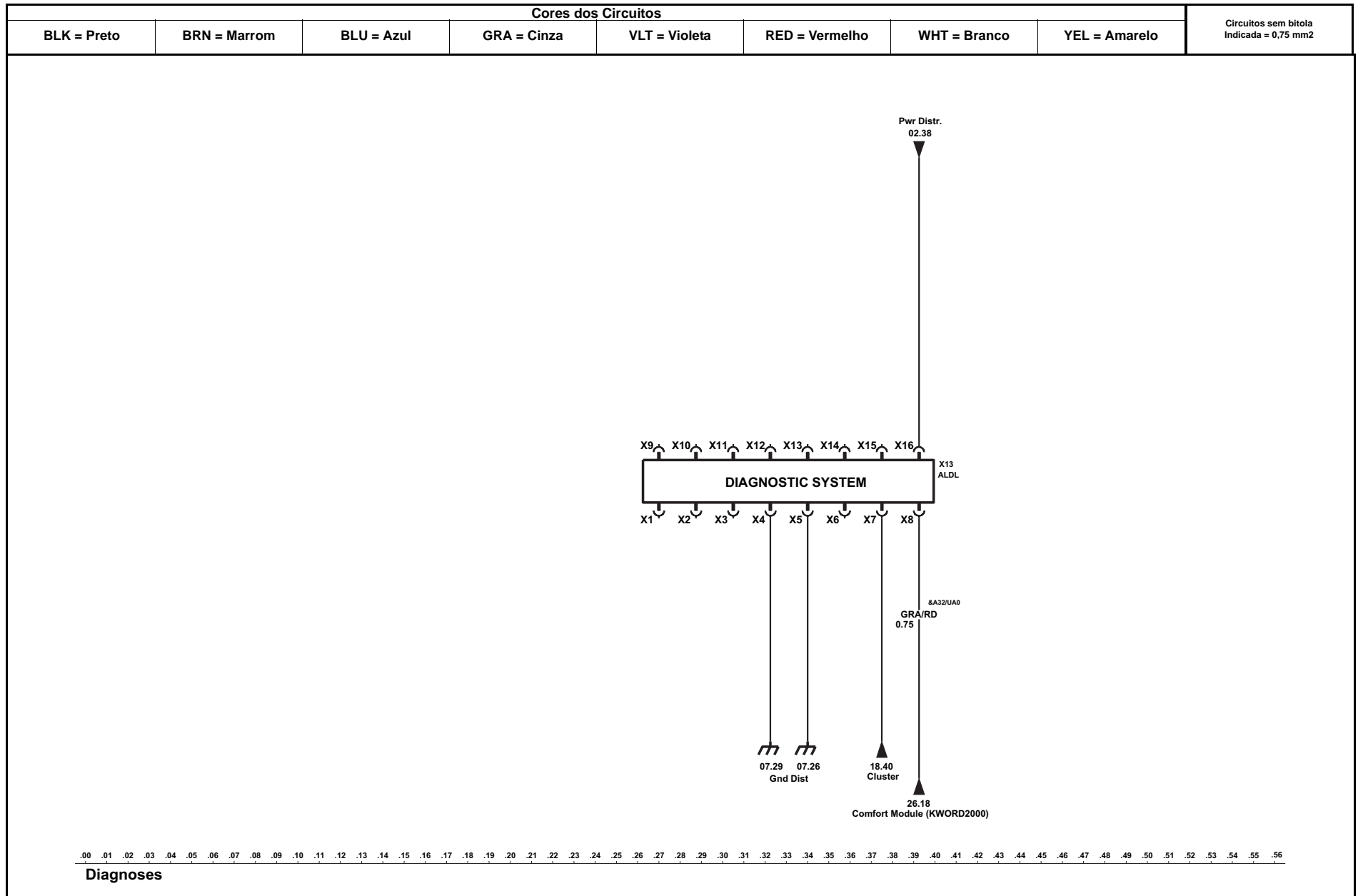

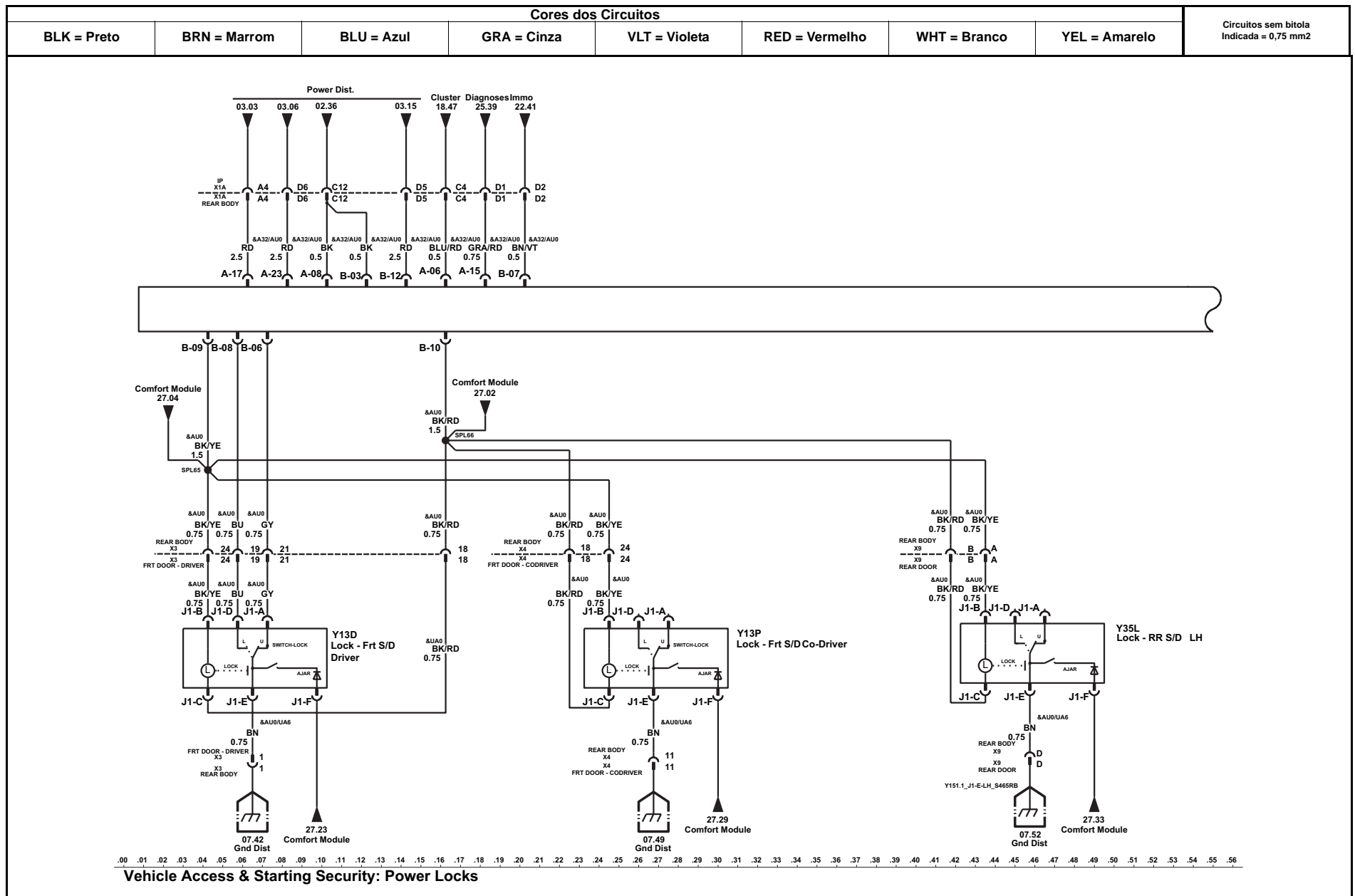

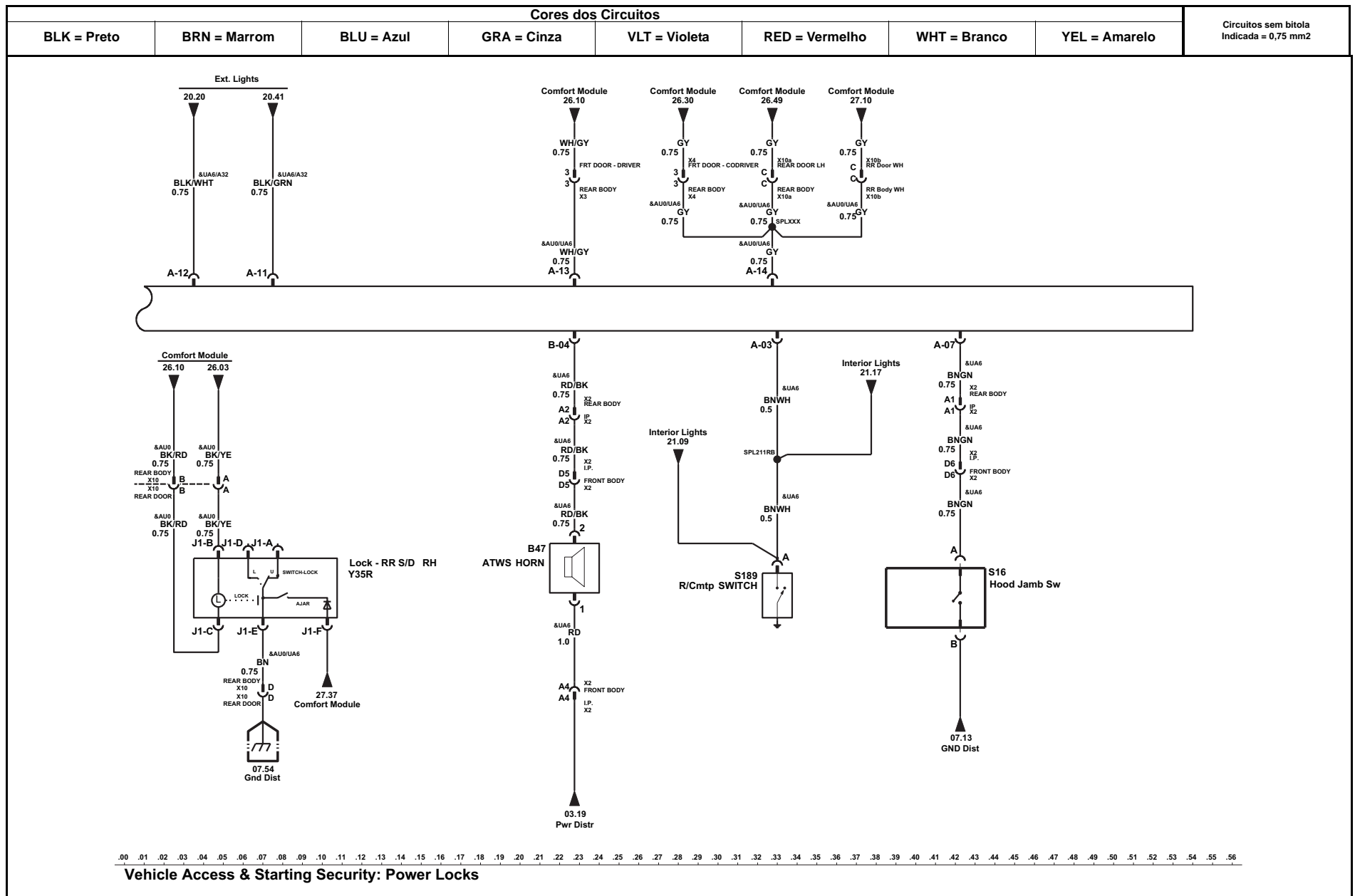

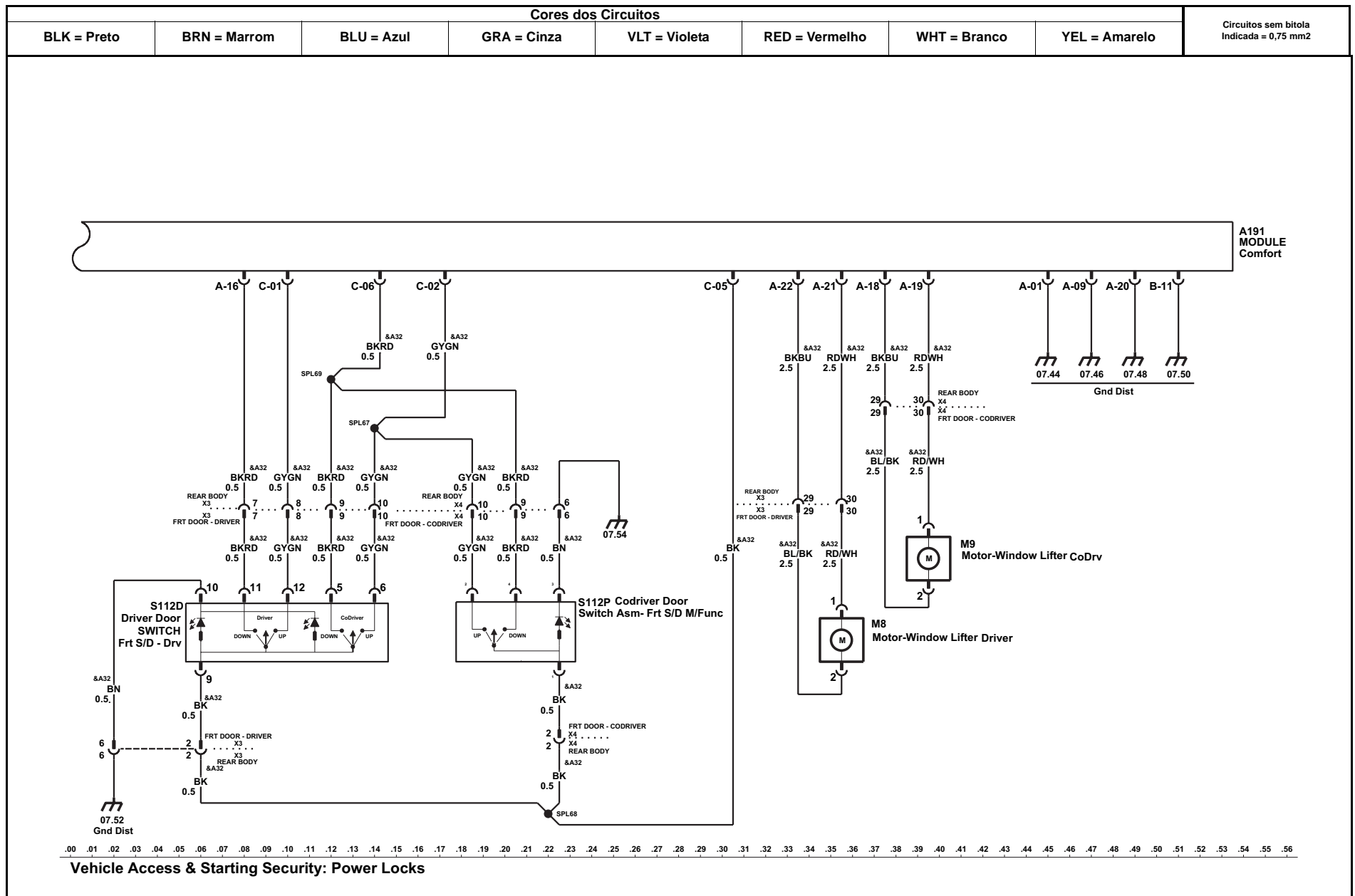

Códigos de Opção	
C25	Limpador do Vidro Traseiro
C49	Desembaçador do Vidro Traseiro
C60	Condicionador de Ar
CD4	Temporizador do Limpador de Pára-brisa
W8X	Previsão para Instalação de Rádio
U16	Tacômetro
LNL	Motor 1.0 Flex
NF2	Motor VHC 1.0 Gasolina Com Sensor Lambda Aquecido
L19	Motor VHC 1.0 Gasolina
L11	Motor VHC 1.0 Gasolina Exportação
LQS	Motor VHC 1.4 Gasolina, Local / Exportação

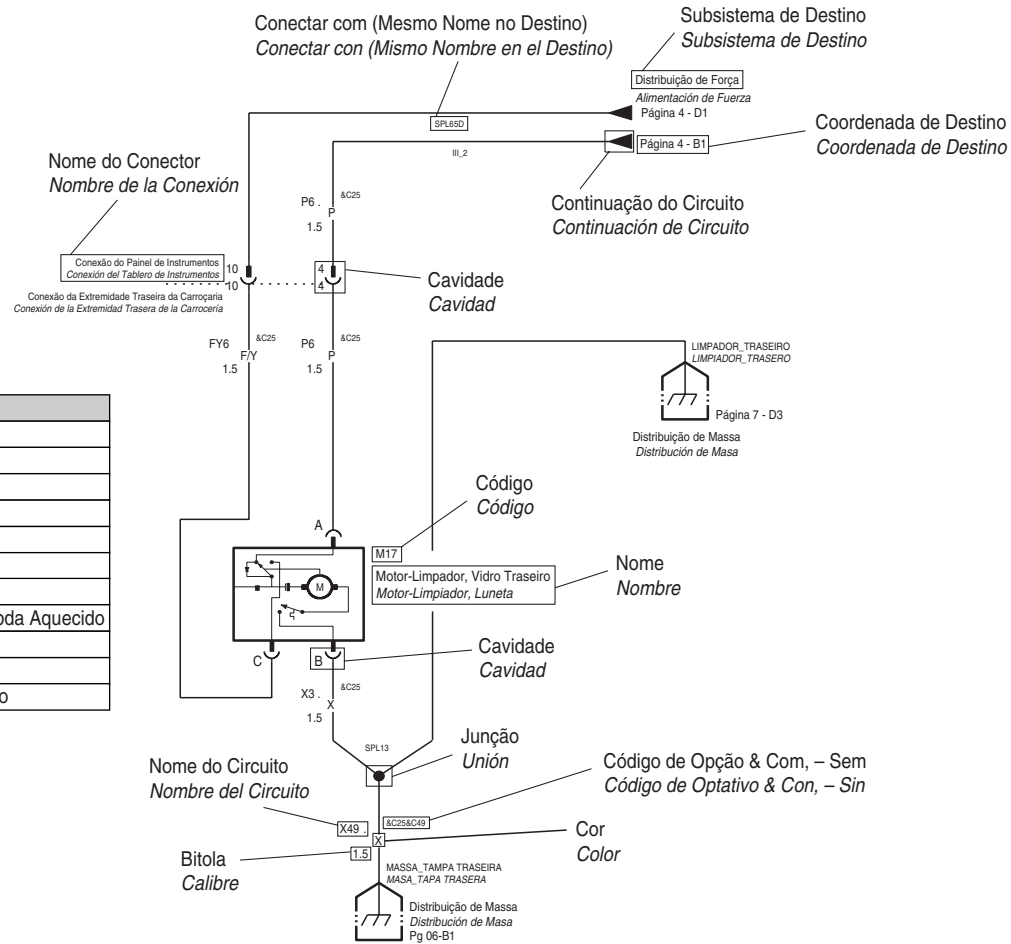

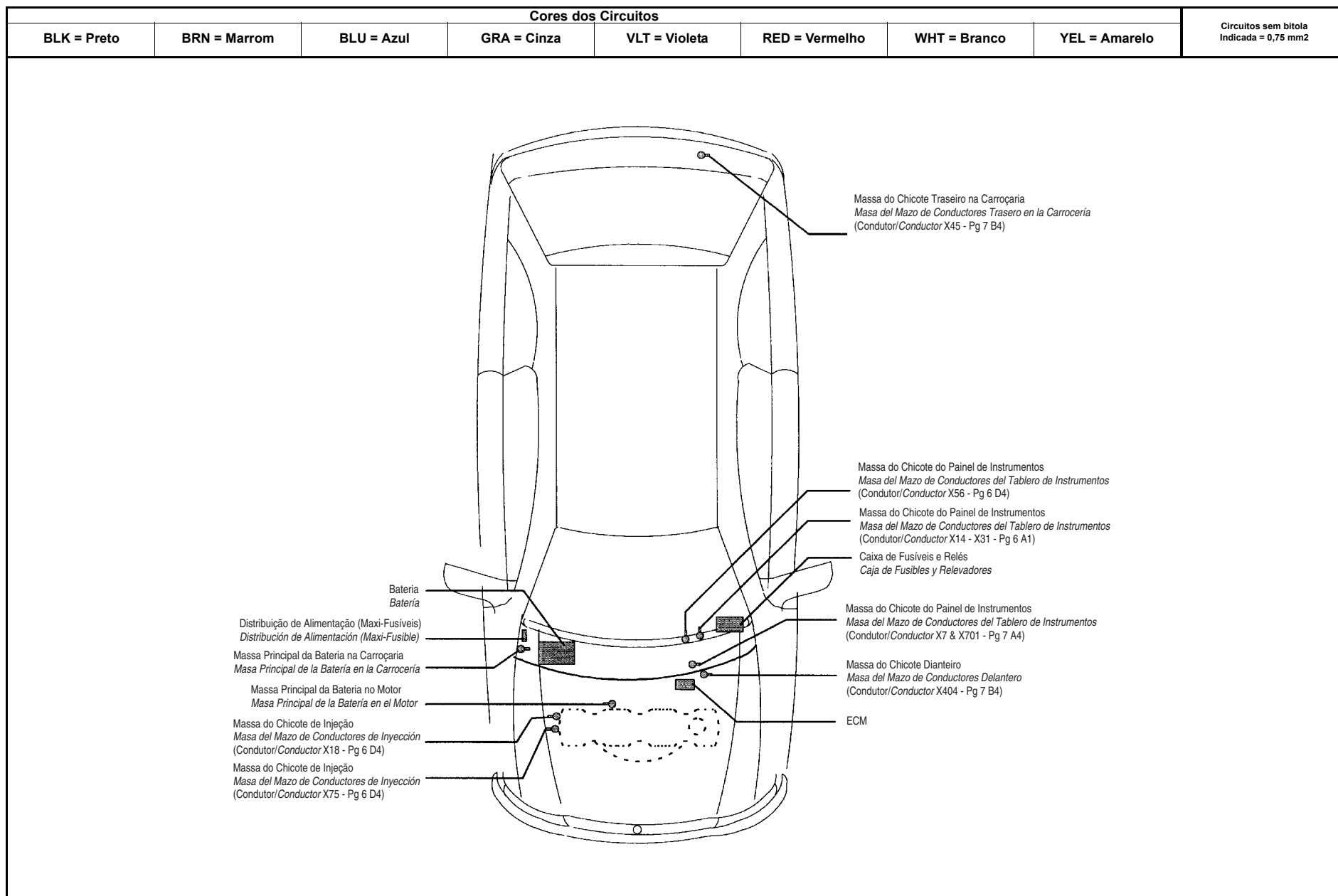

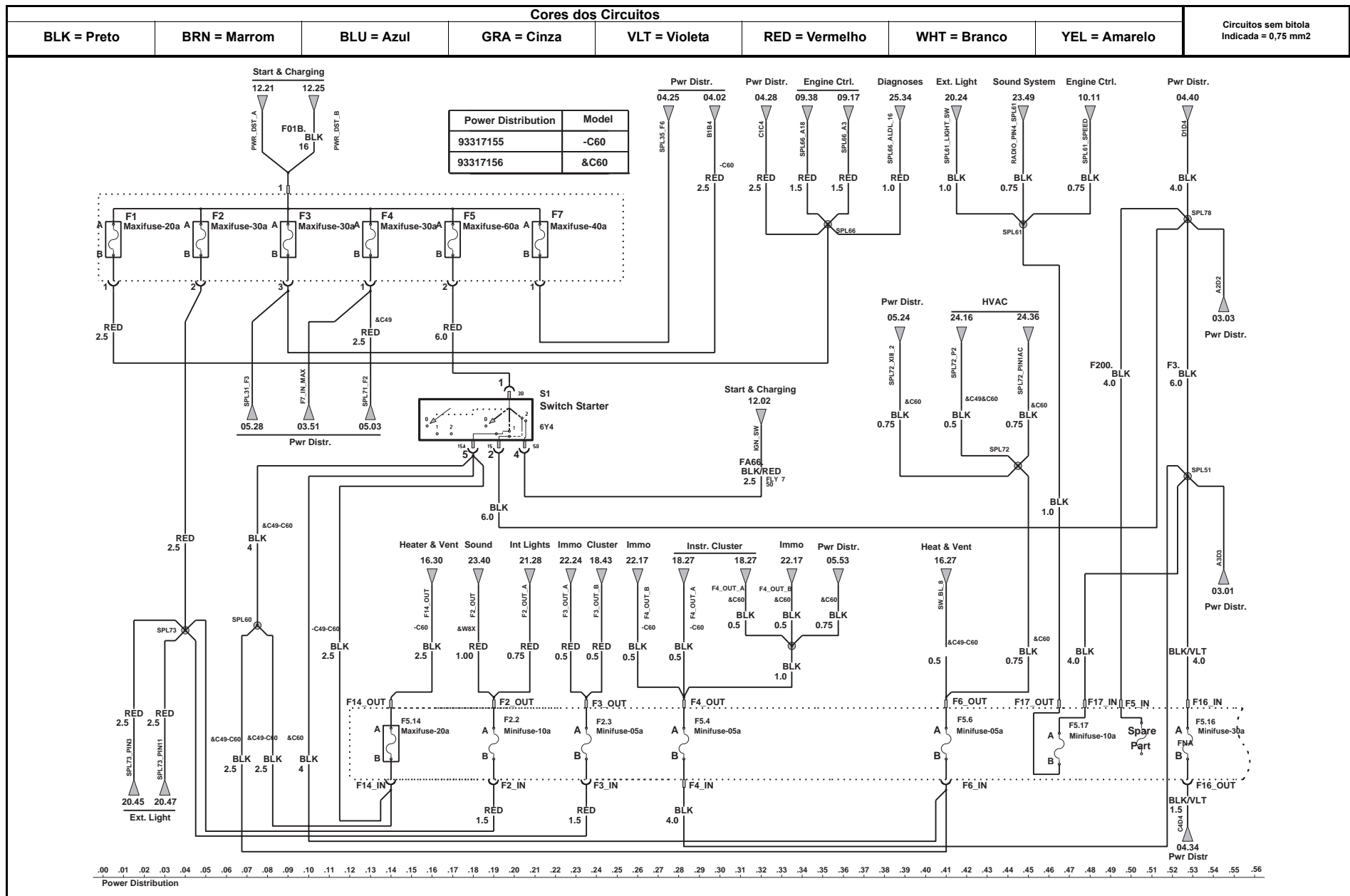

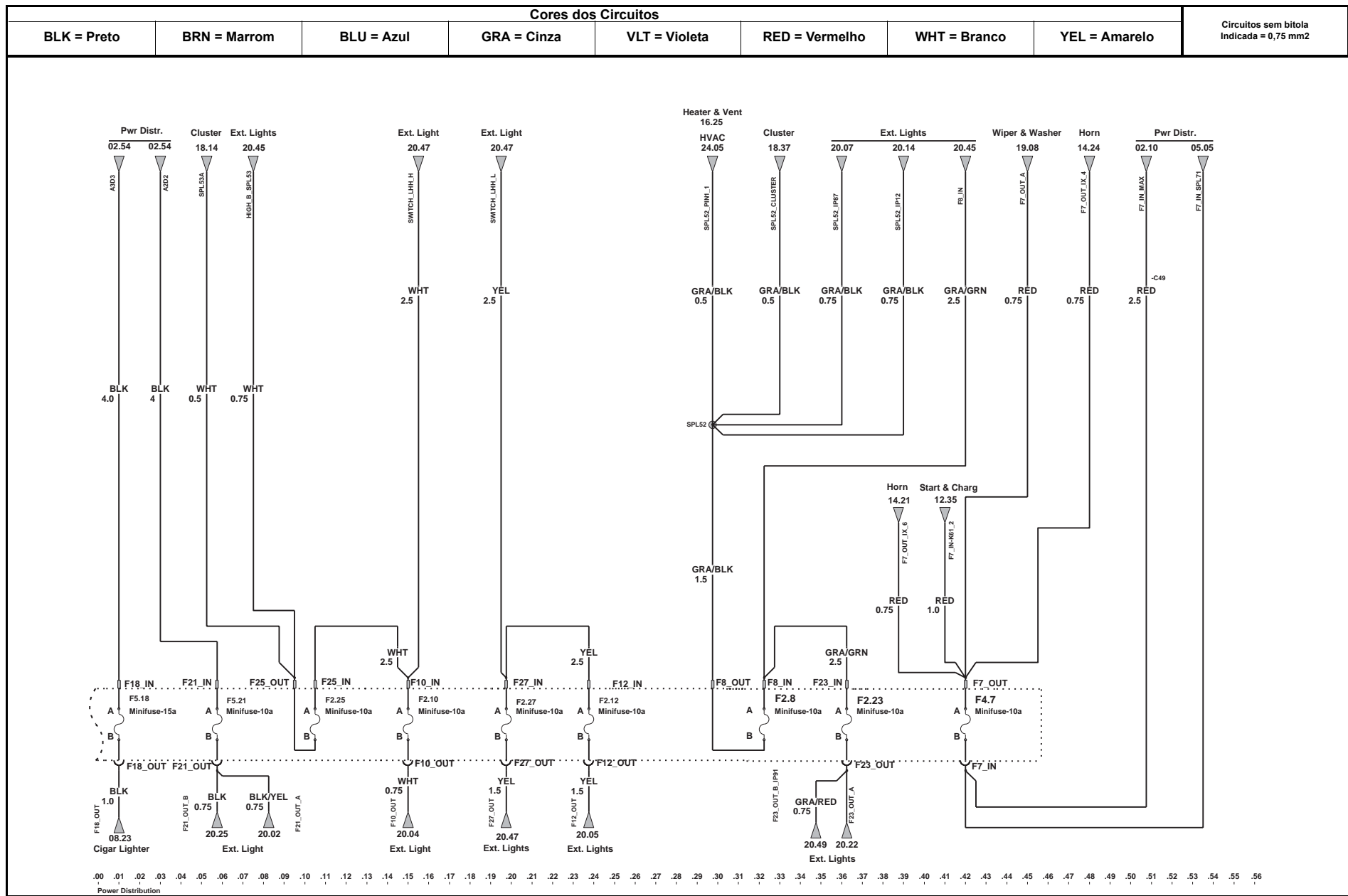

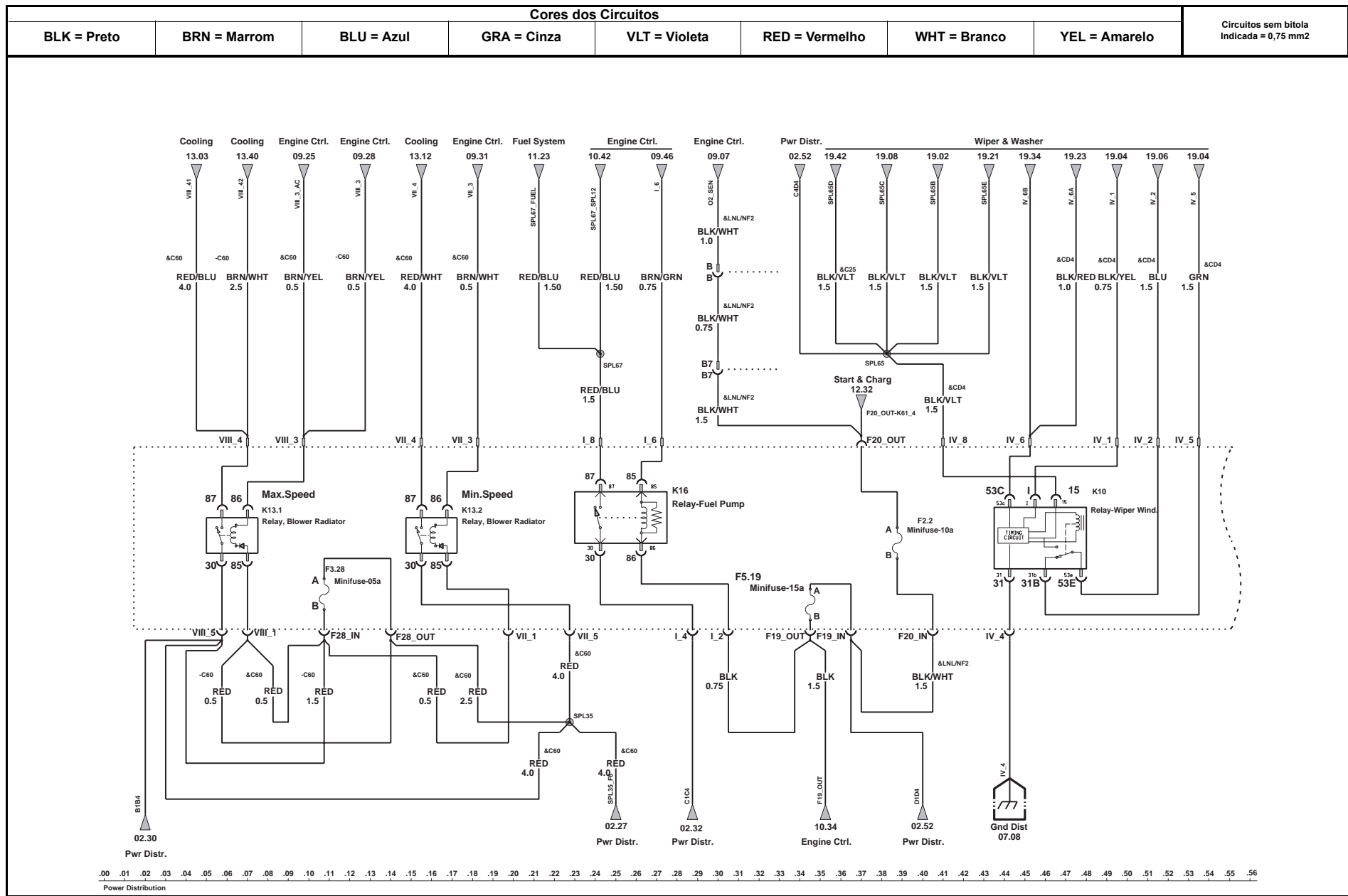

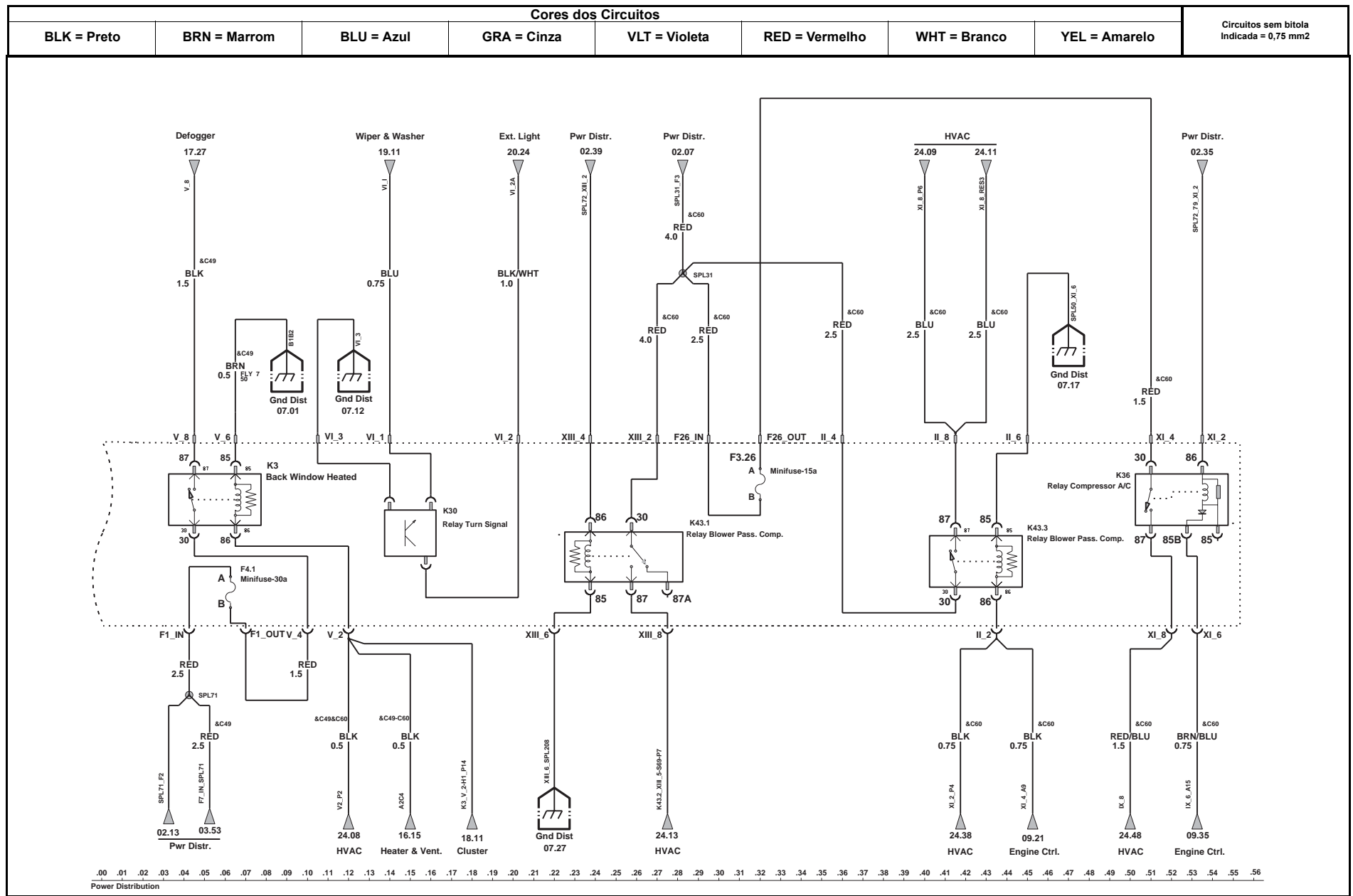

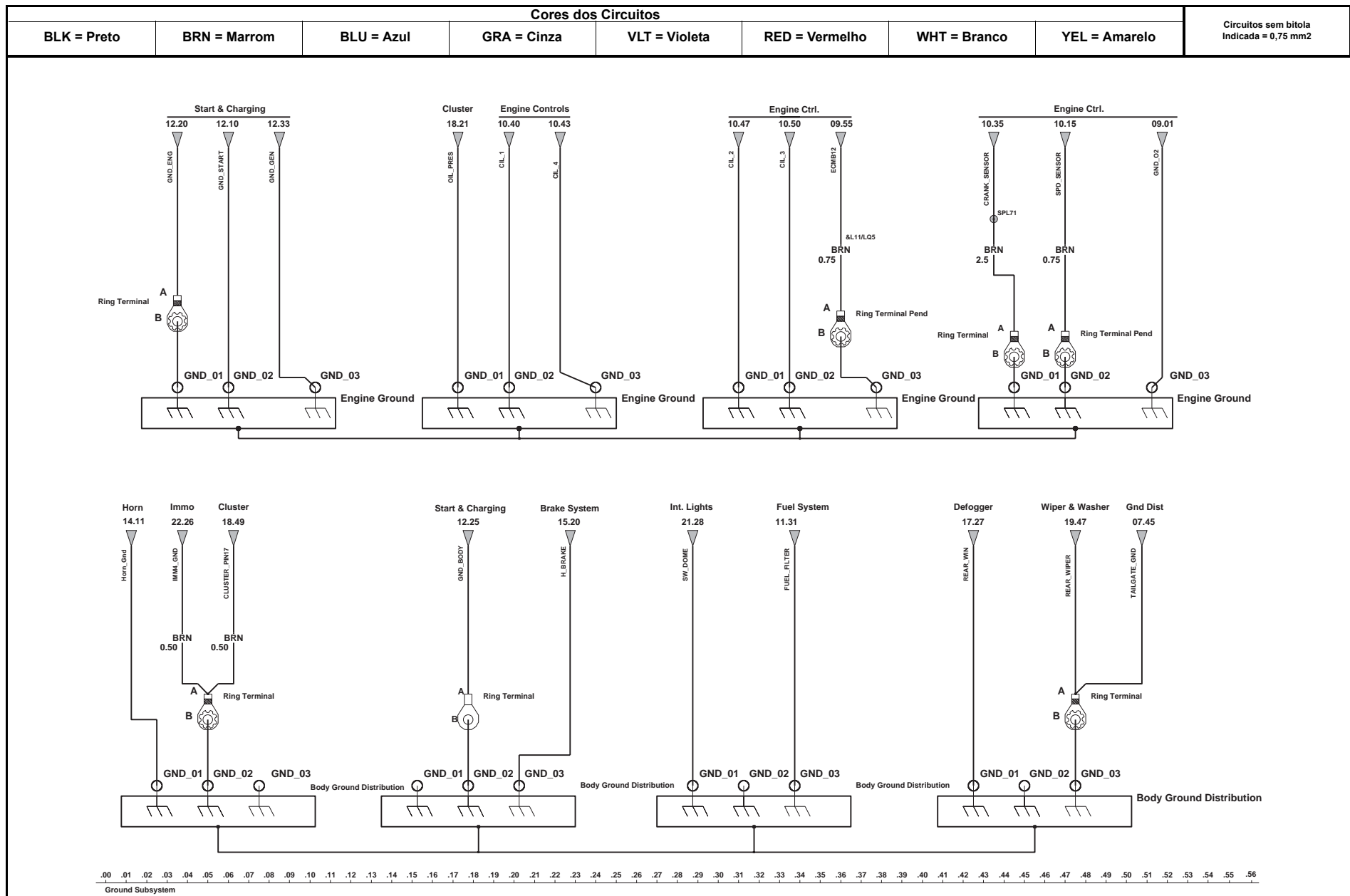

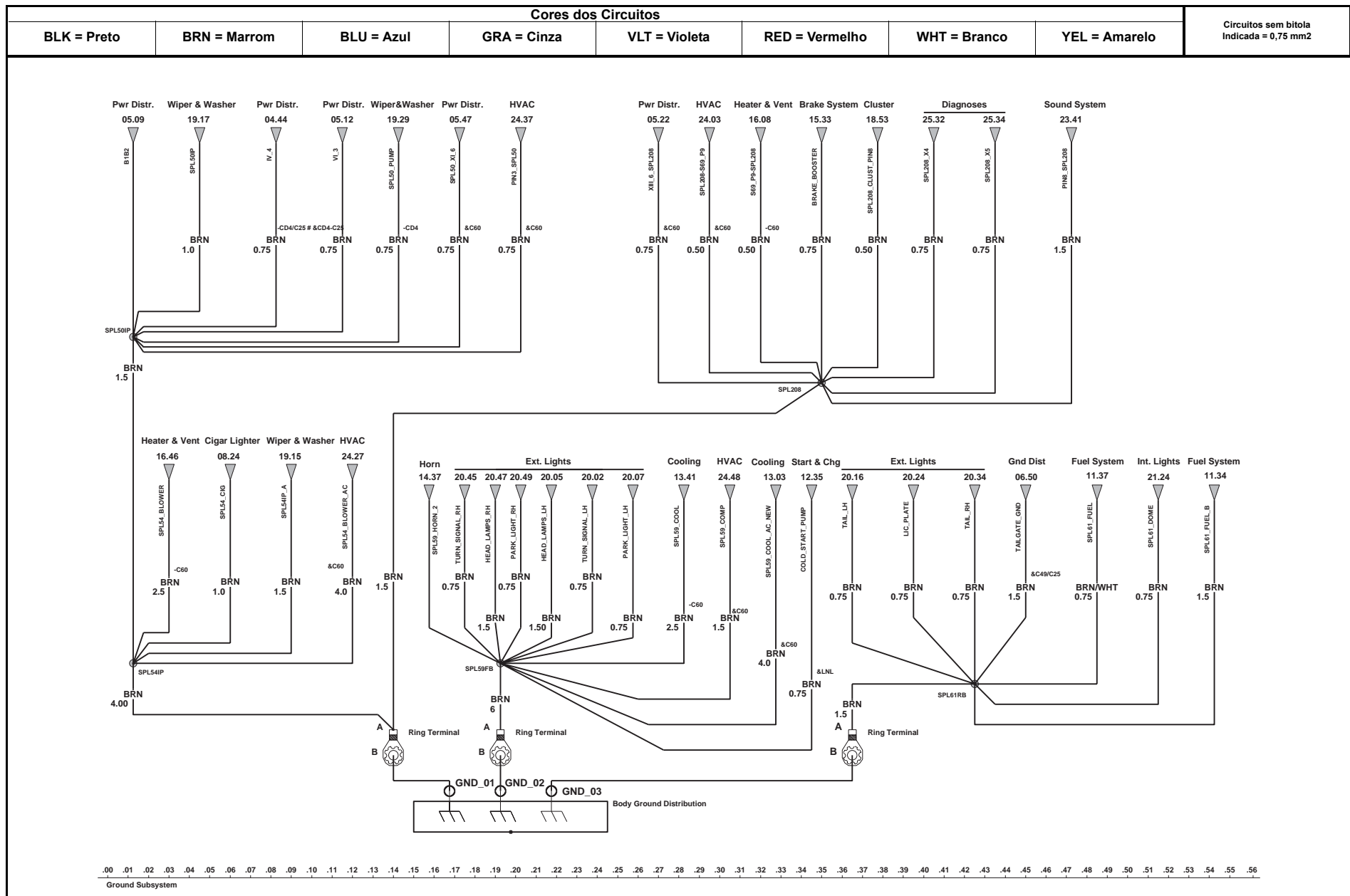

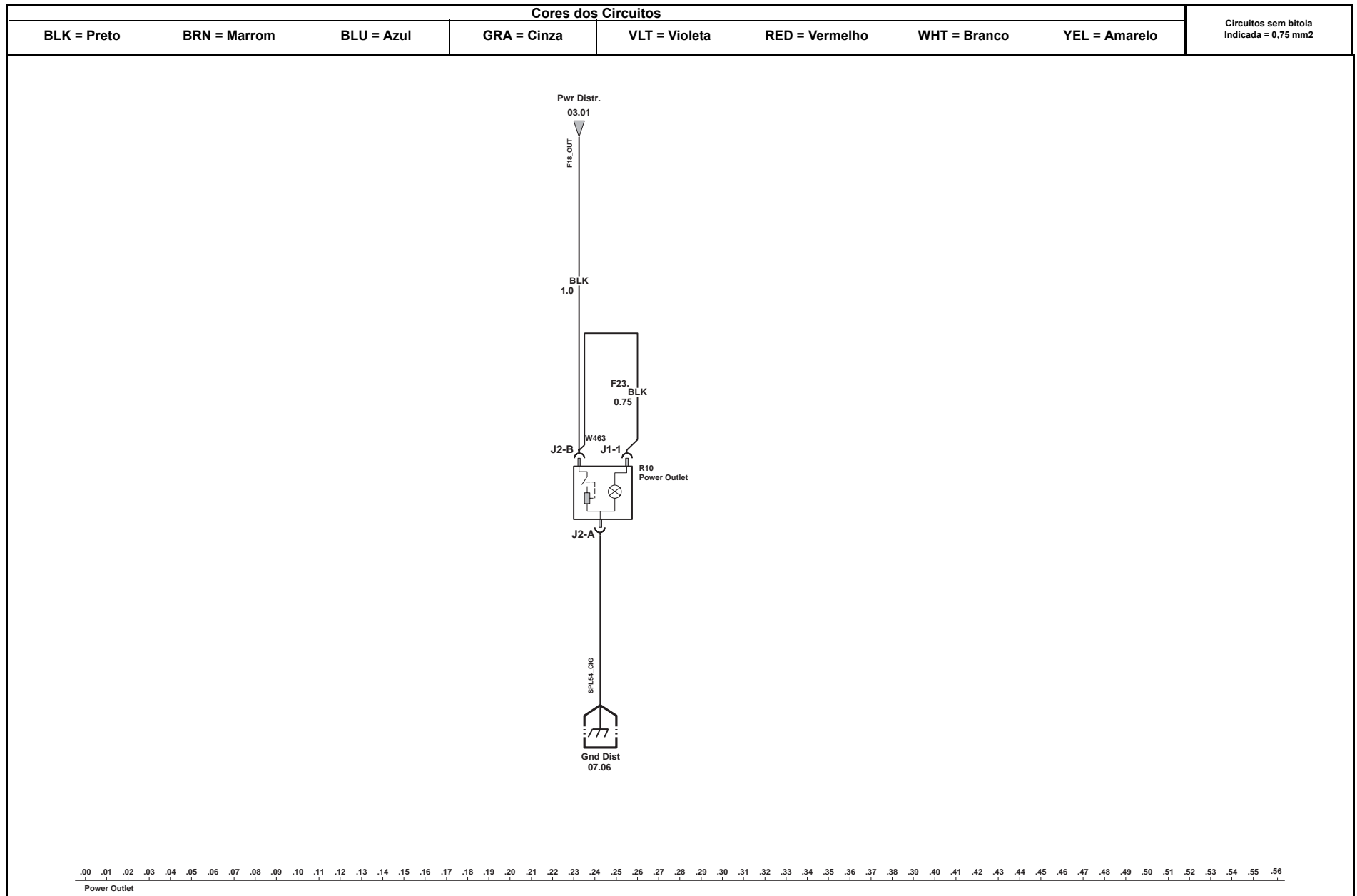

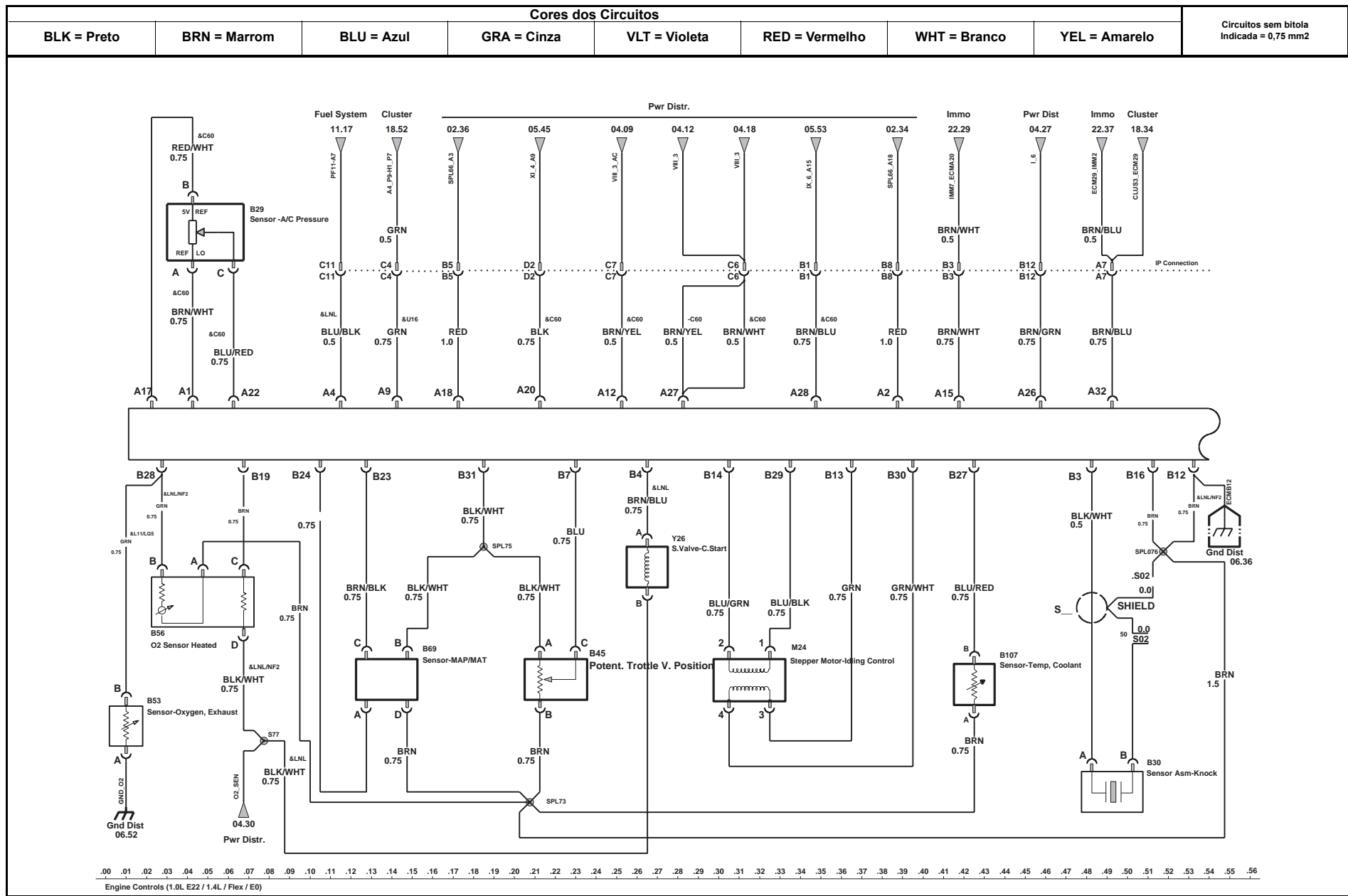

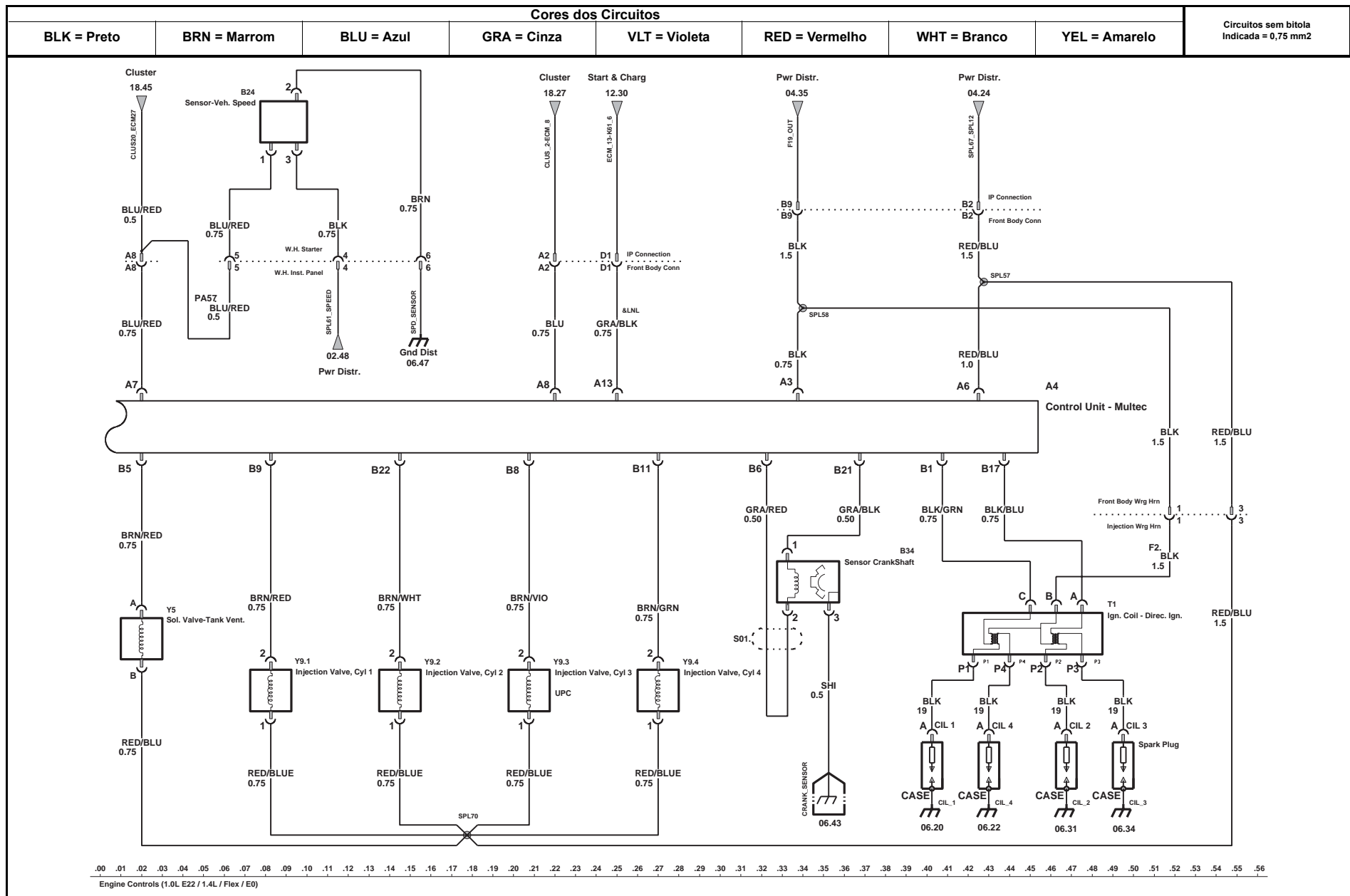

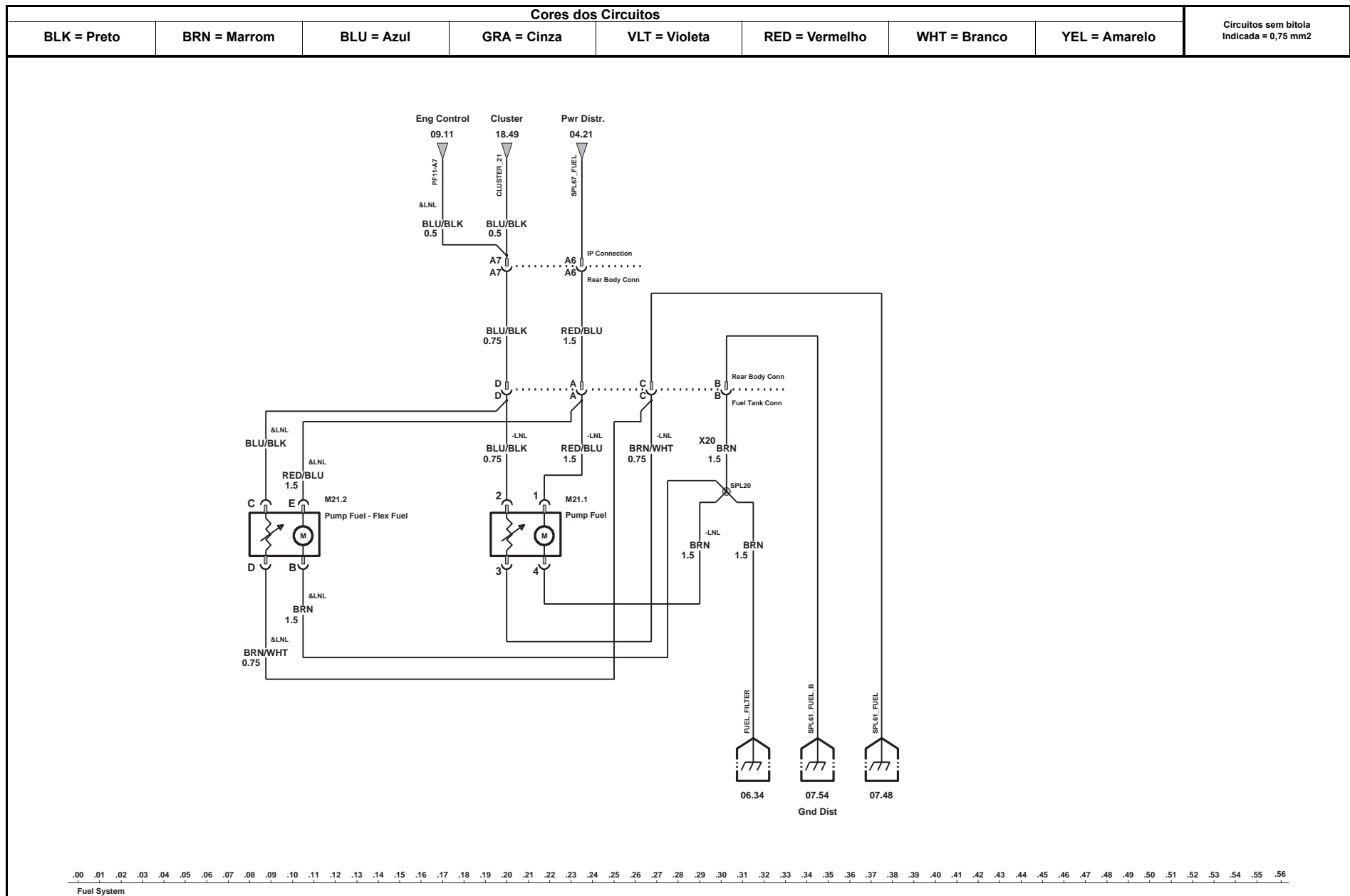

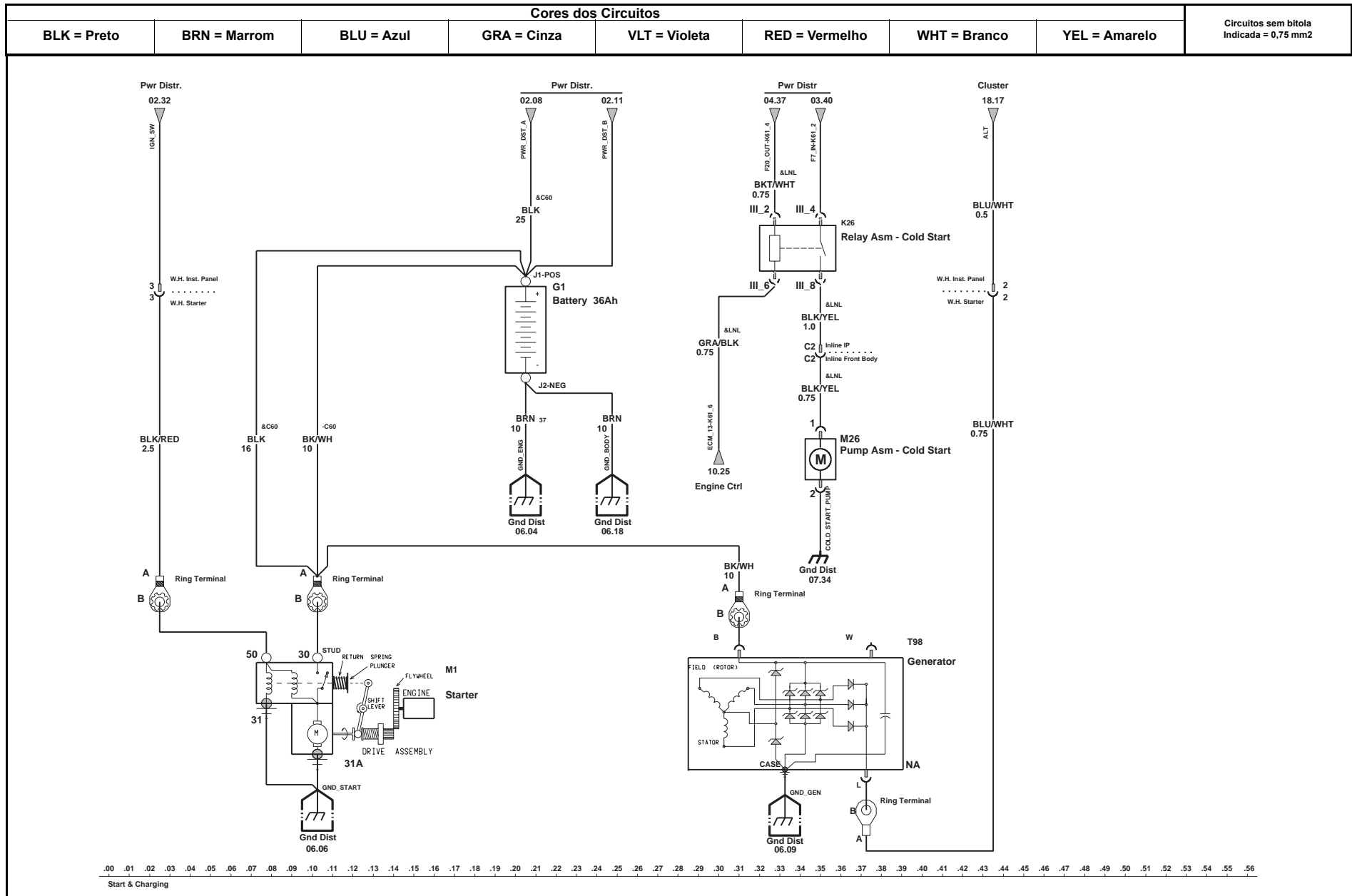

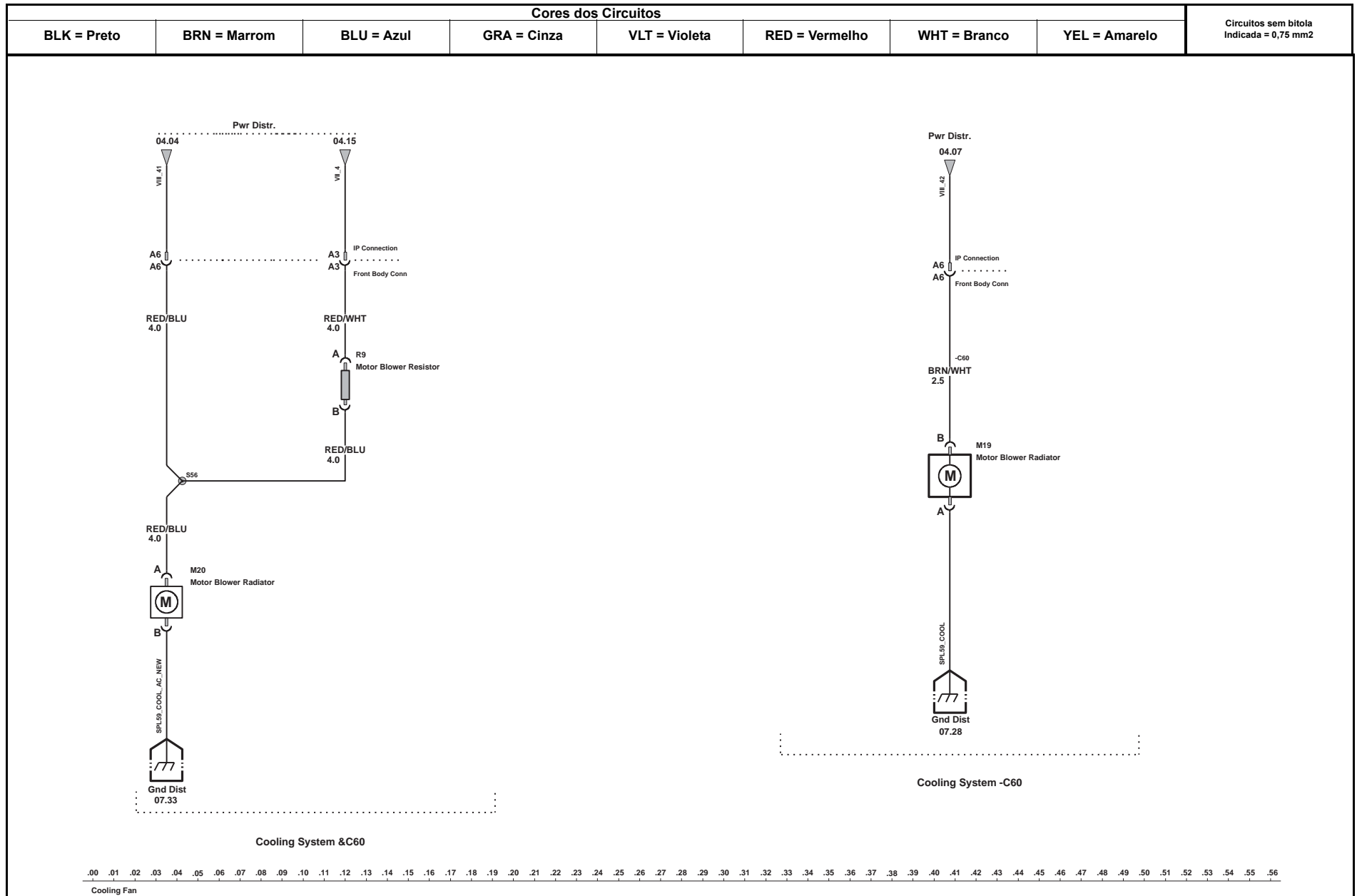

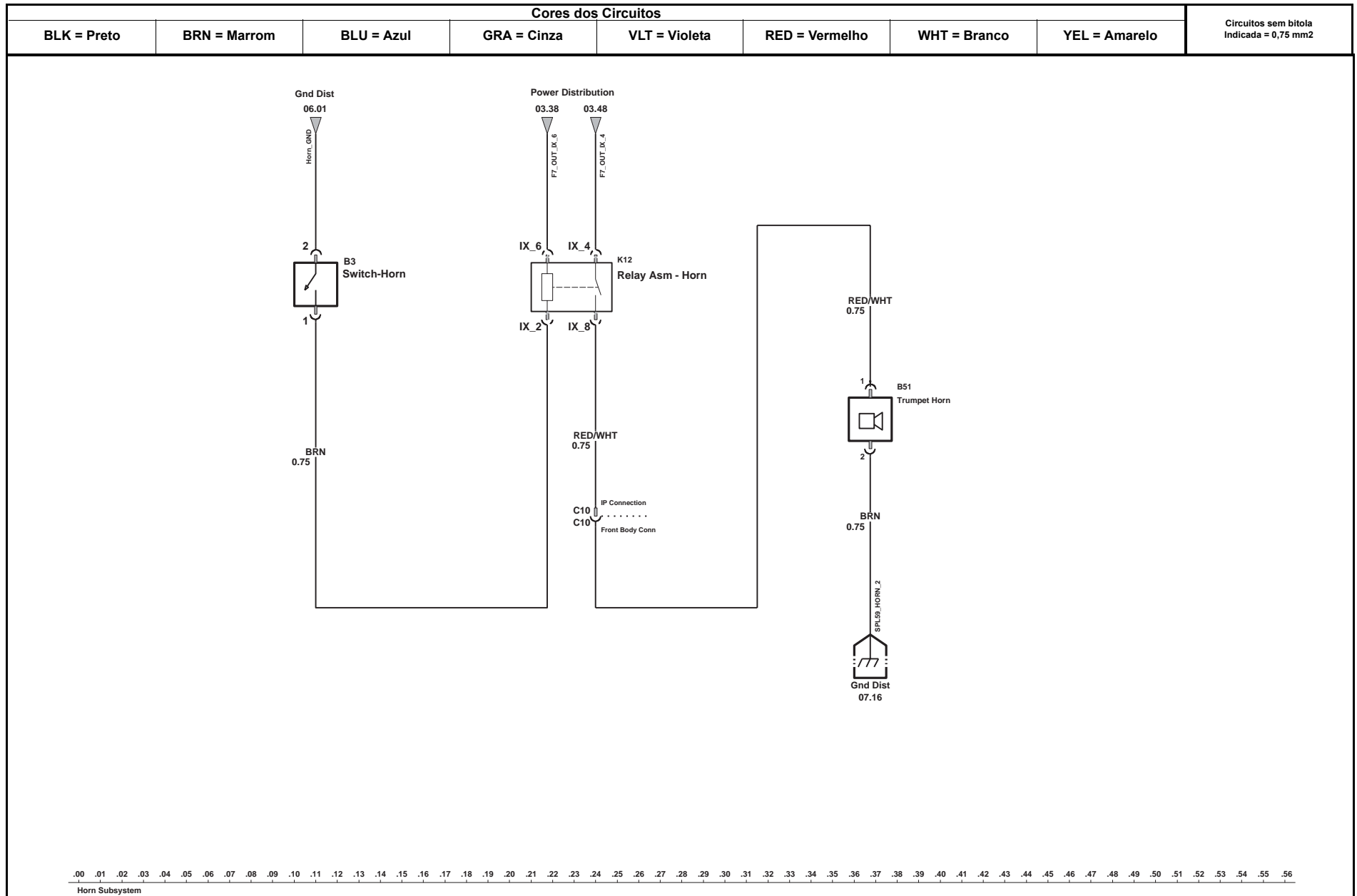

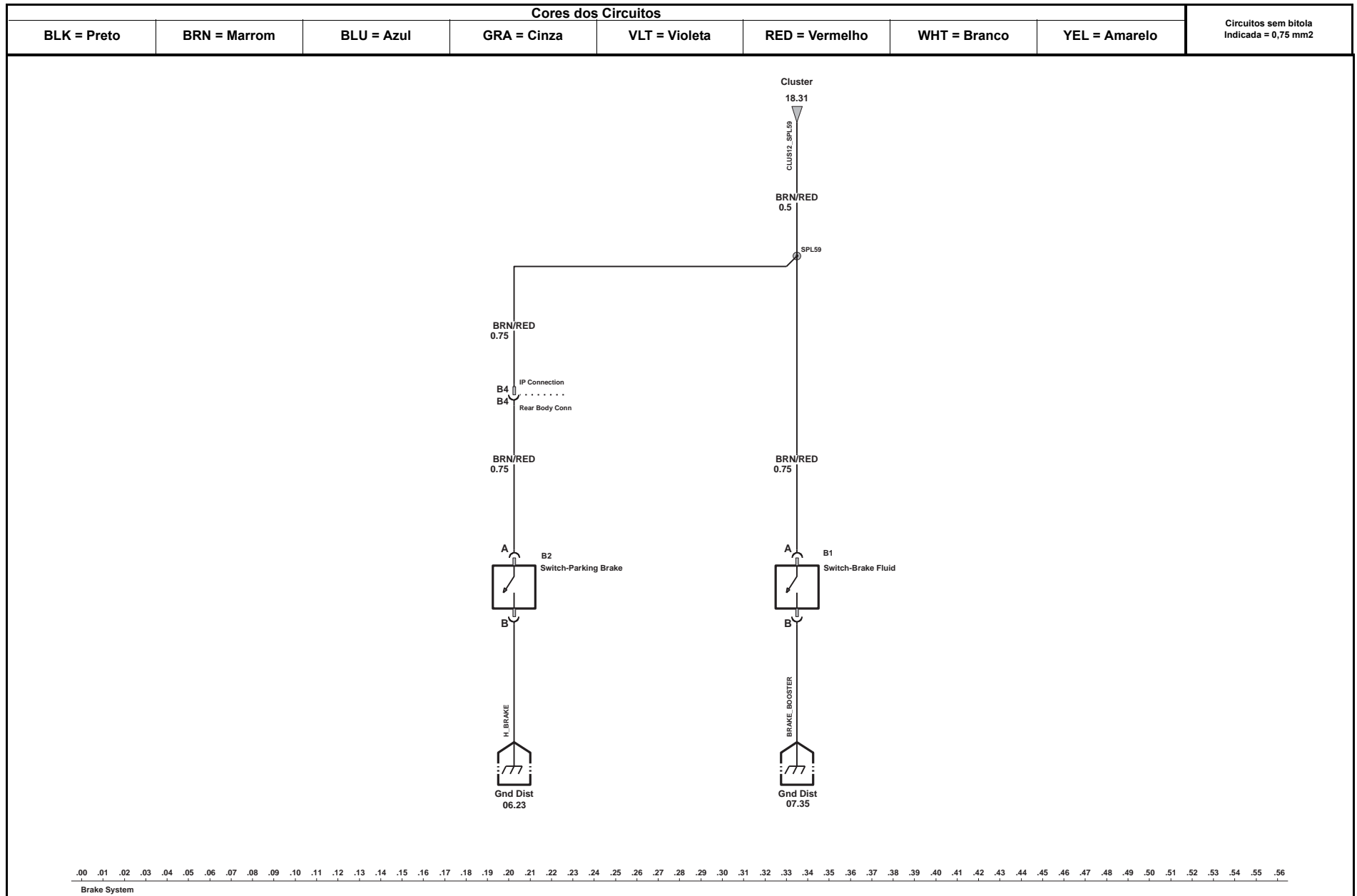

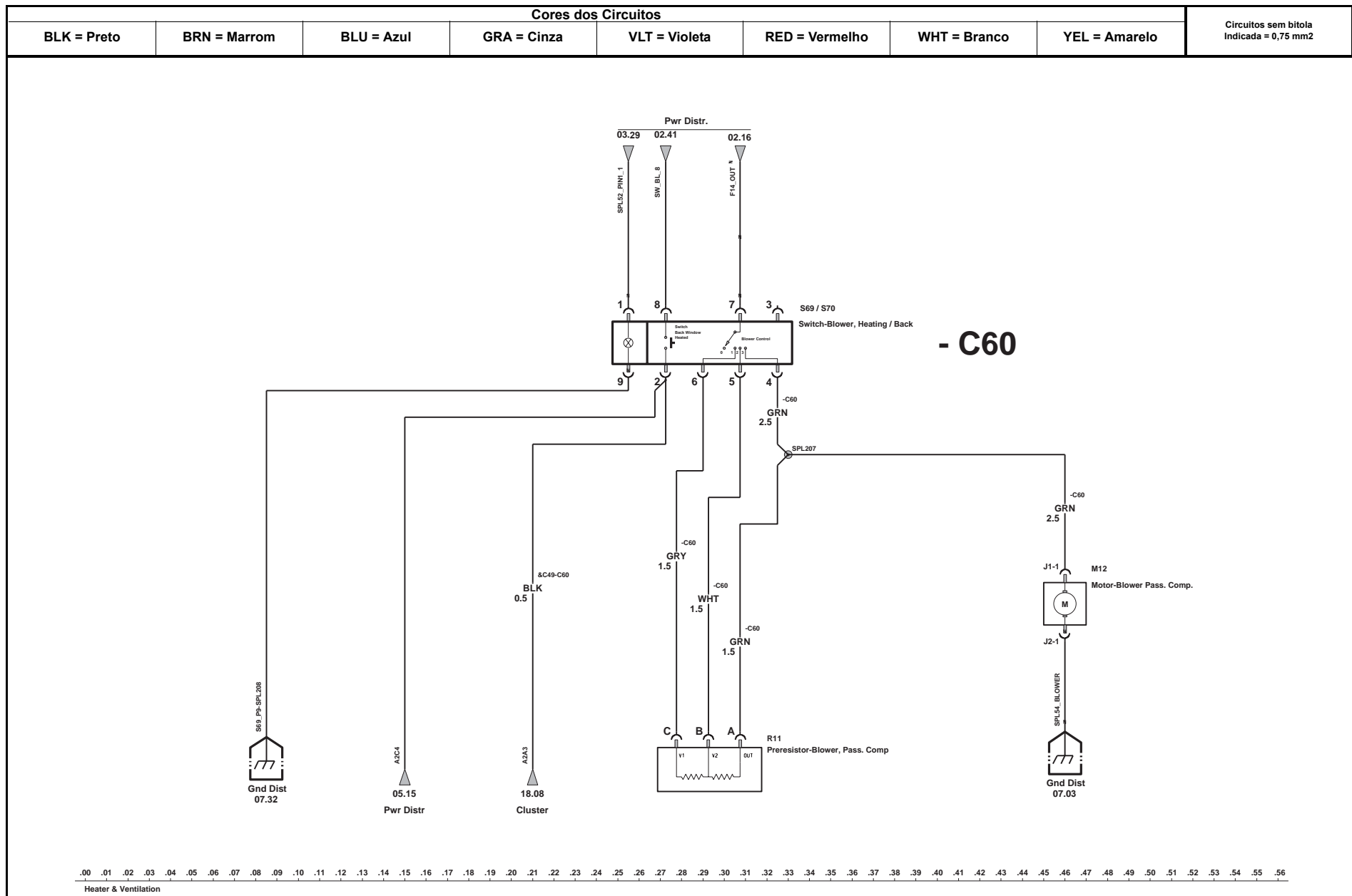

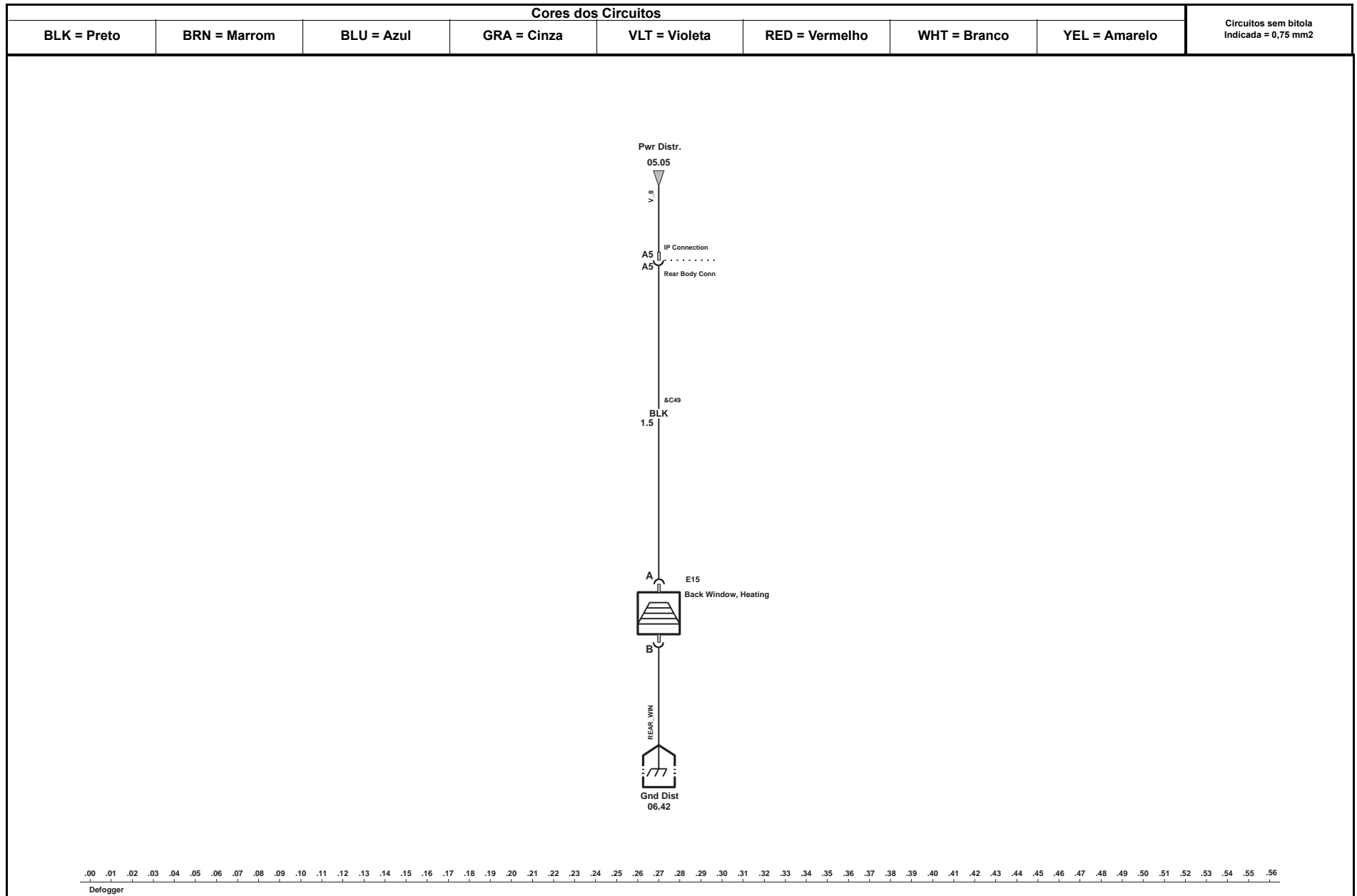

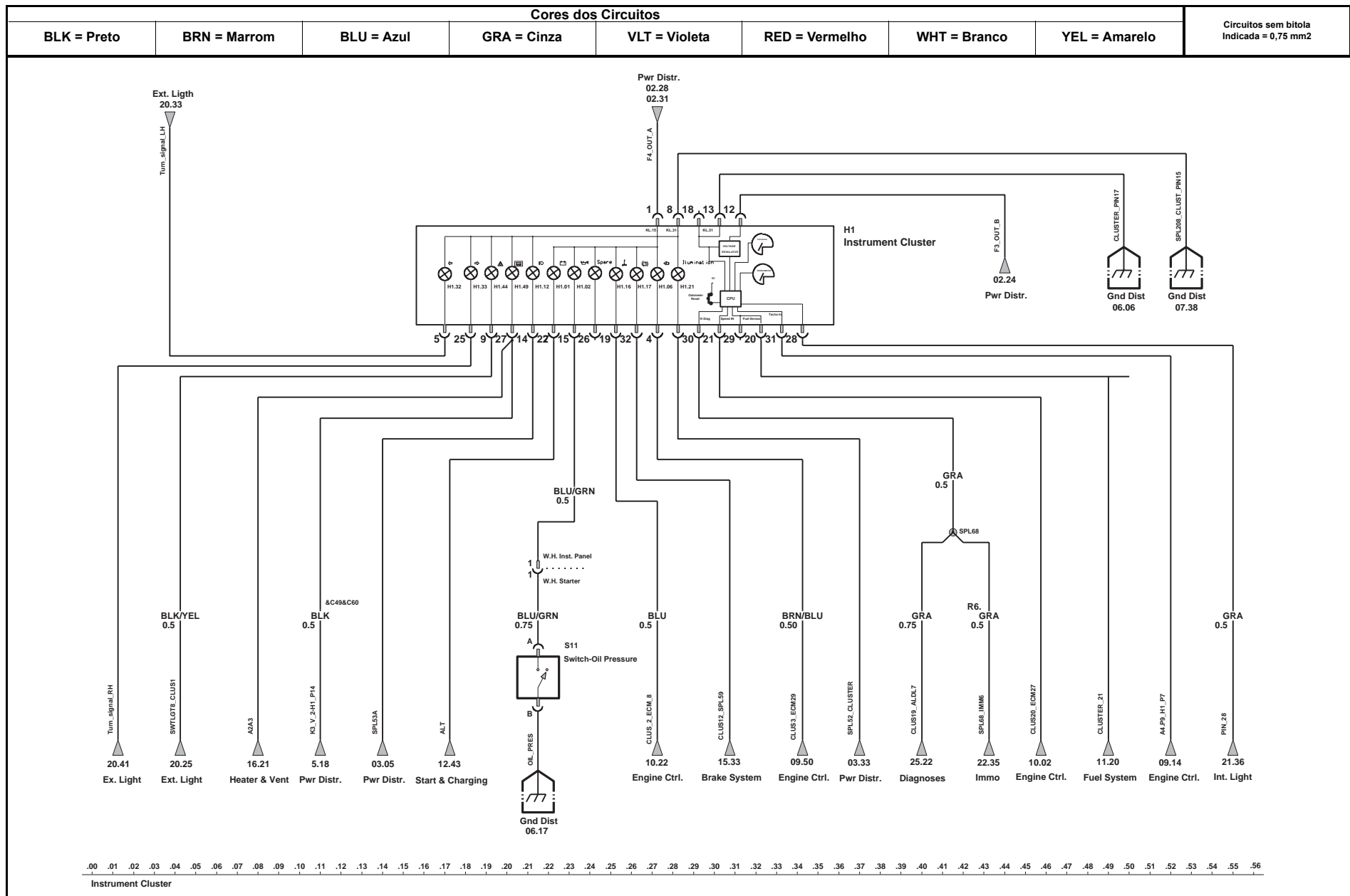

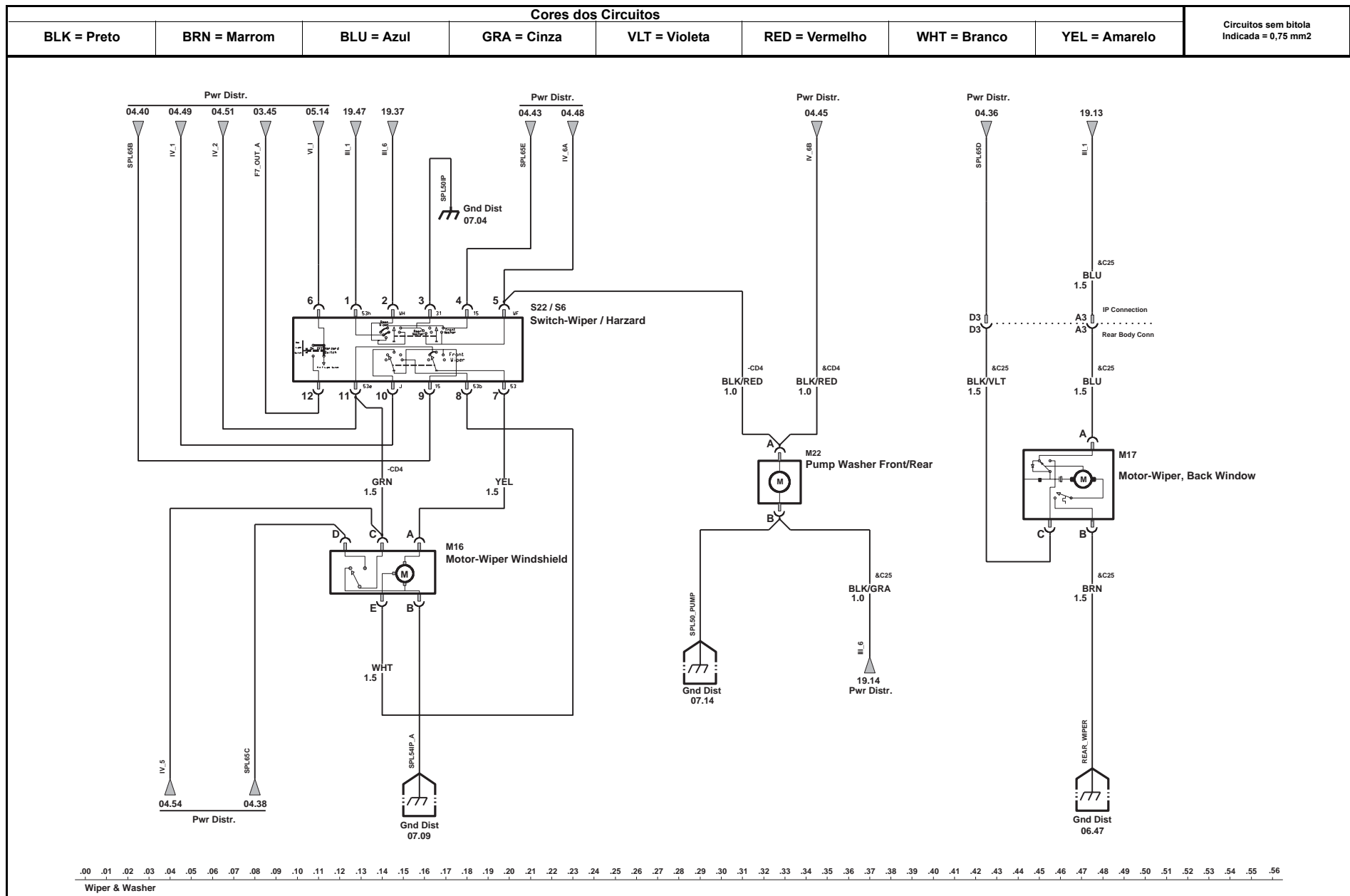

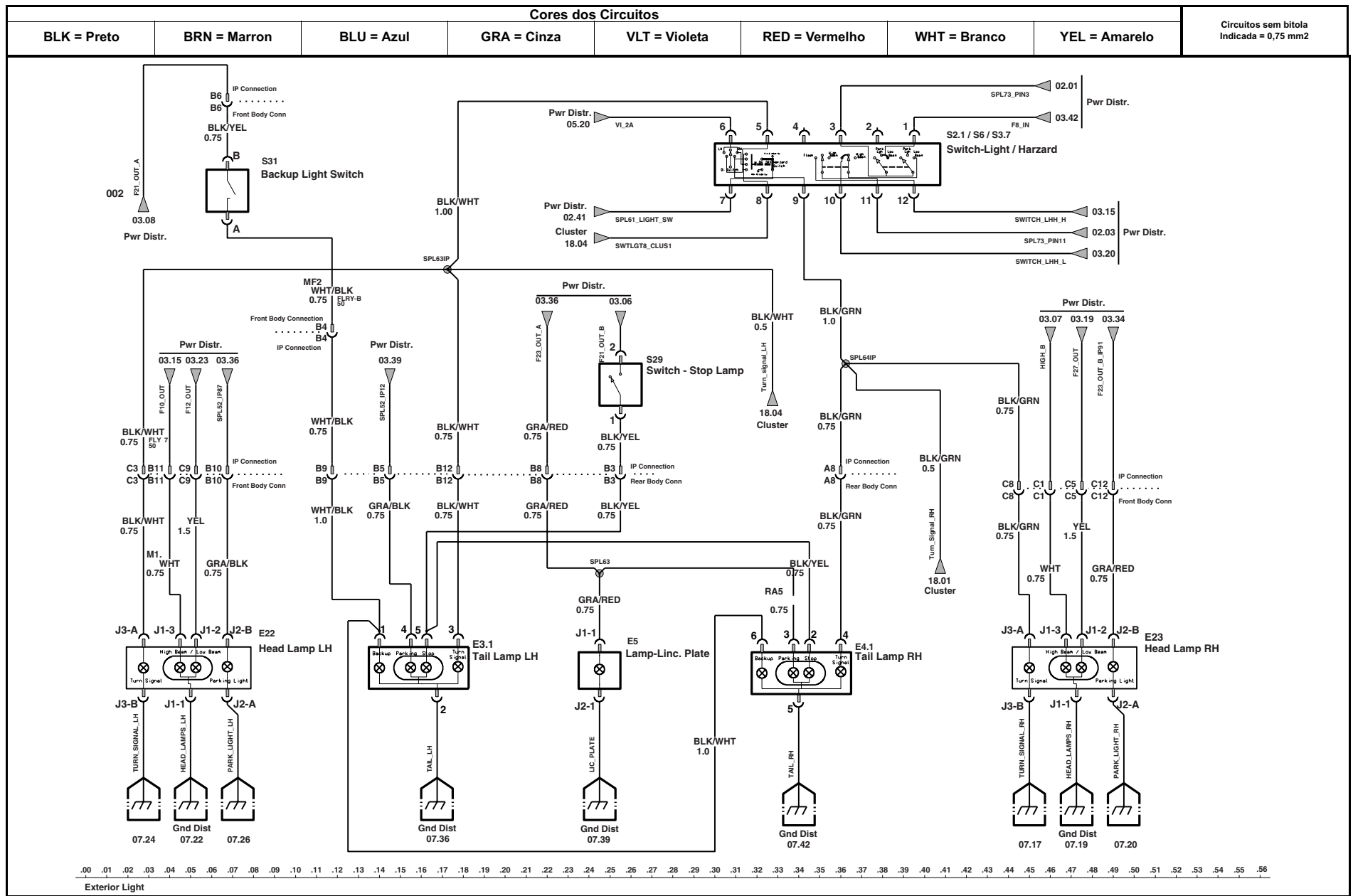

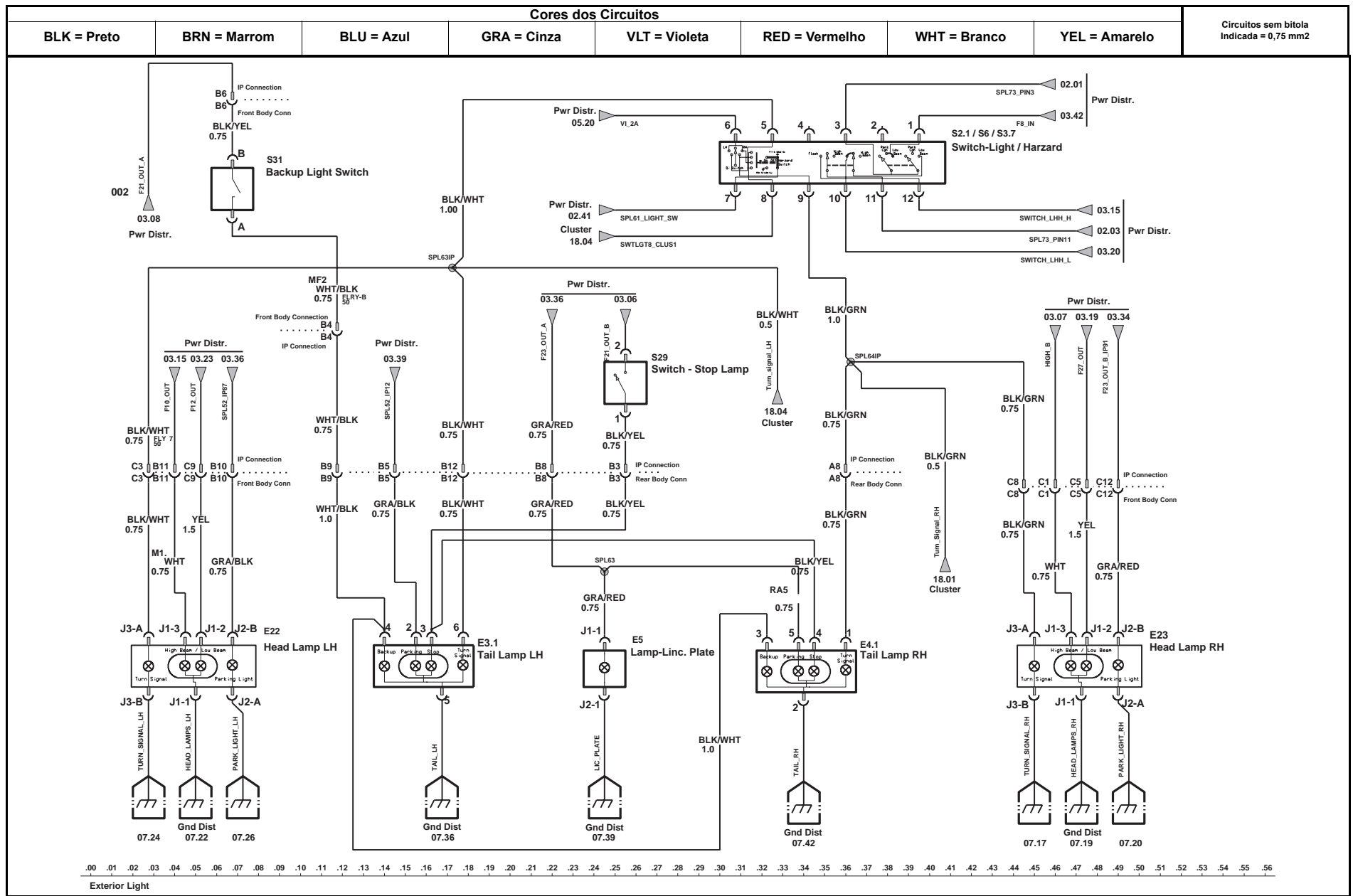

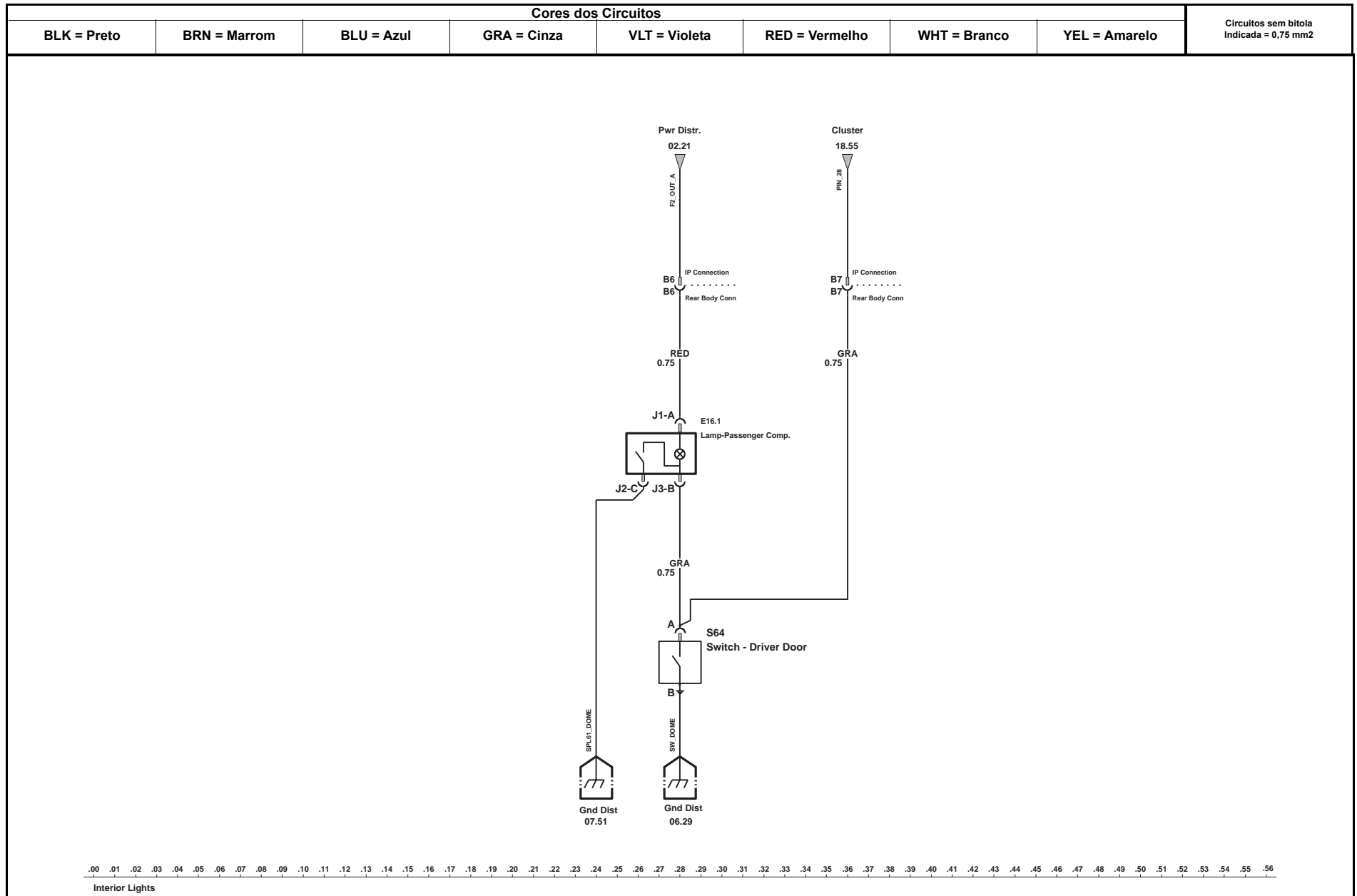

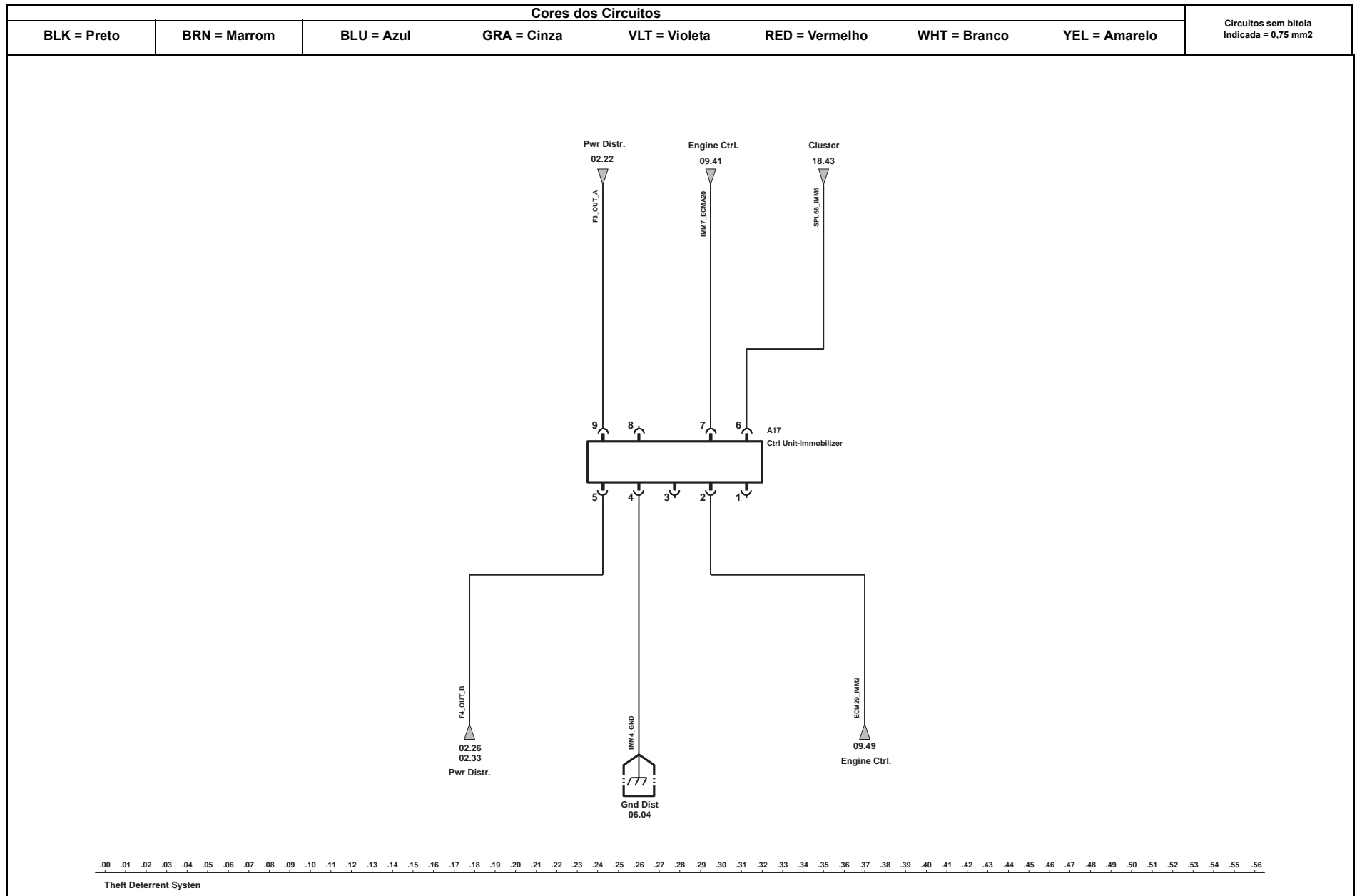

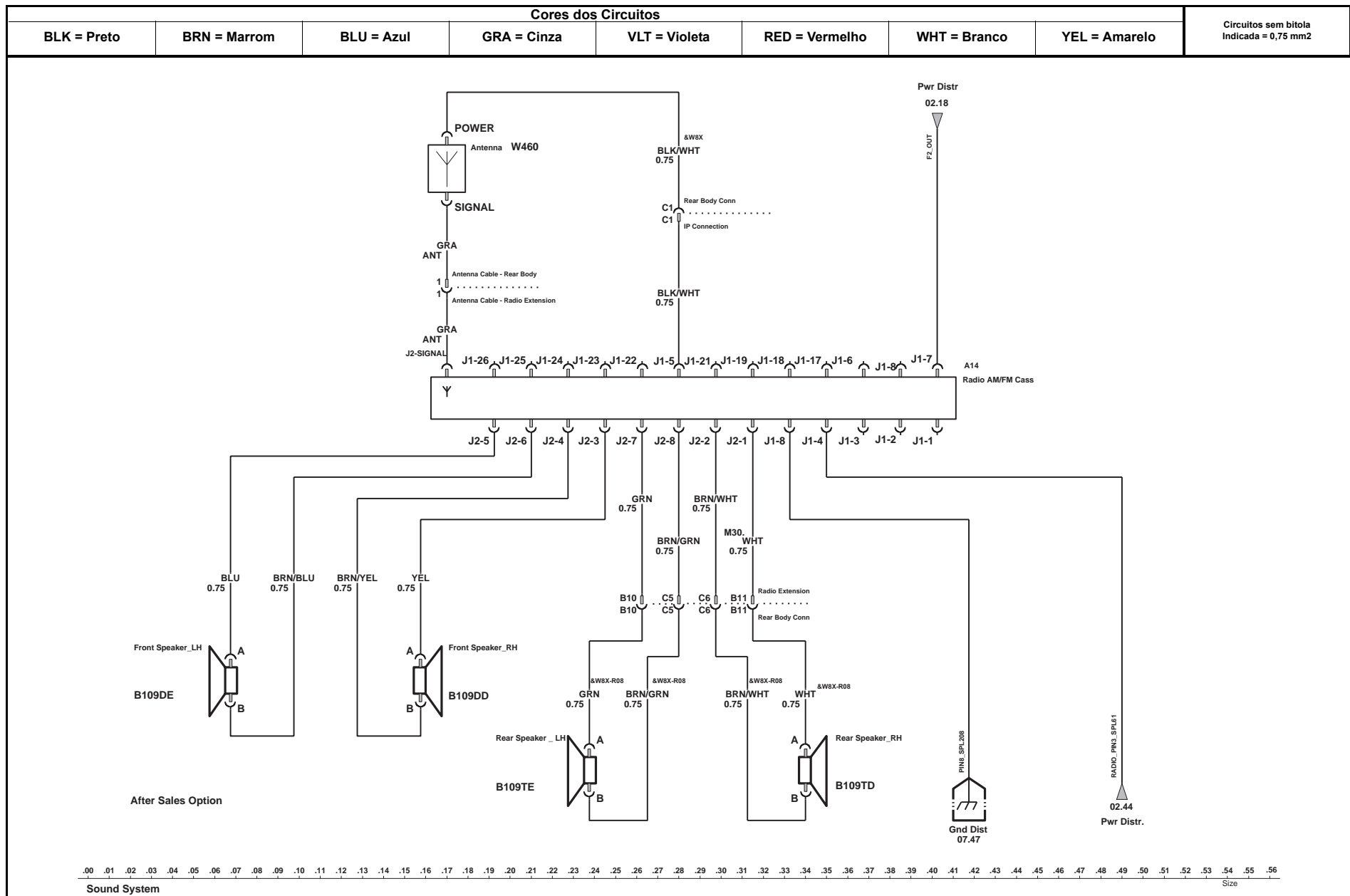

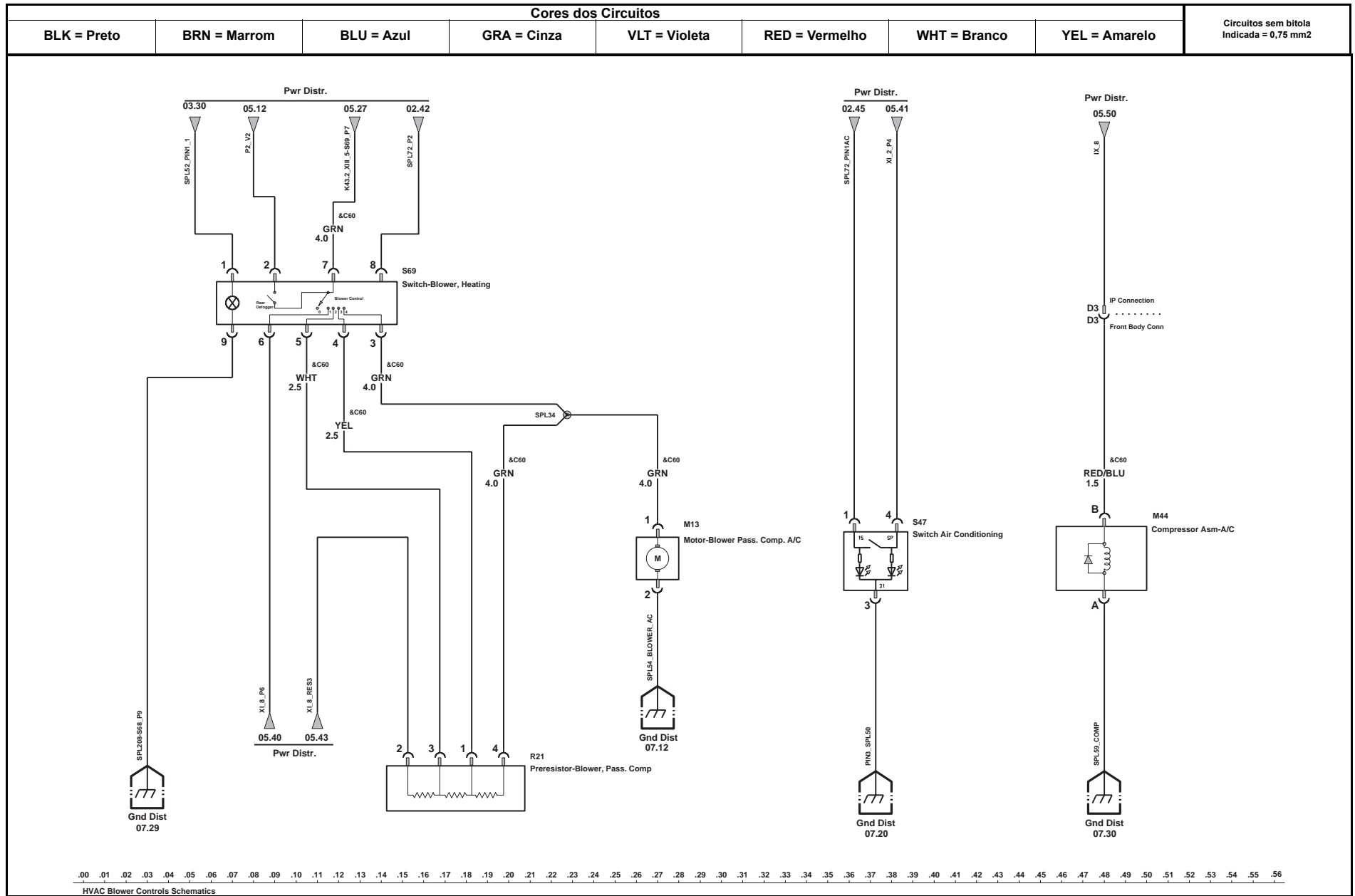

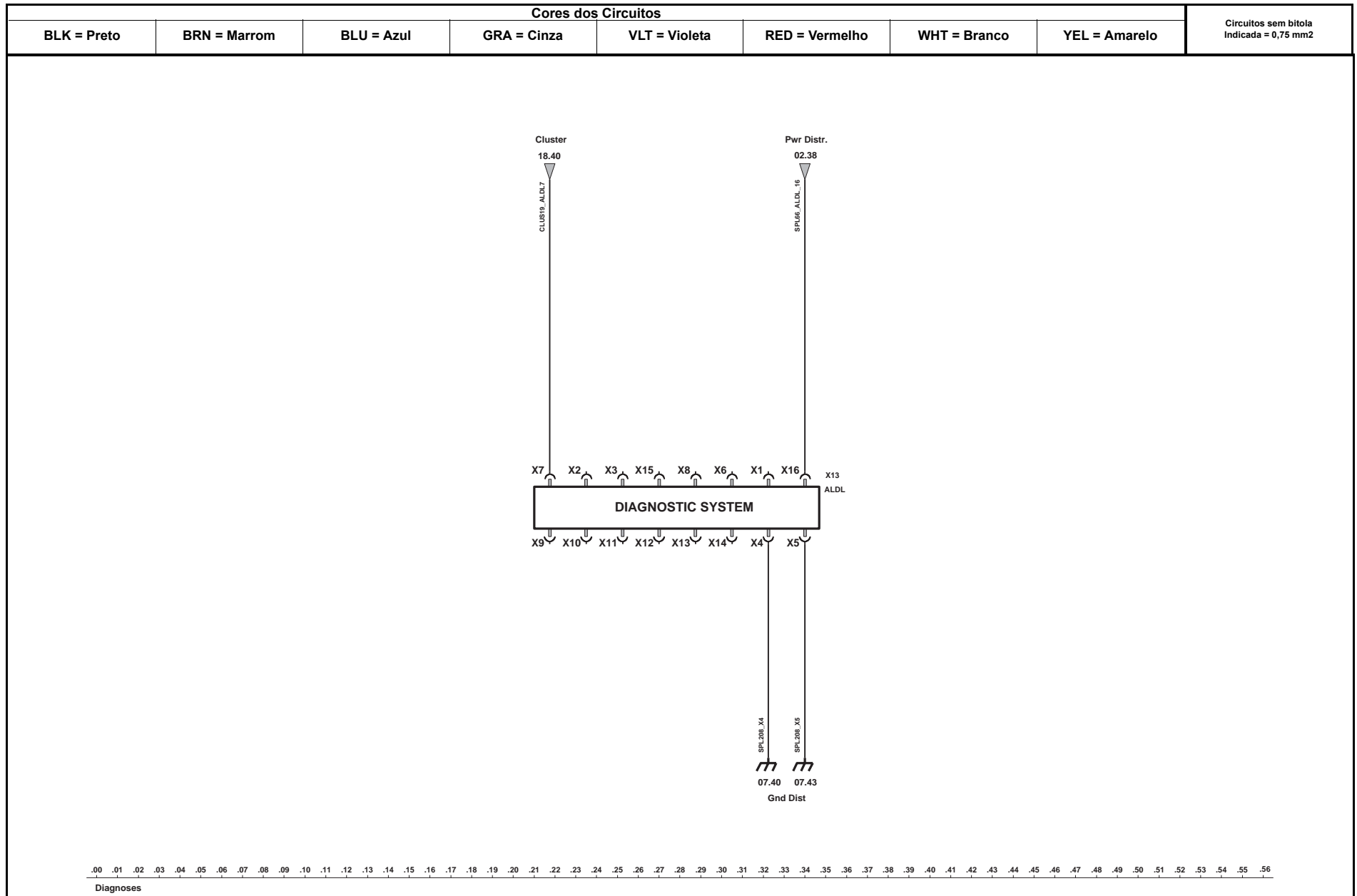

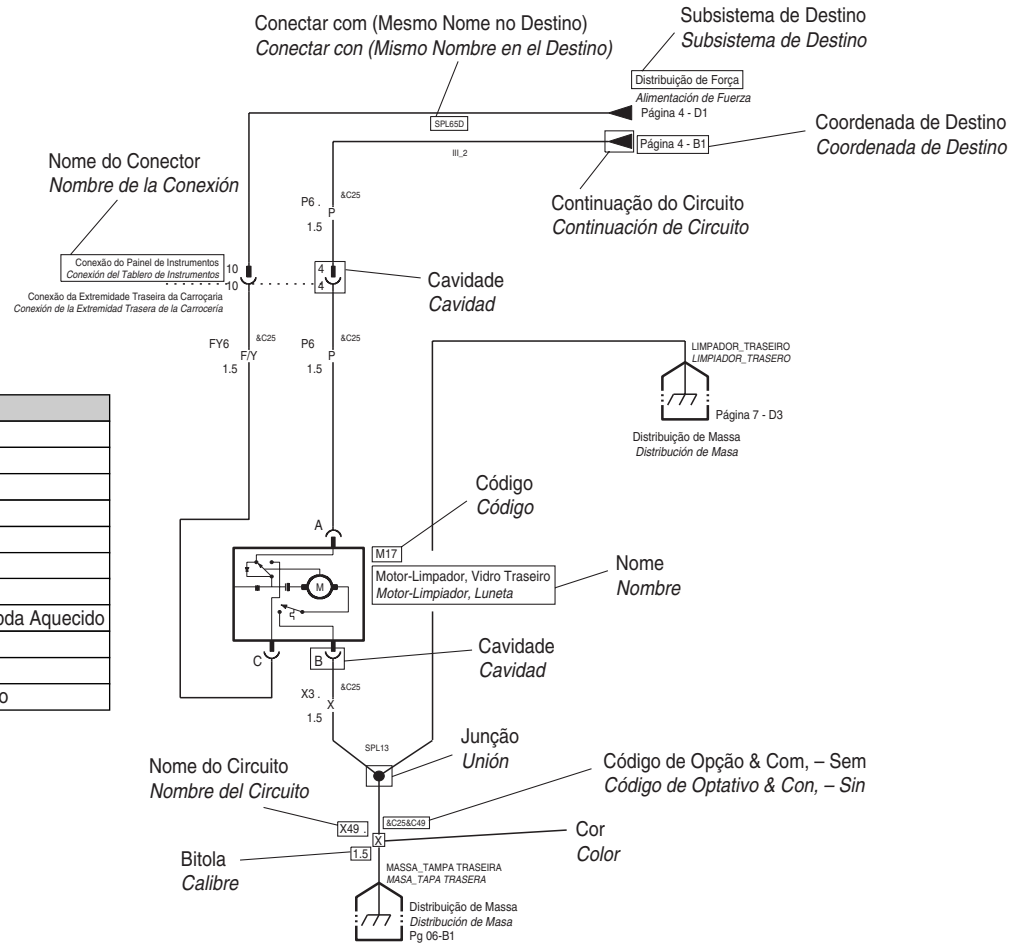

Códigos de Opção	
C25	Limpador do Vidro Traseiro
C49	Desembaçador do Vidro Traseiro
C60	Condicionador de Ar
CD4	Temporizador do Limpador de Pára-brisa
W8X	Previsão para Instalação de Rádio
U16	Tacômetro
LNL	Motor 1.0 Flex
NF2	Motor VHC 1.0 Gasolina Com Sensor Lambda Aquecido
L19	Motor VHC 1.0 Gasolina
L11	Motor VHC 1.0 Gasolina Exportação
LQS	Motor VHC 1.4 Gasolina, Local / Exportação



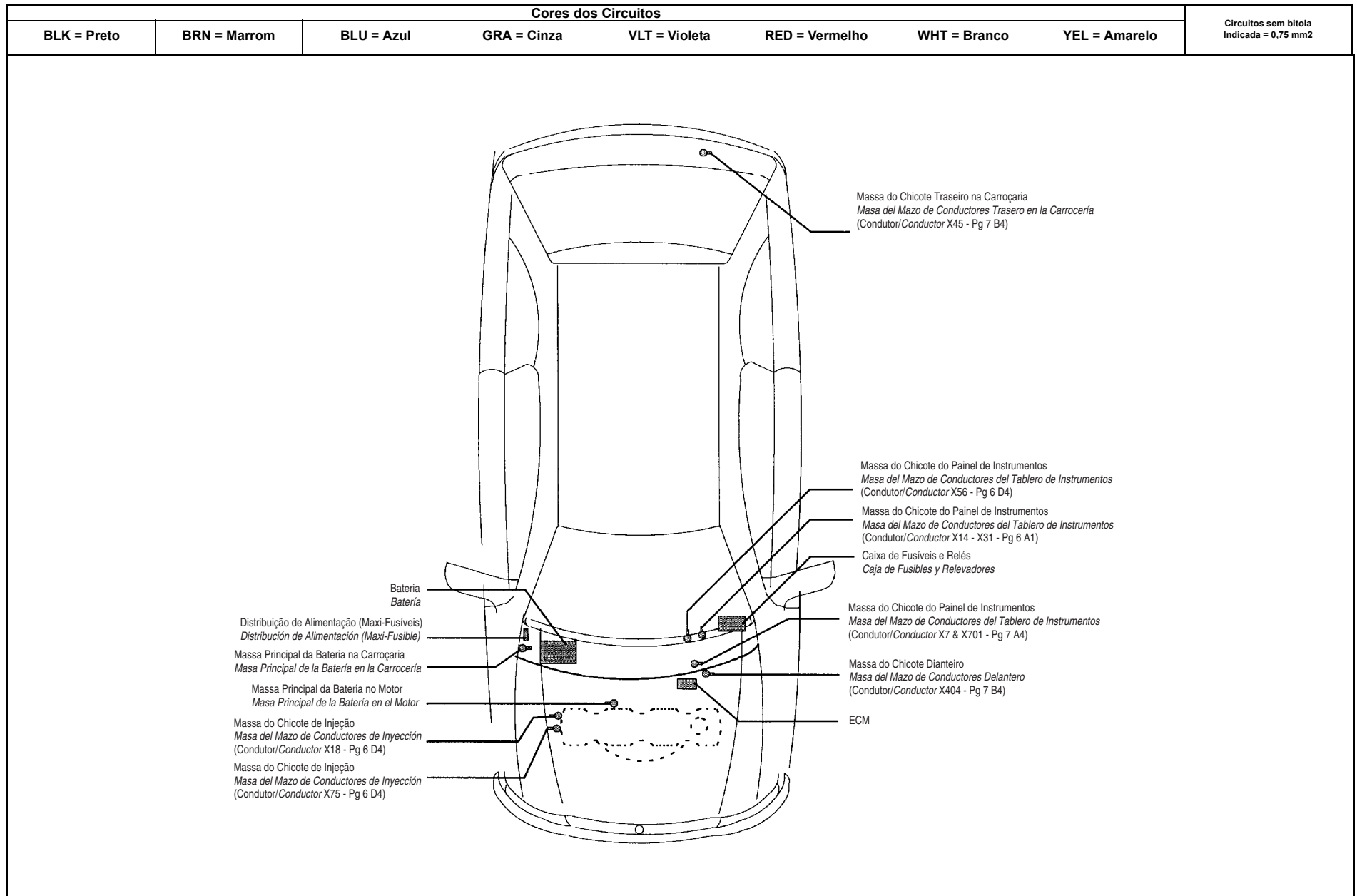

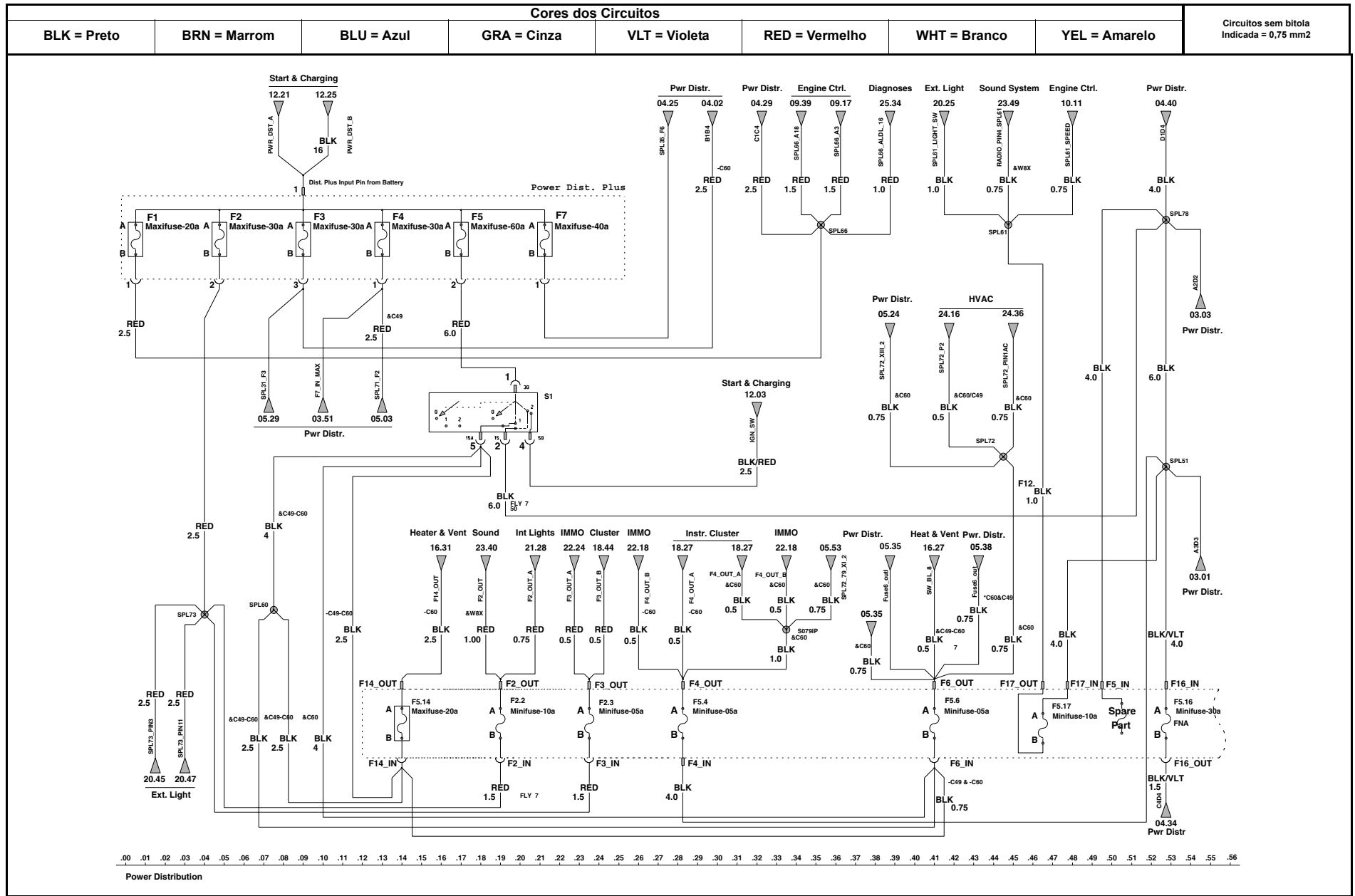

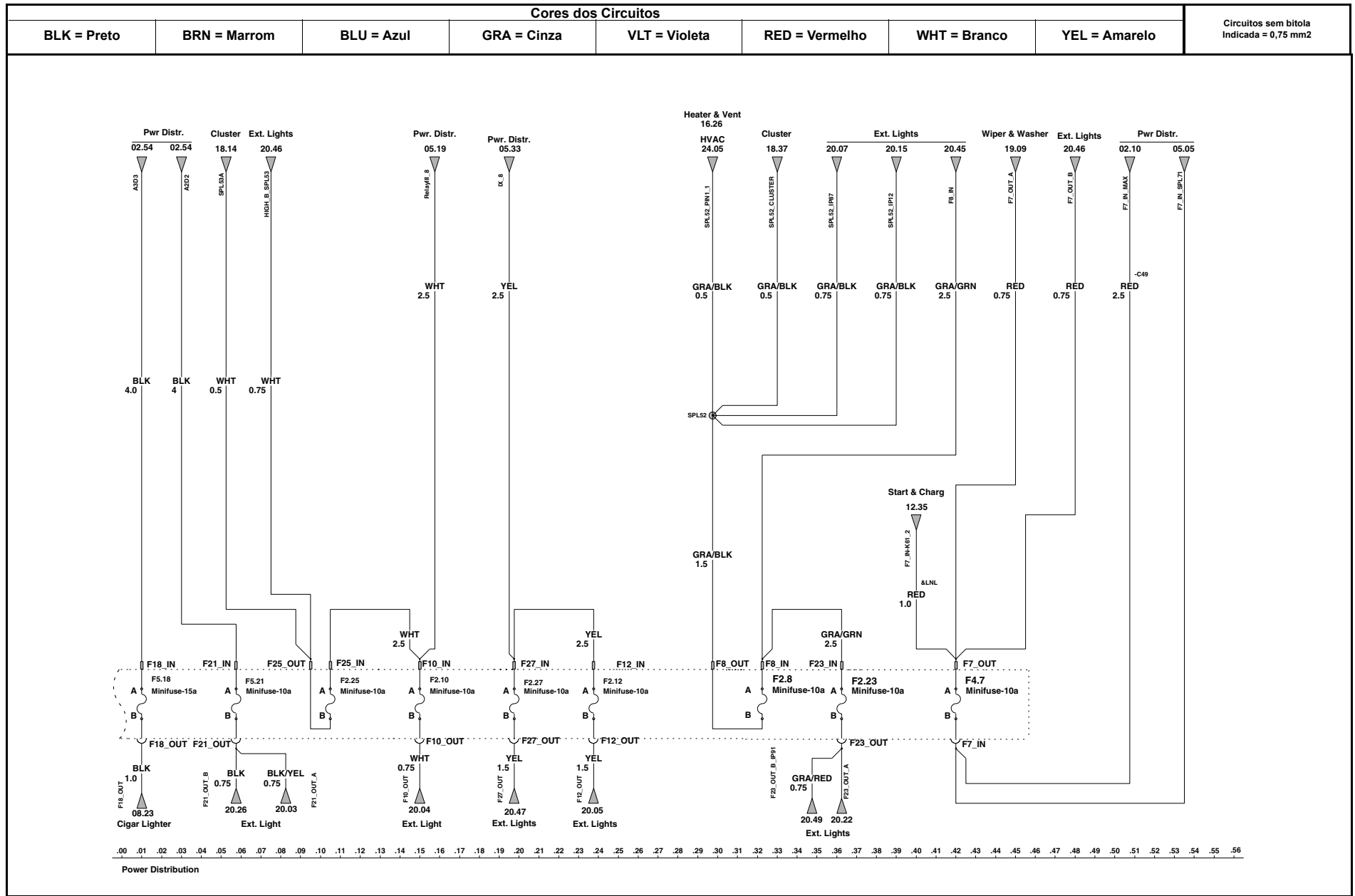

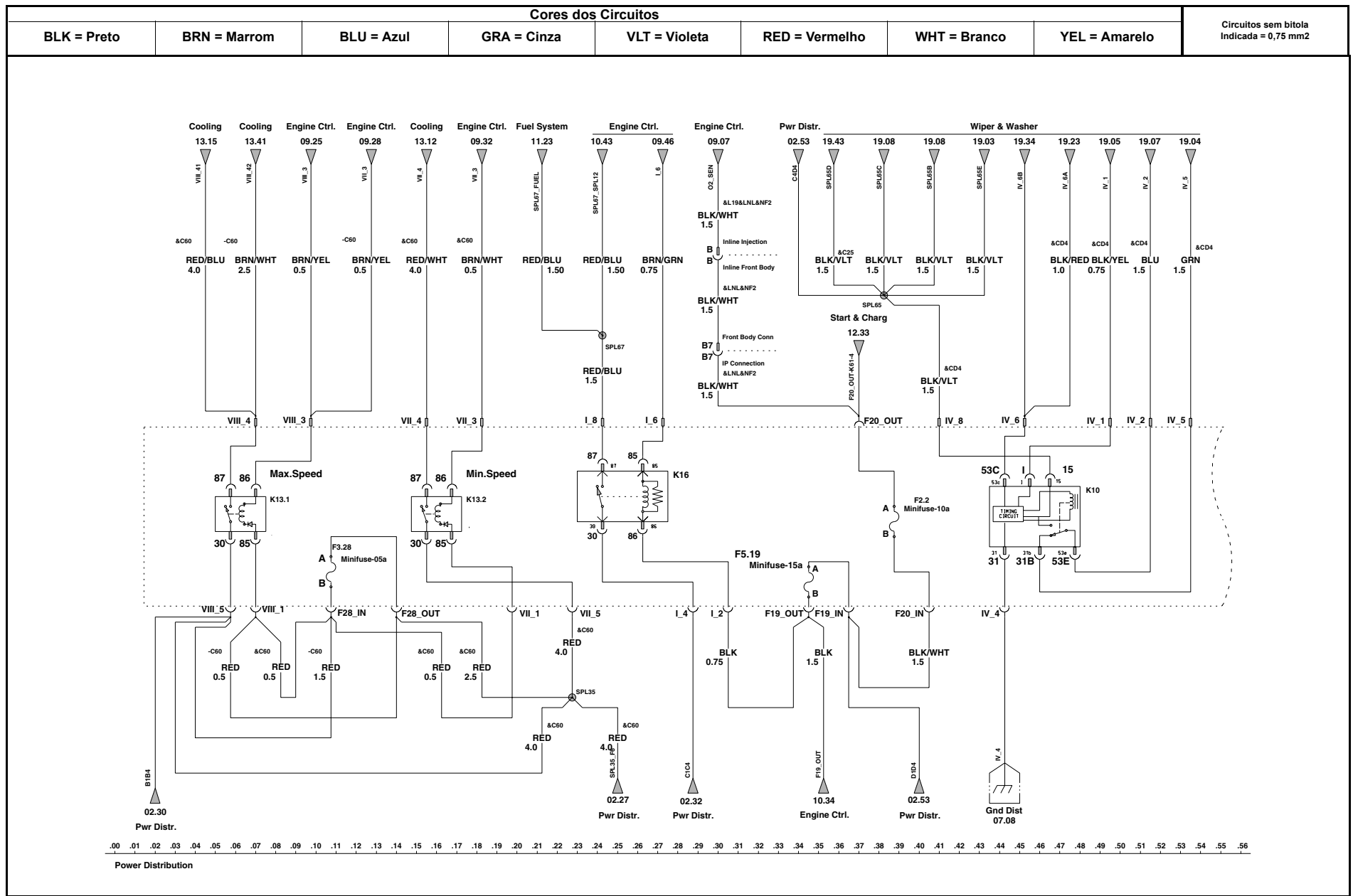

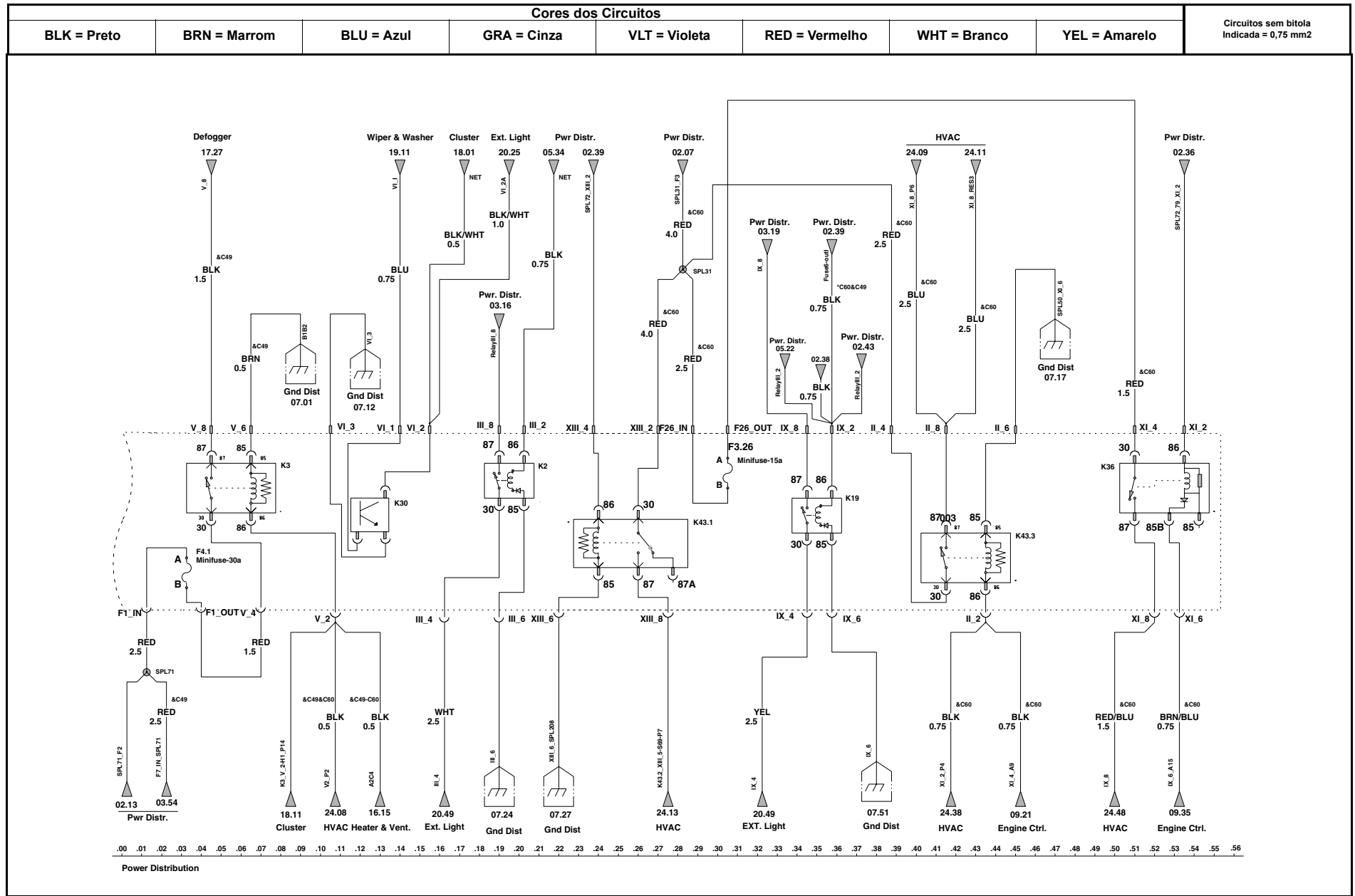

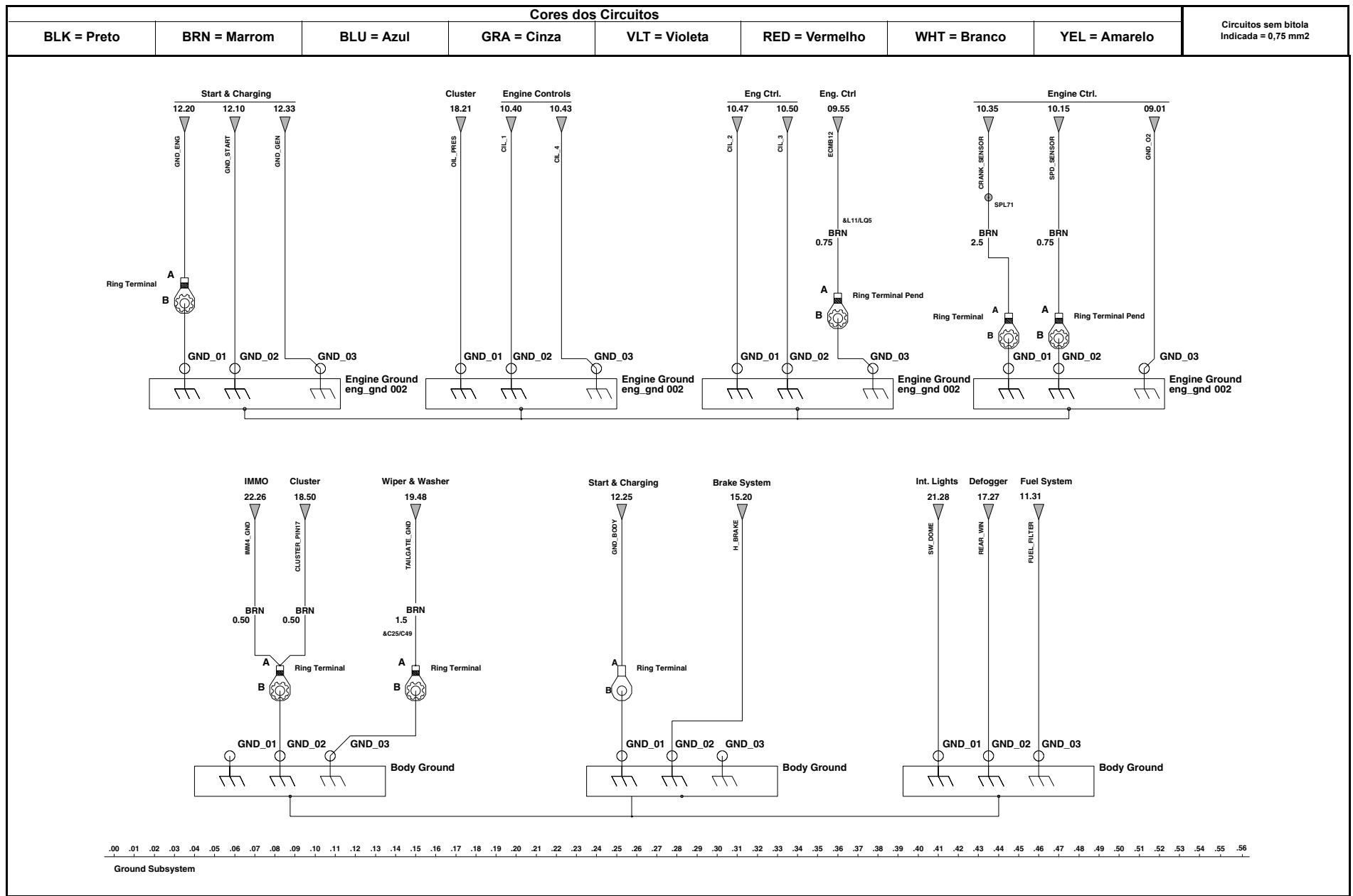

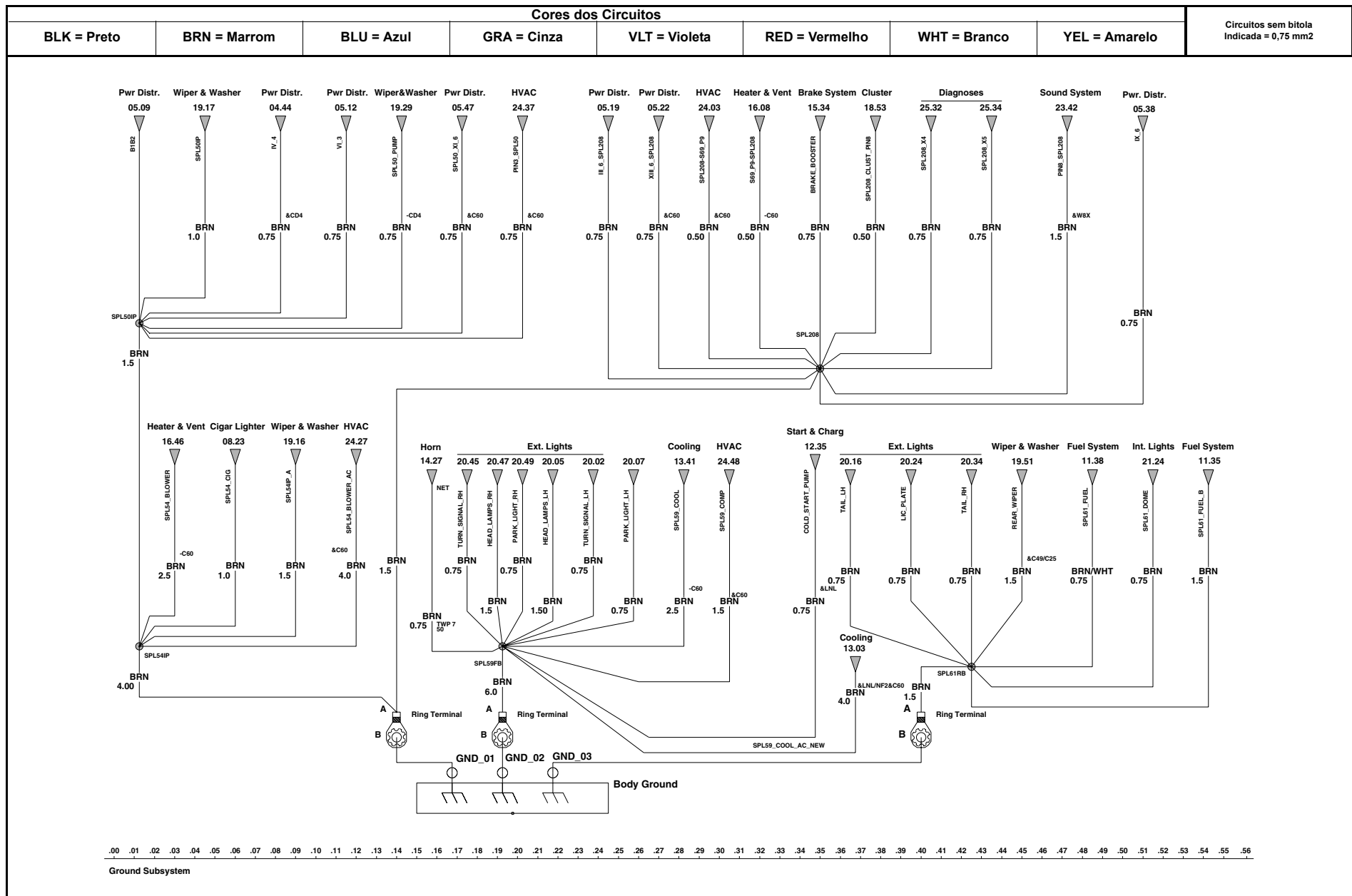

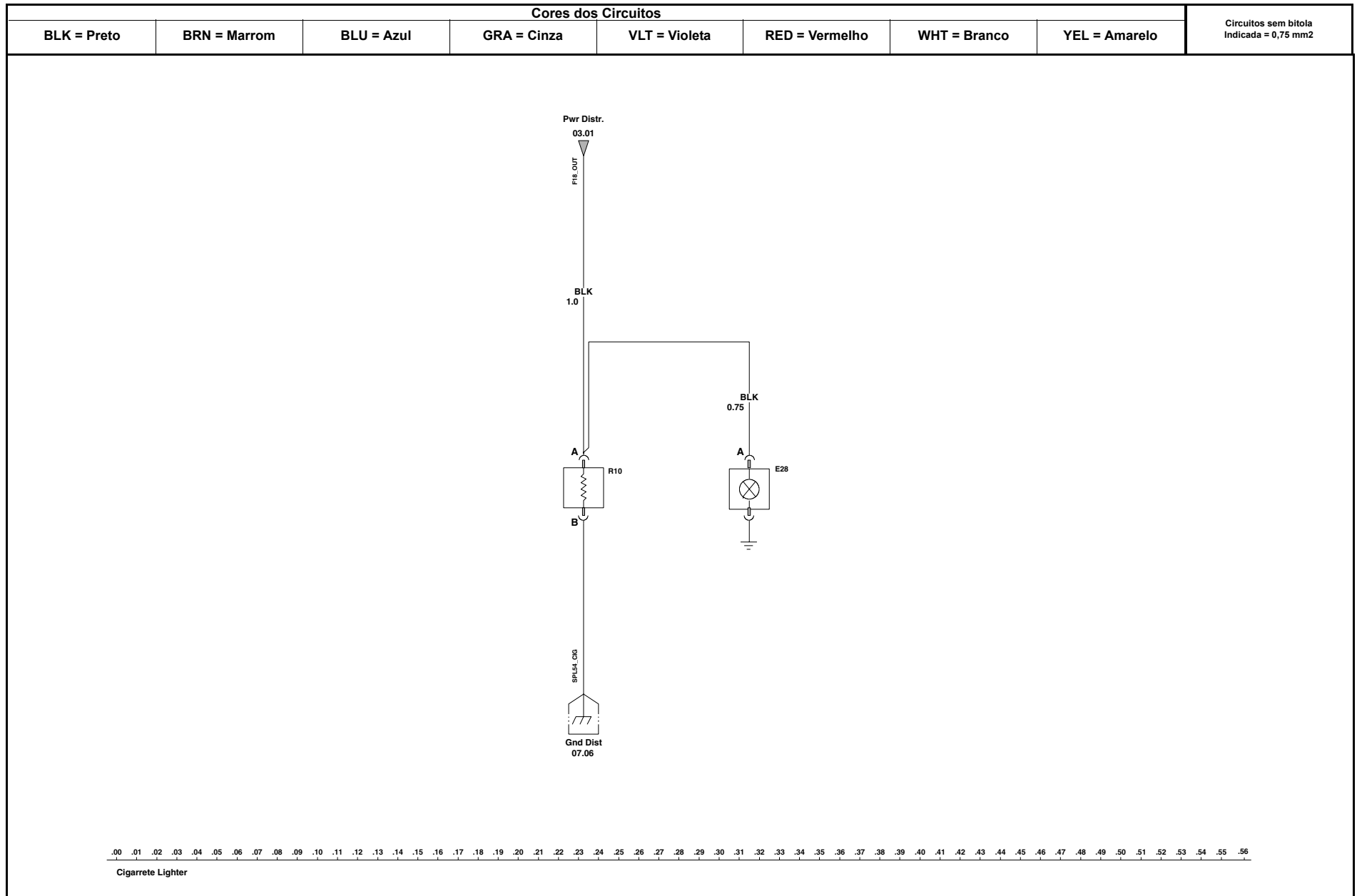

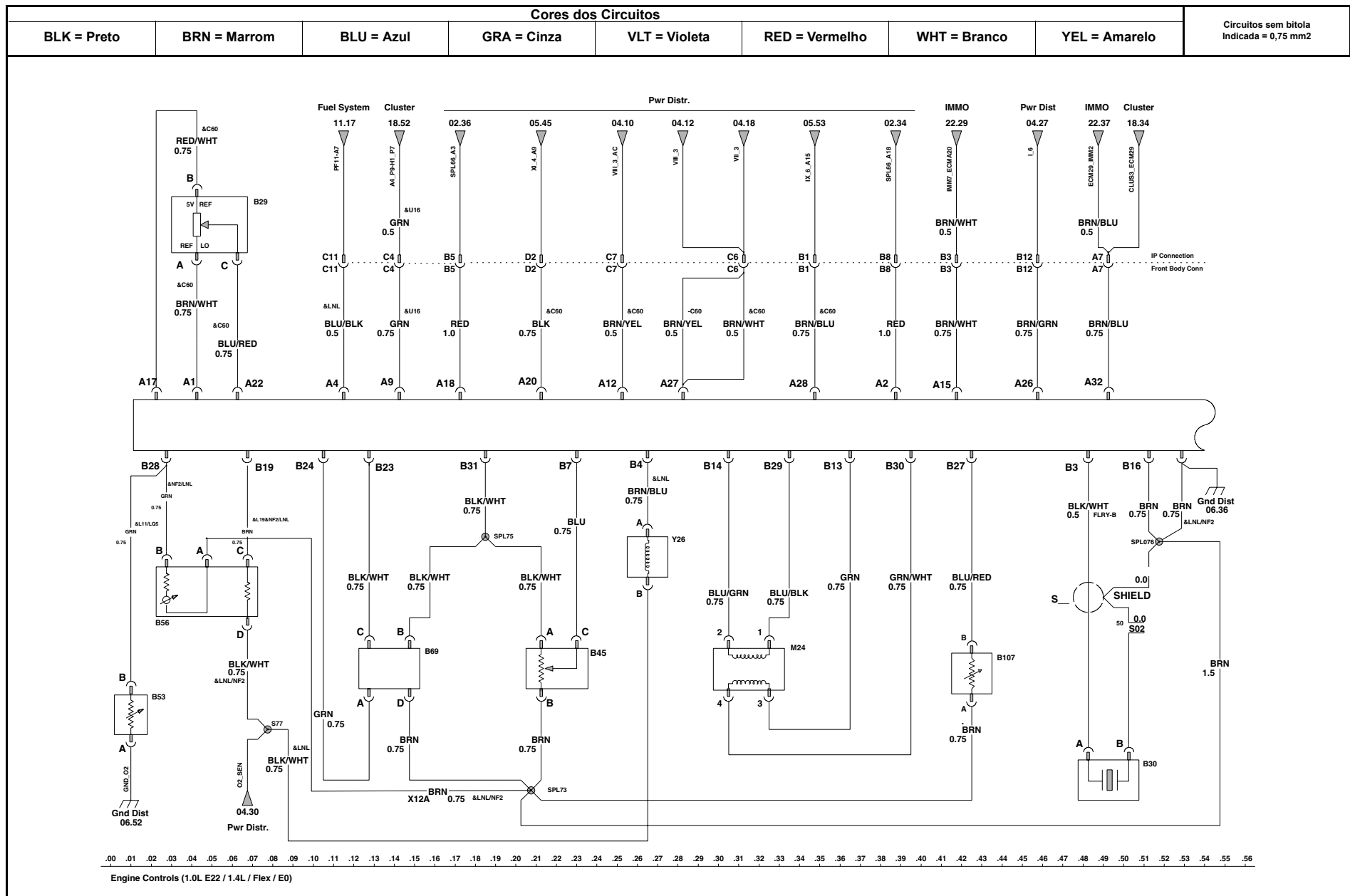

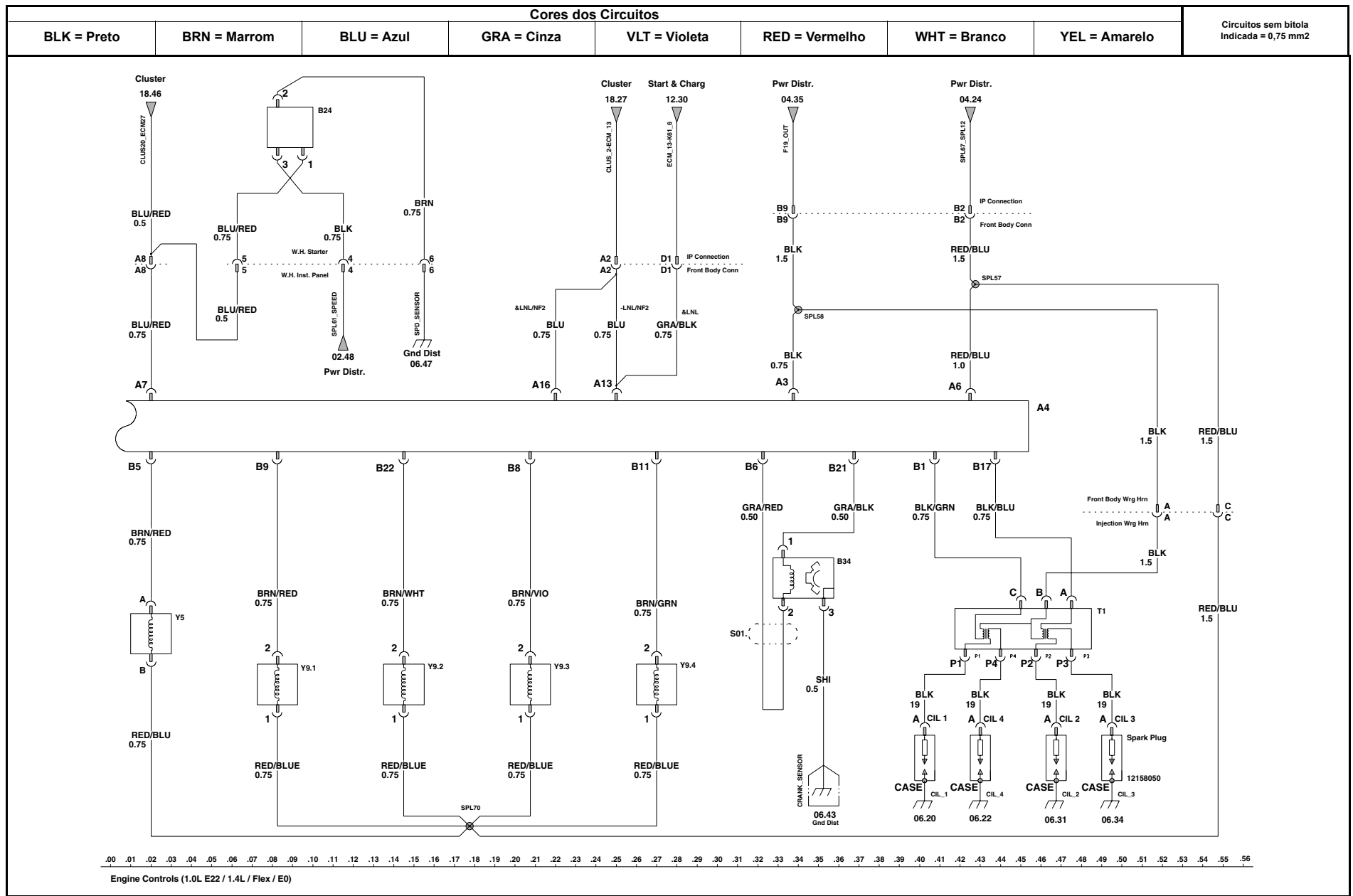

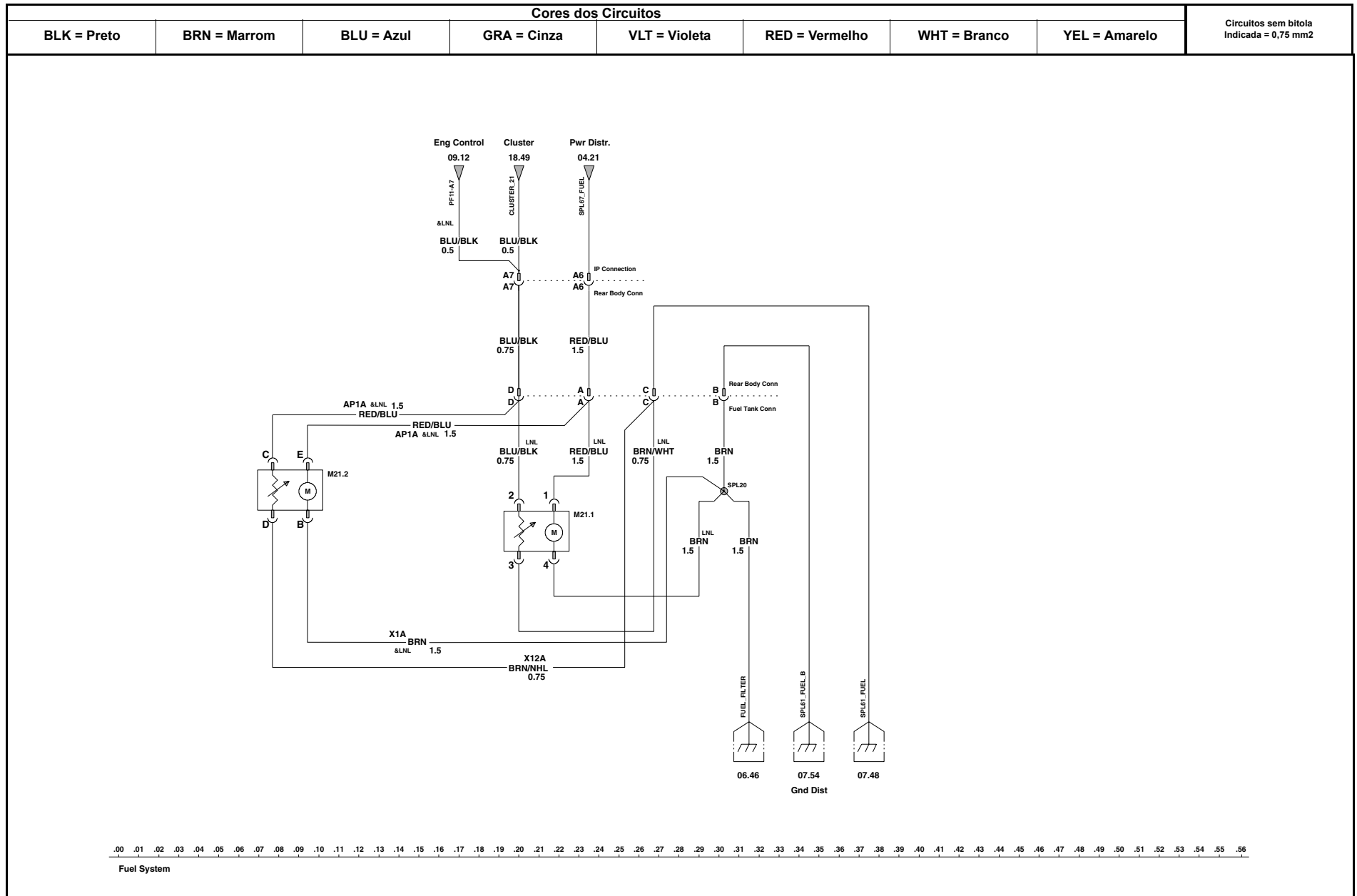

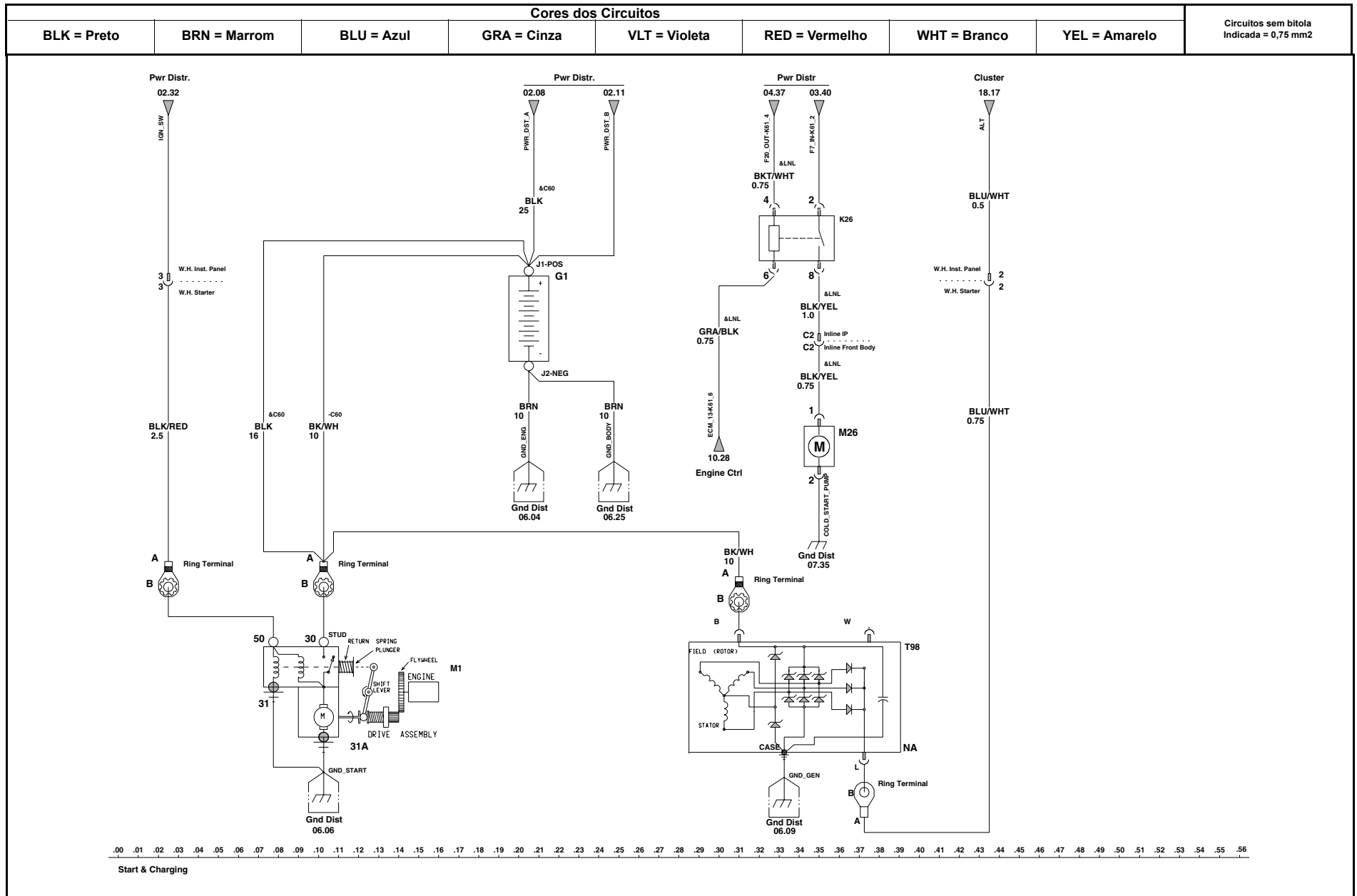

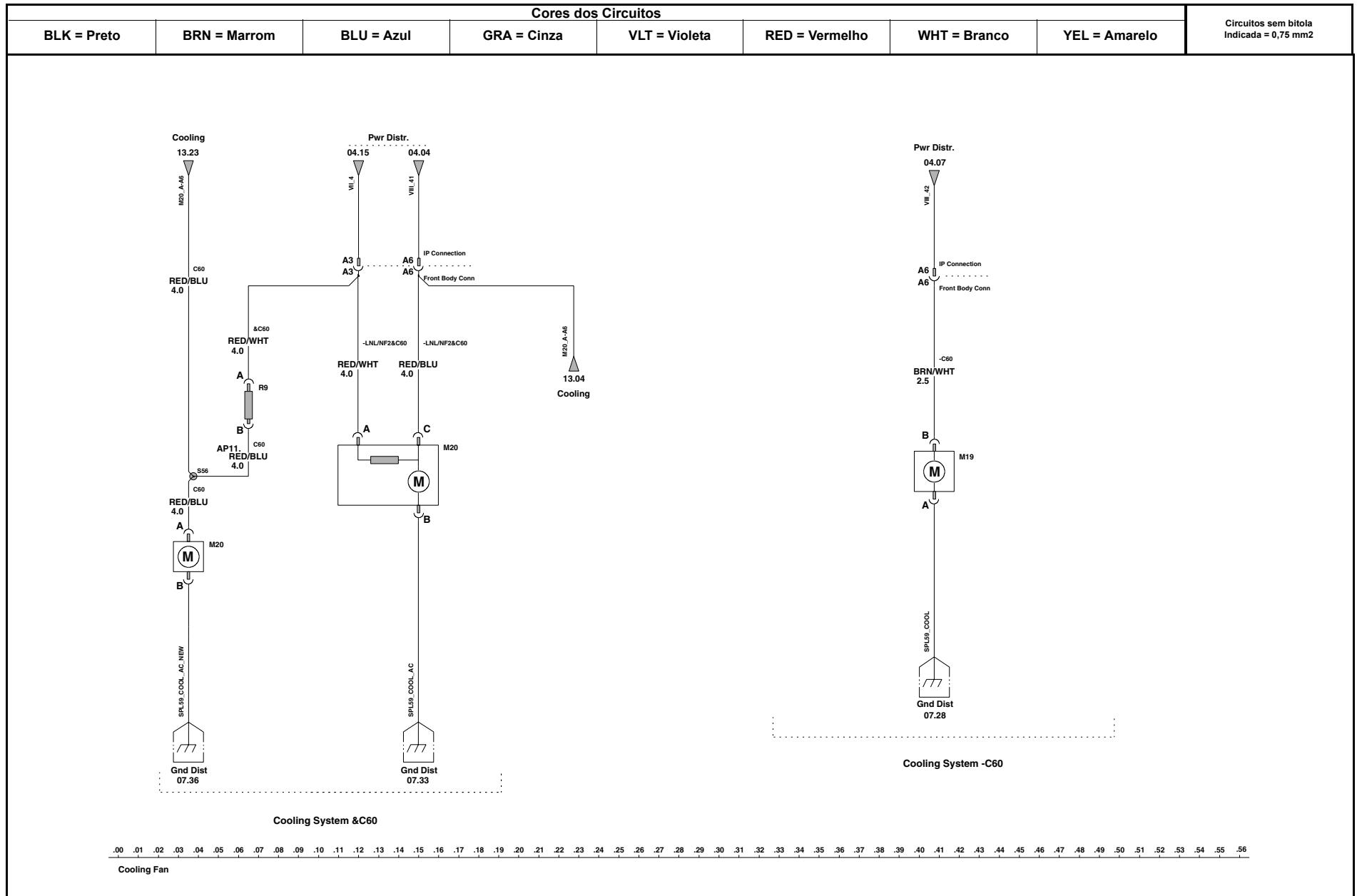

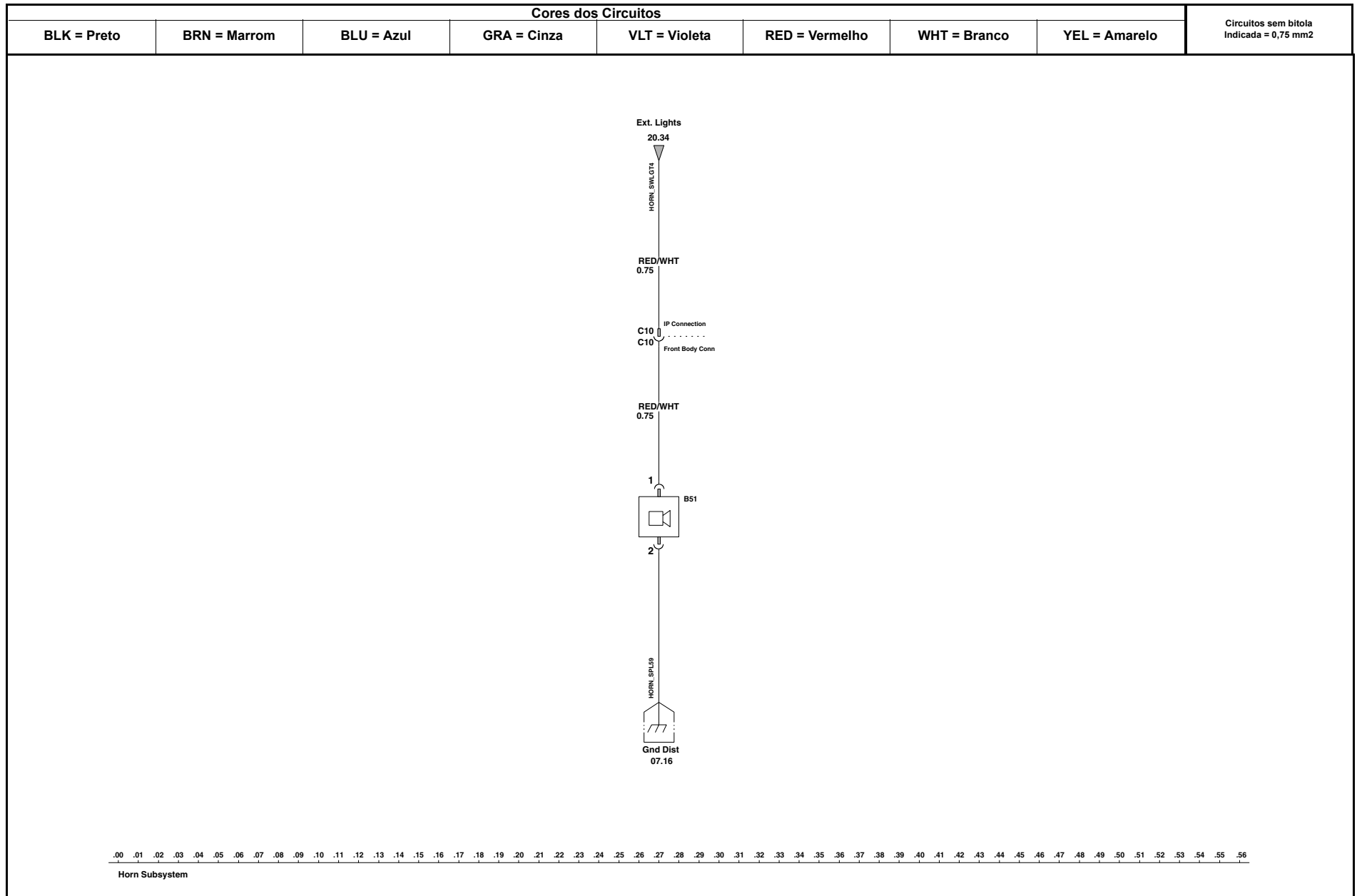

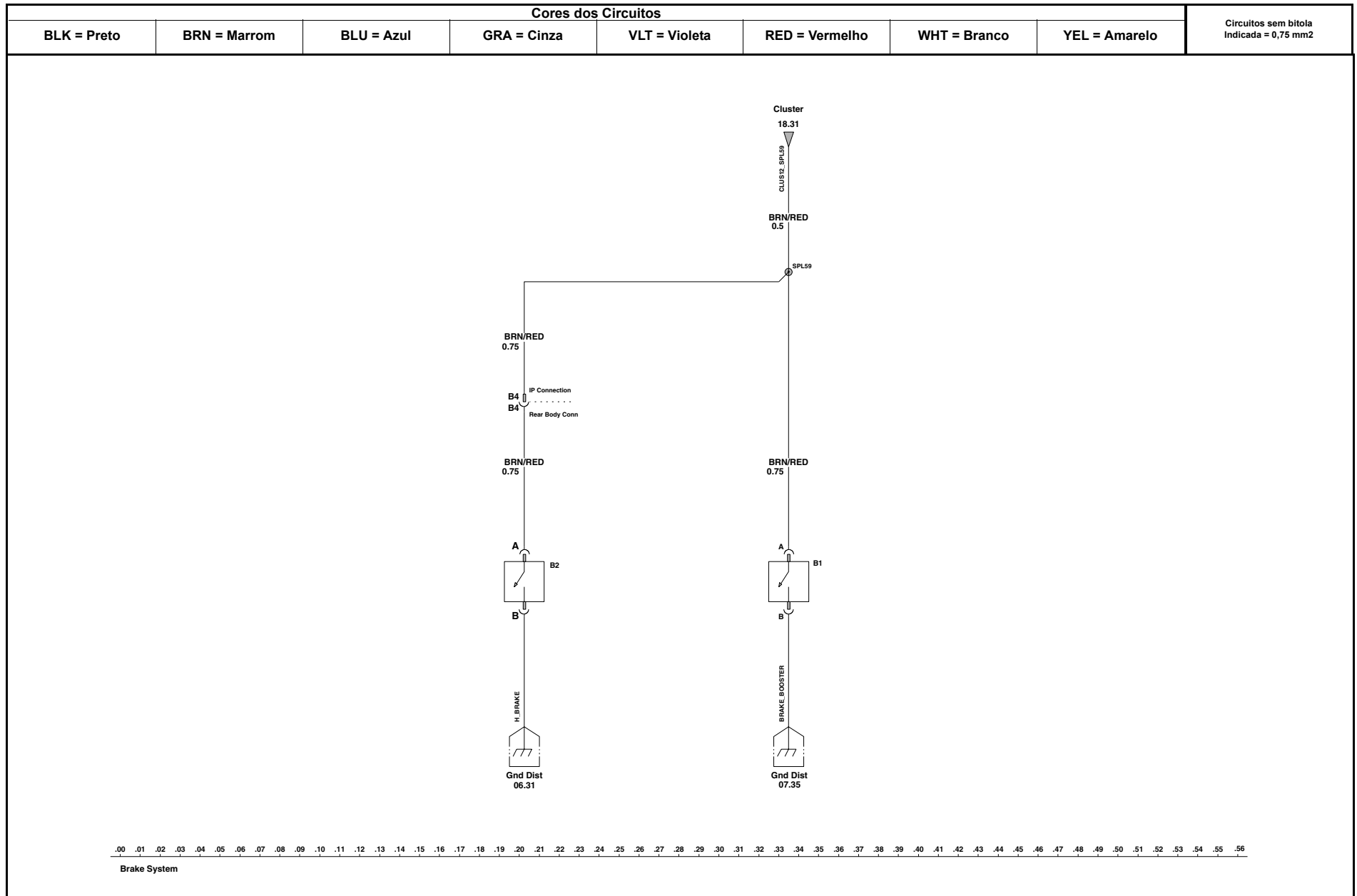

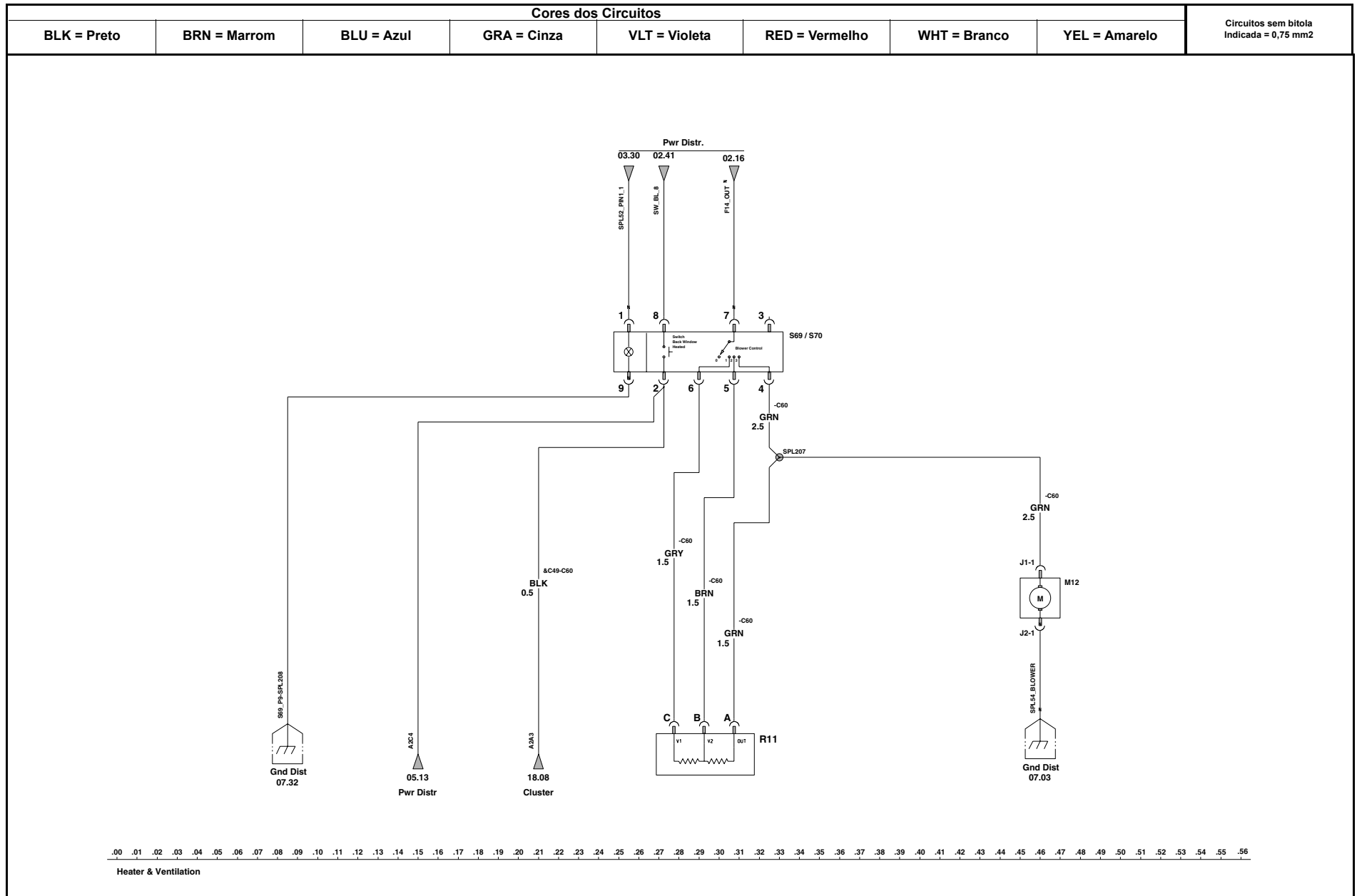

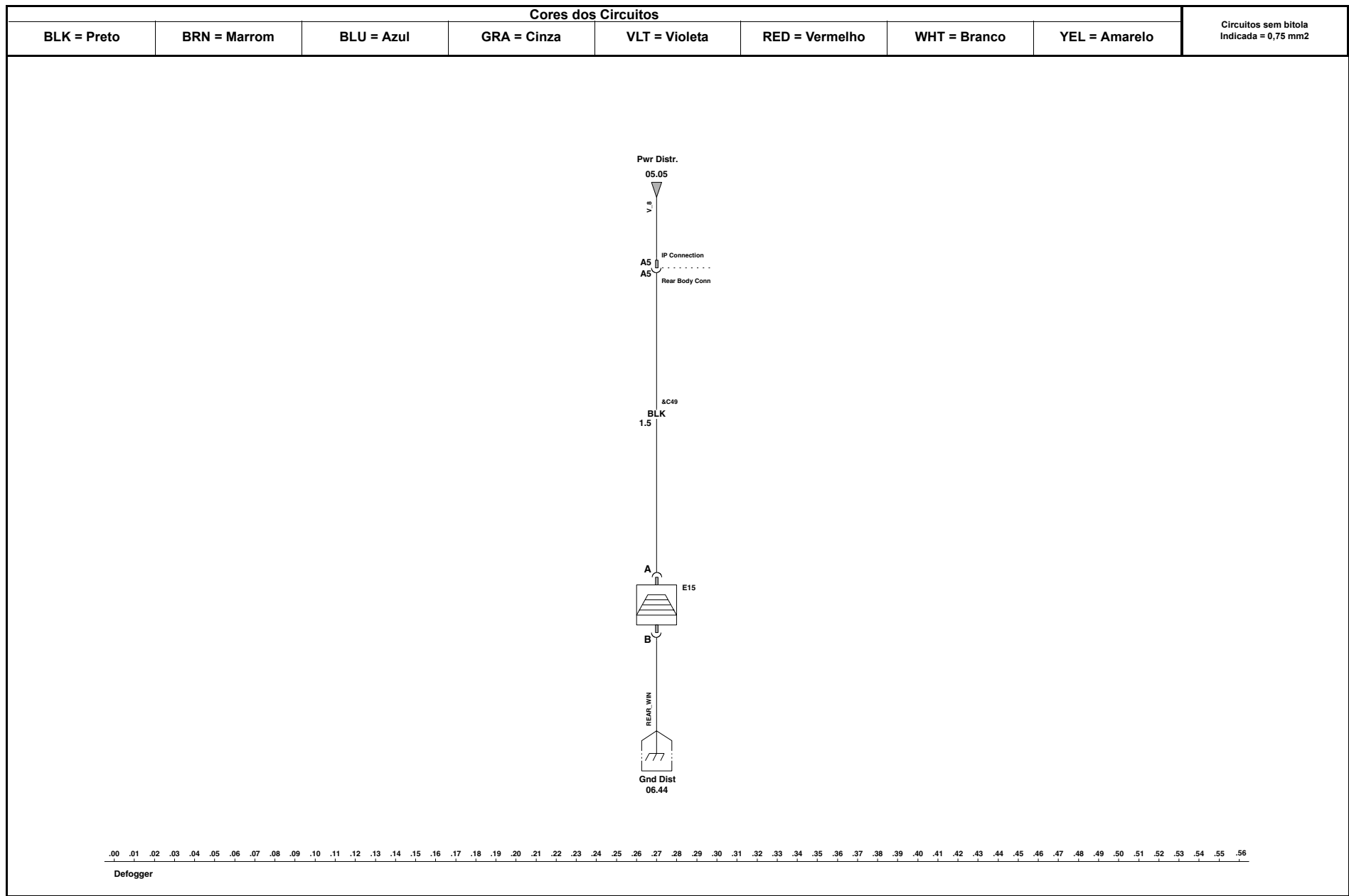

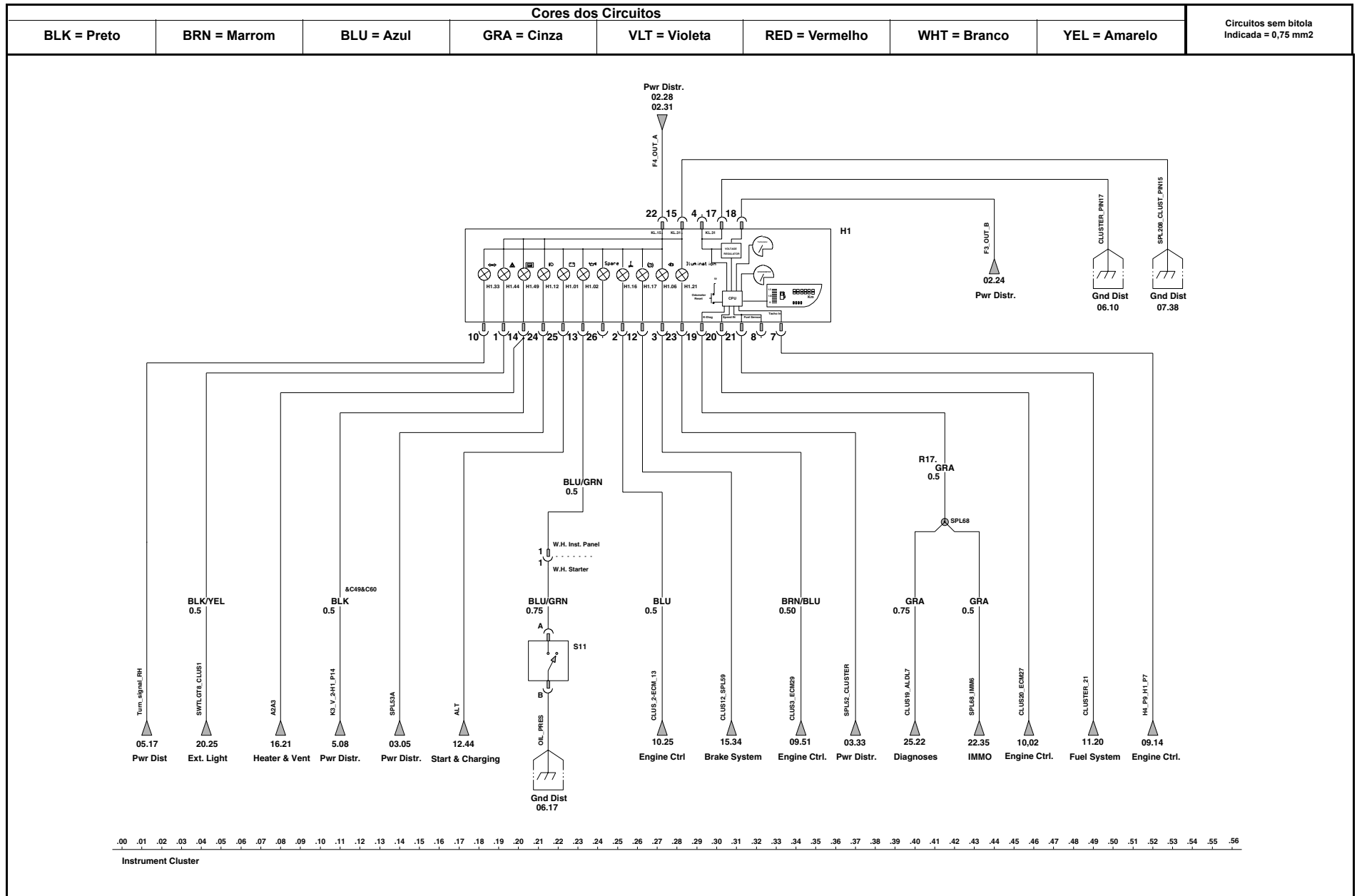

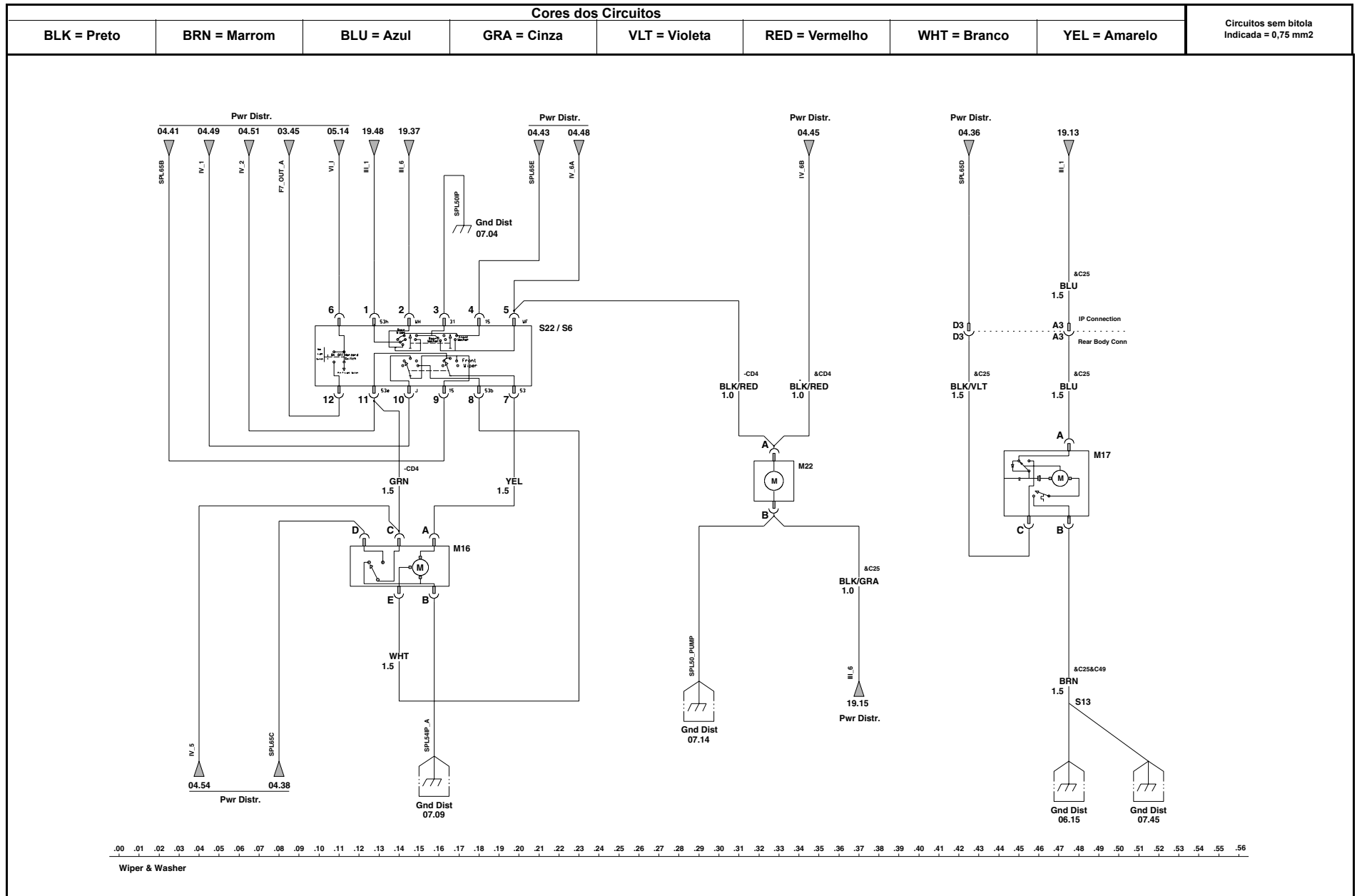

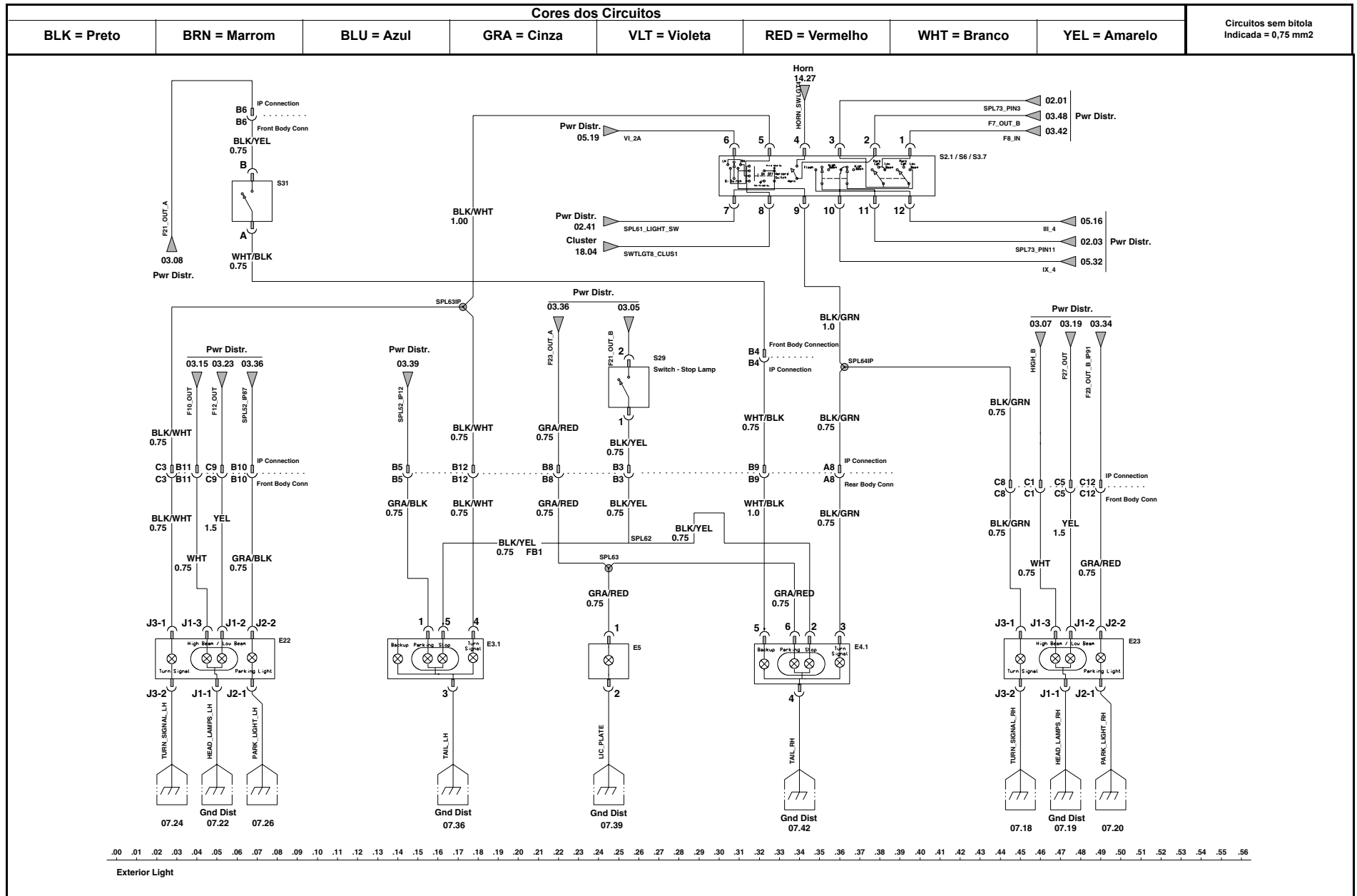

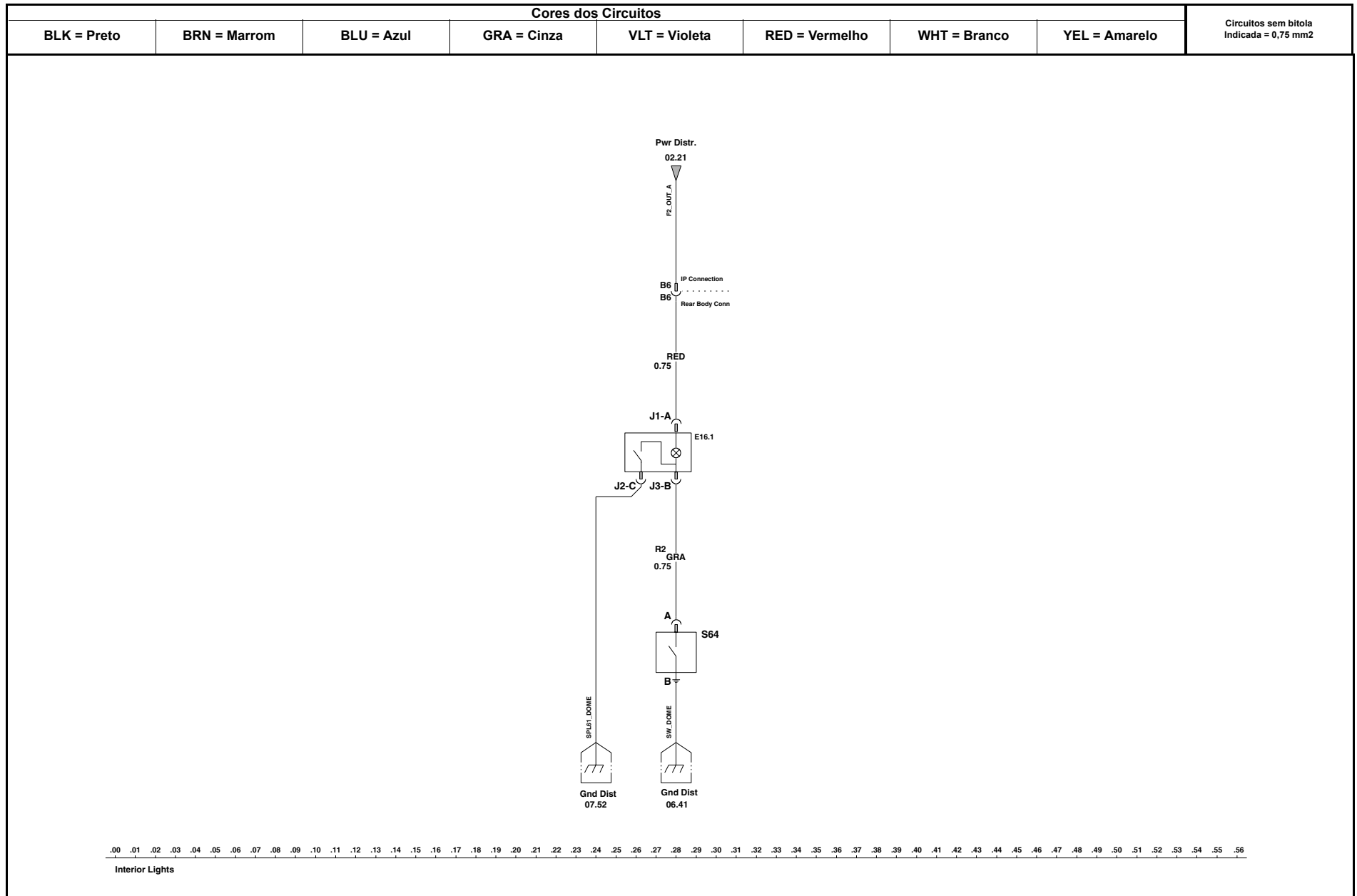

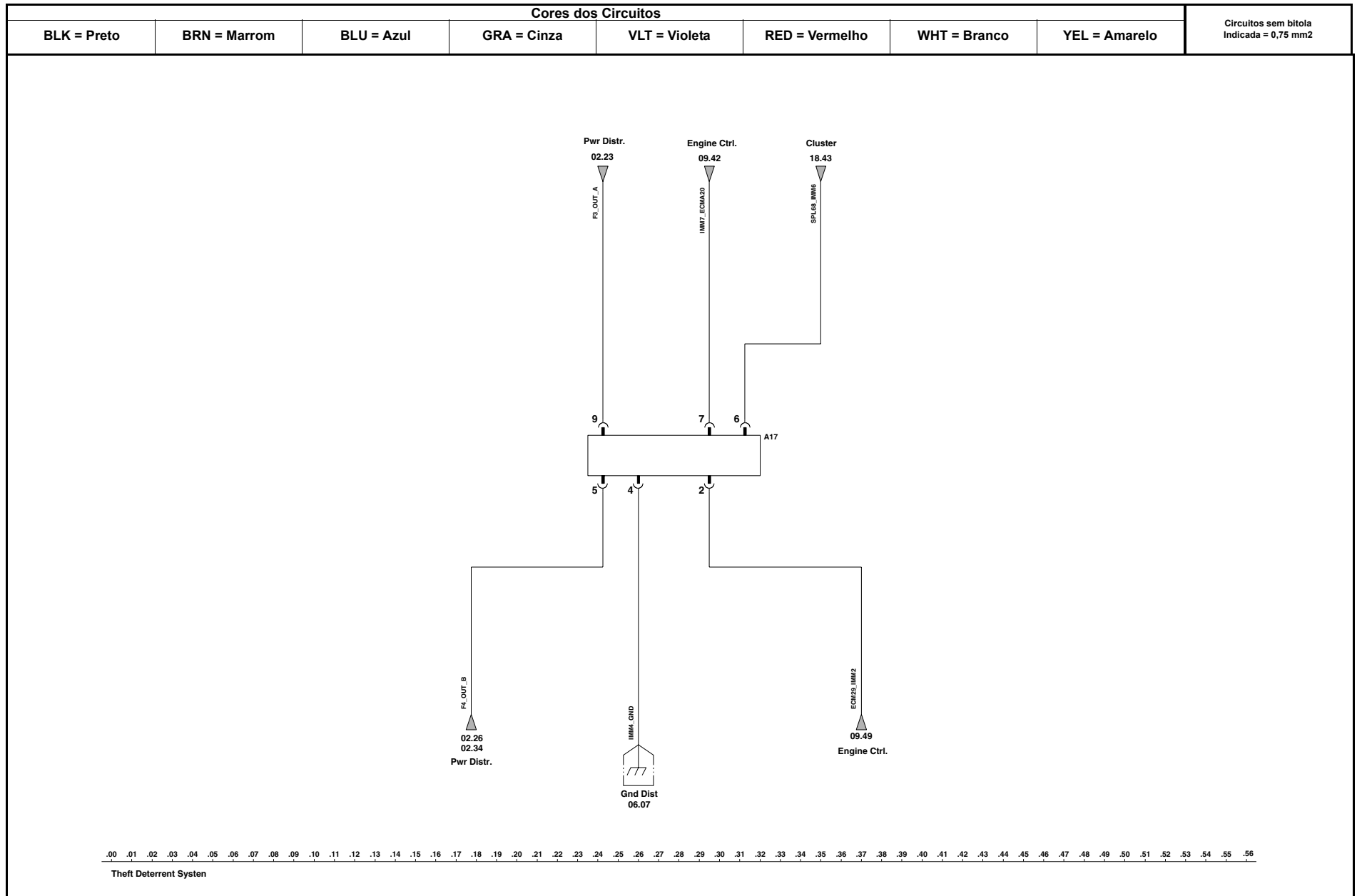

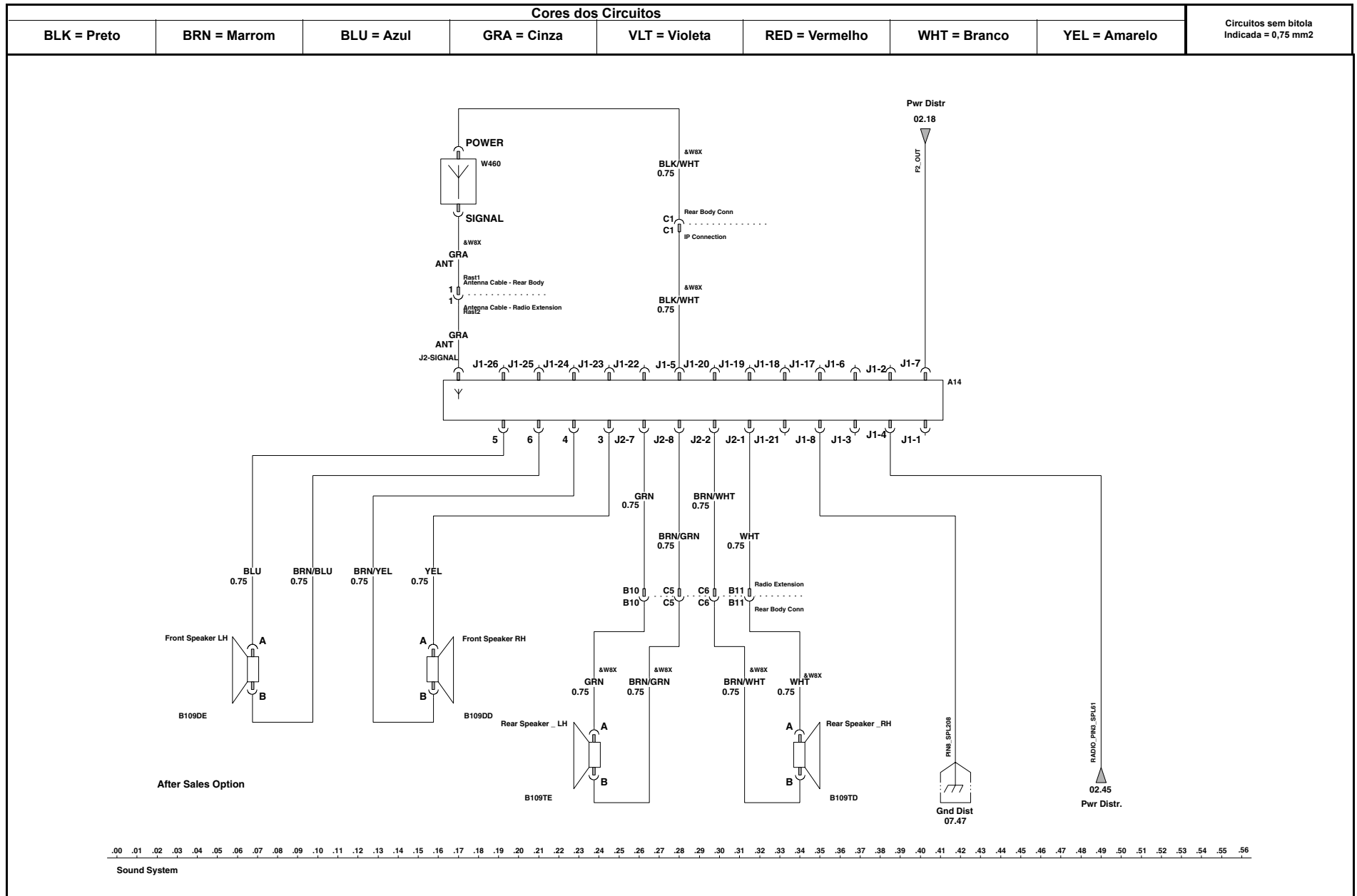

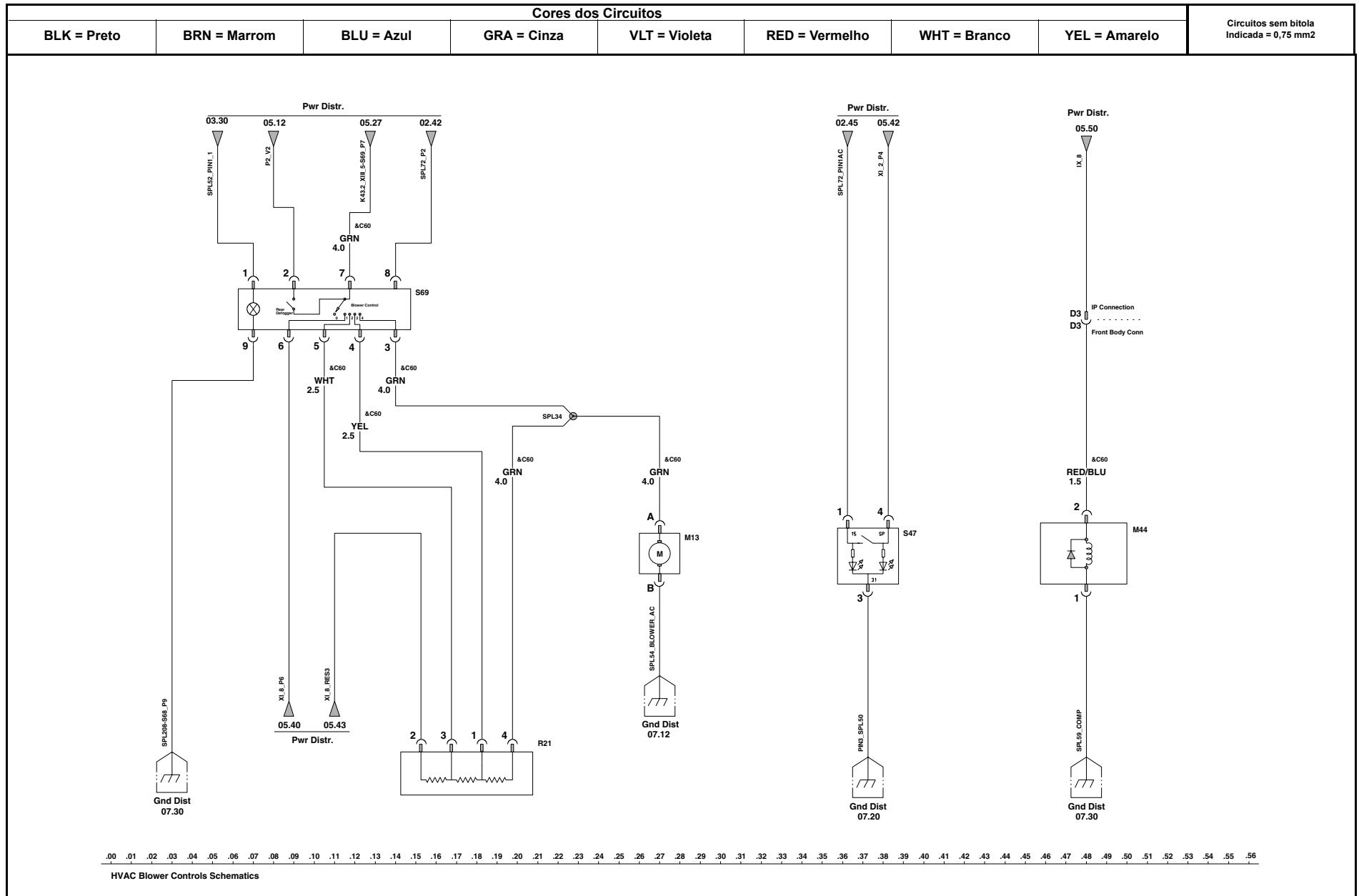

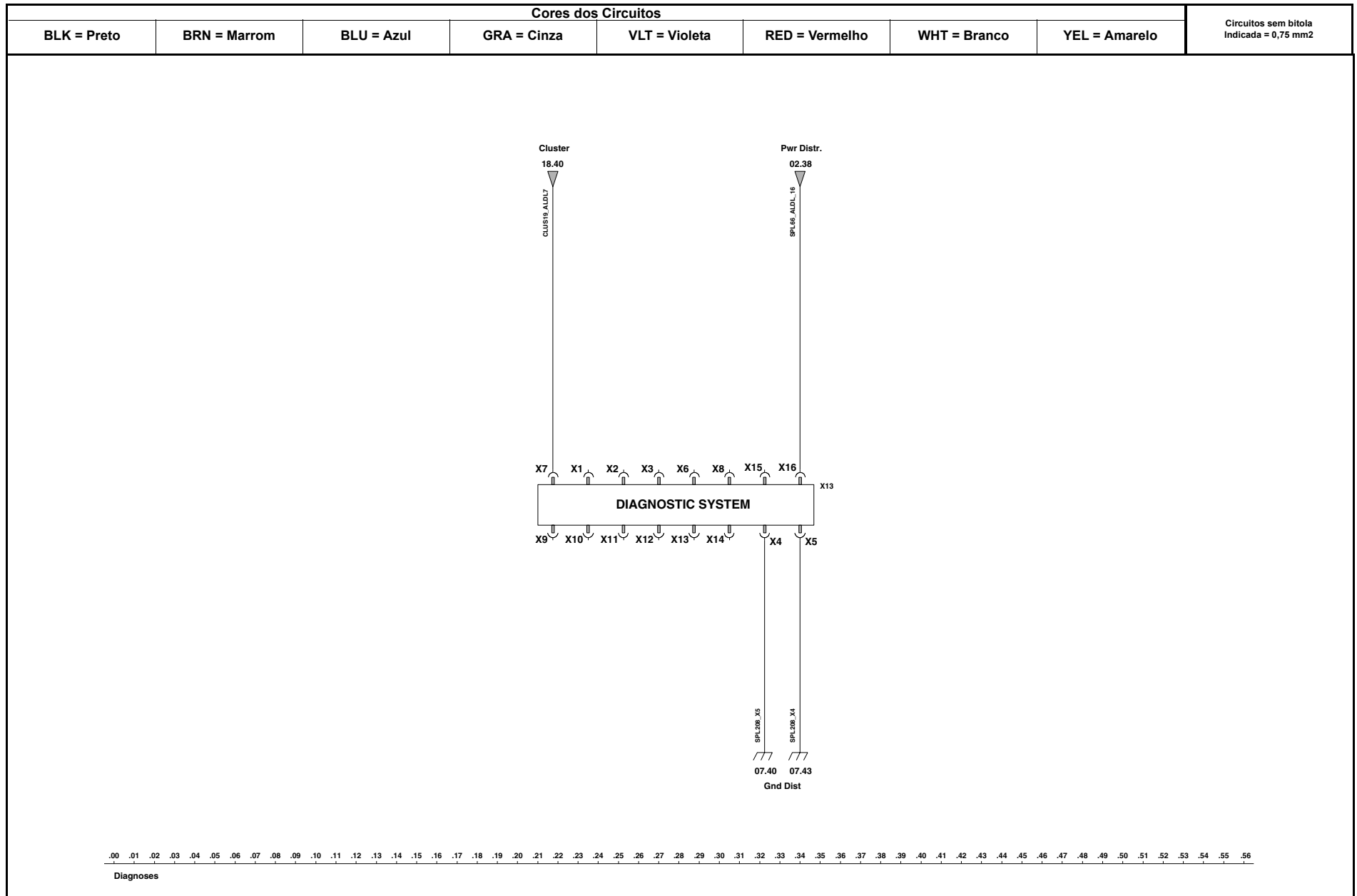

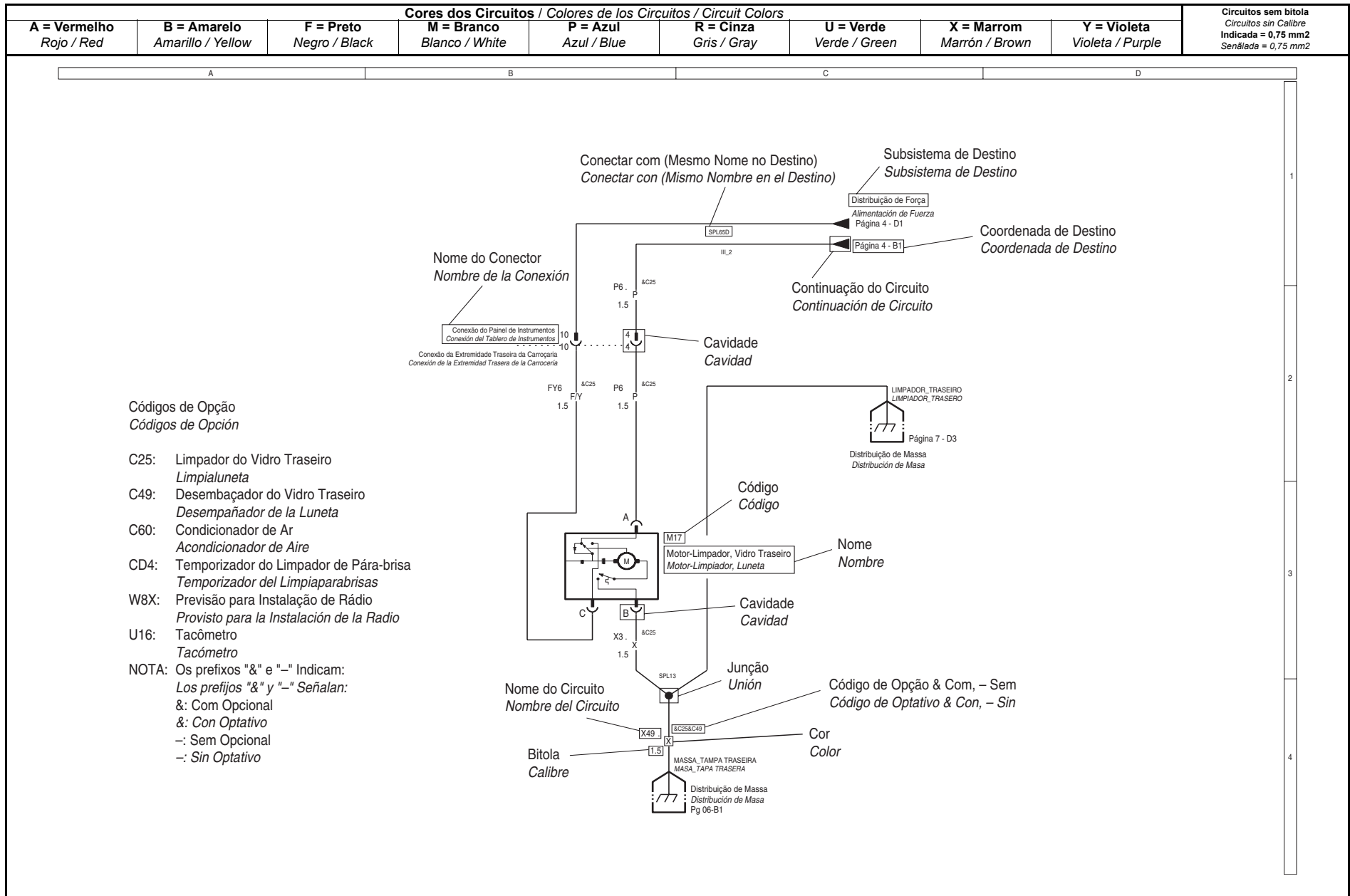

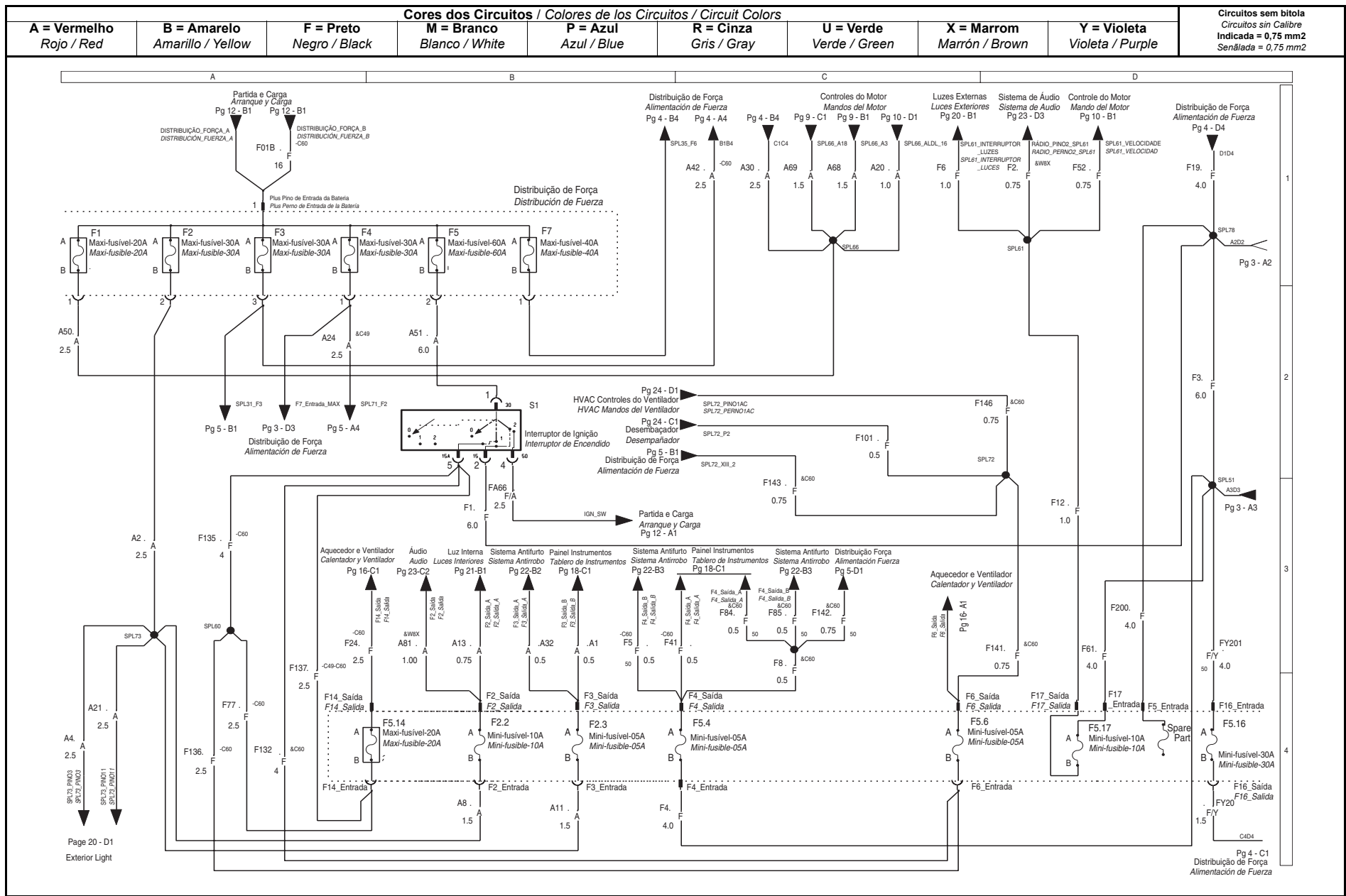

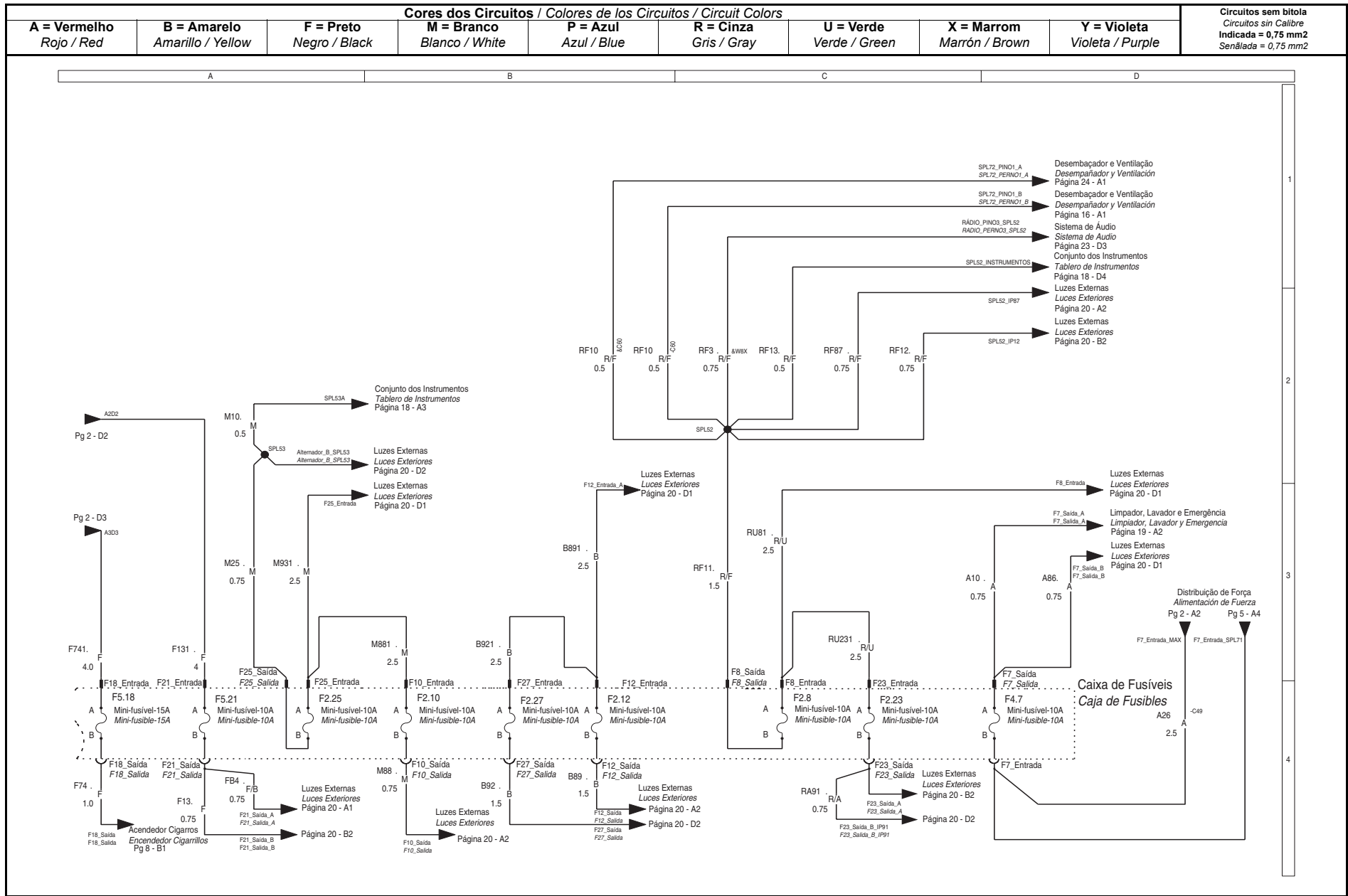

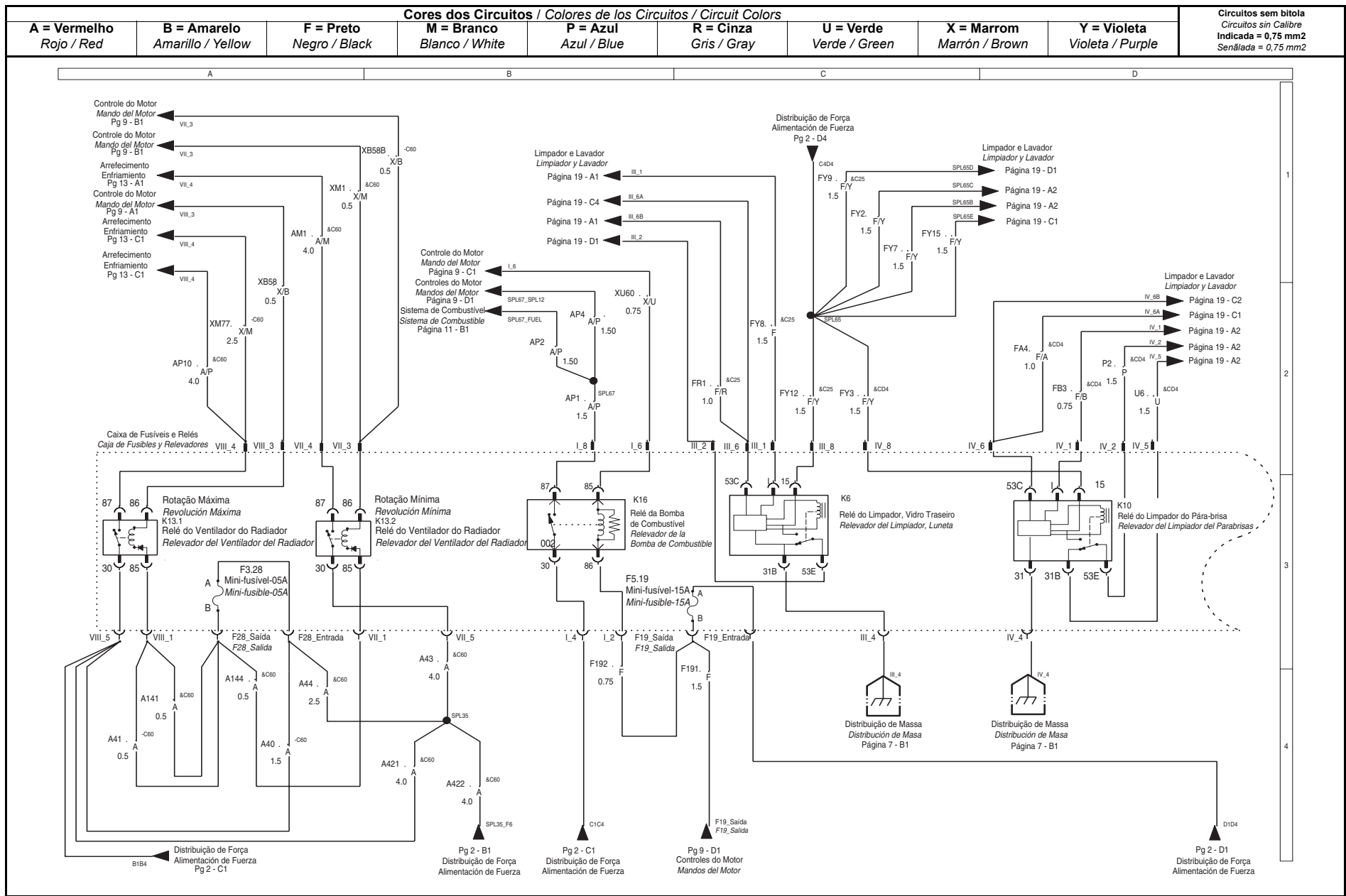

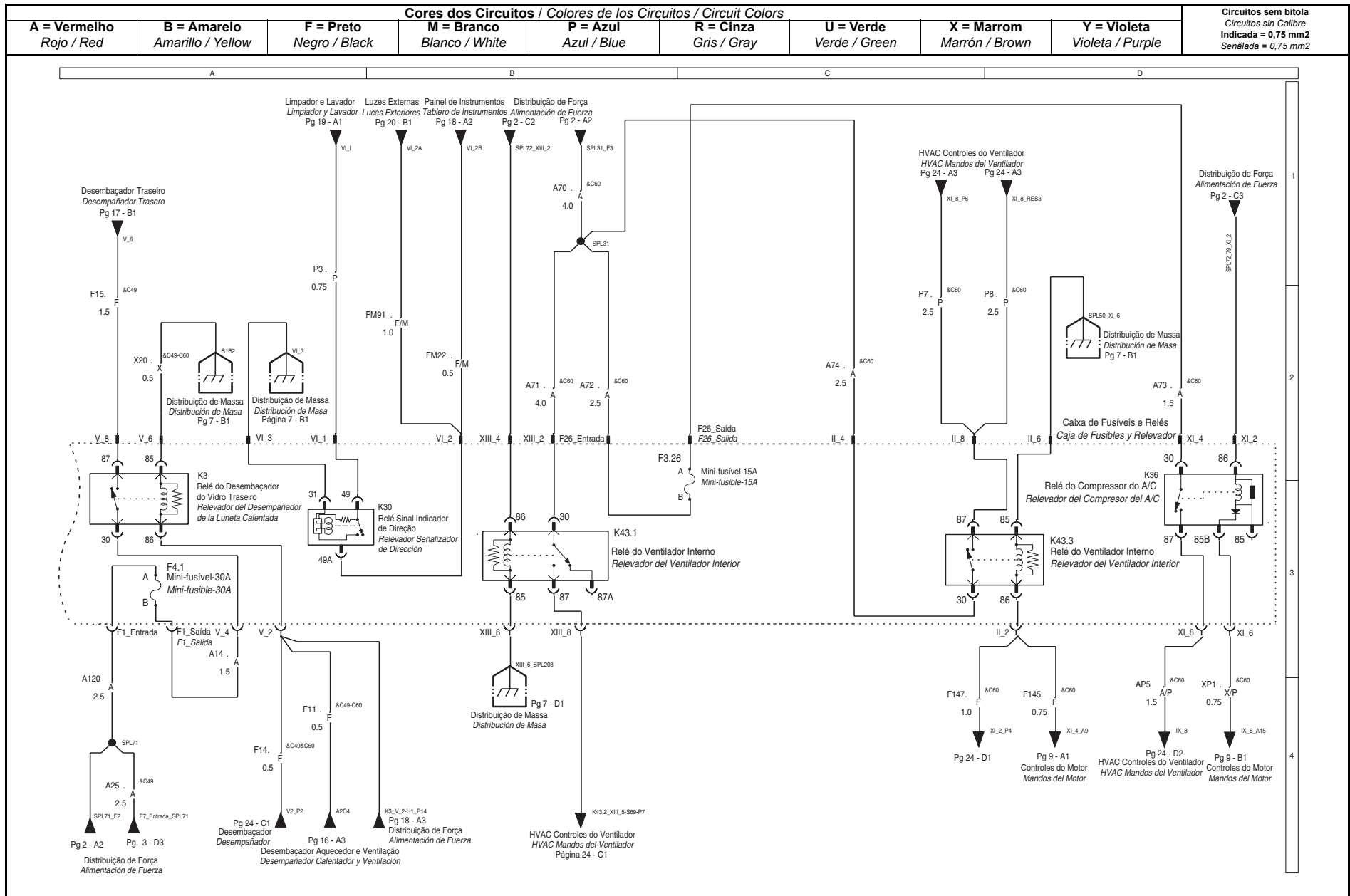

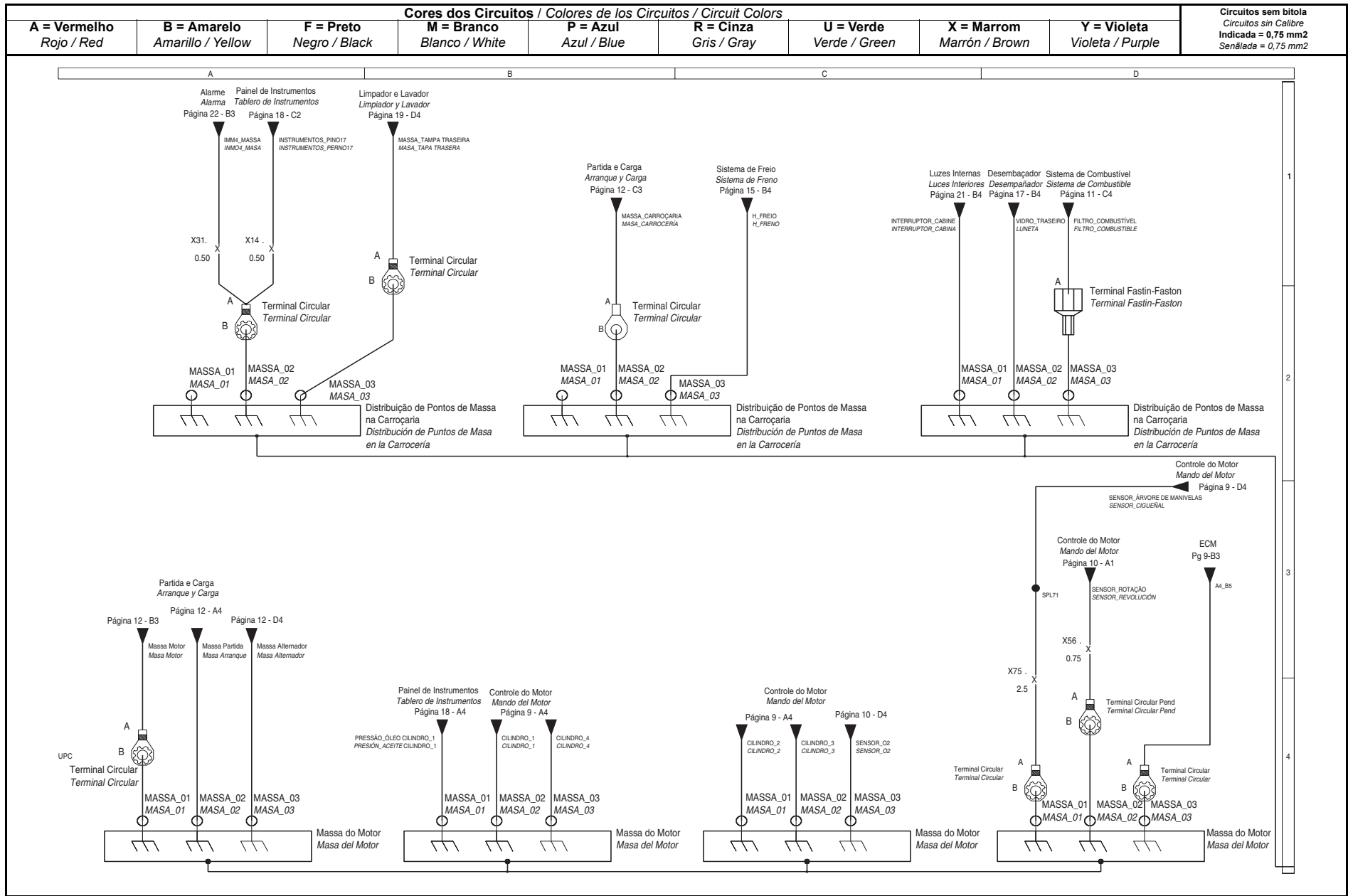

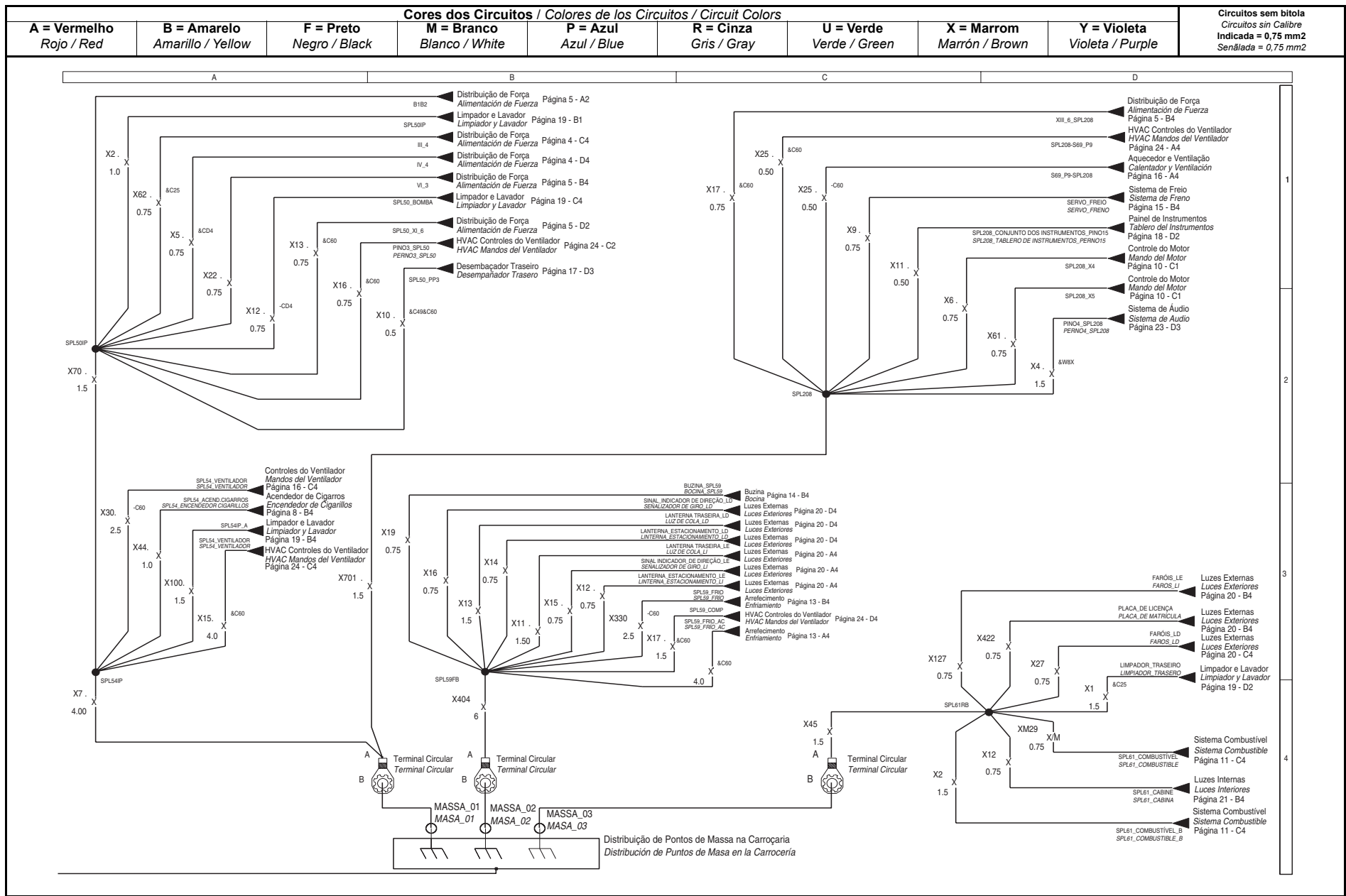

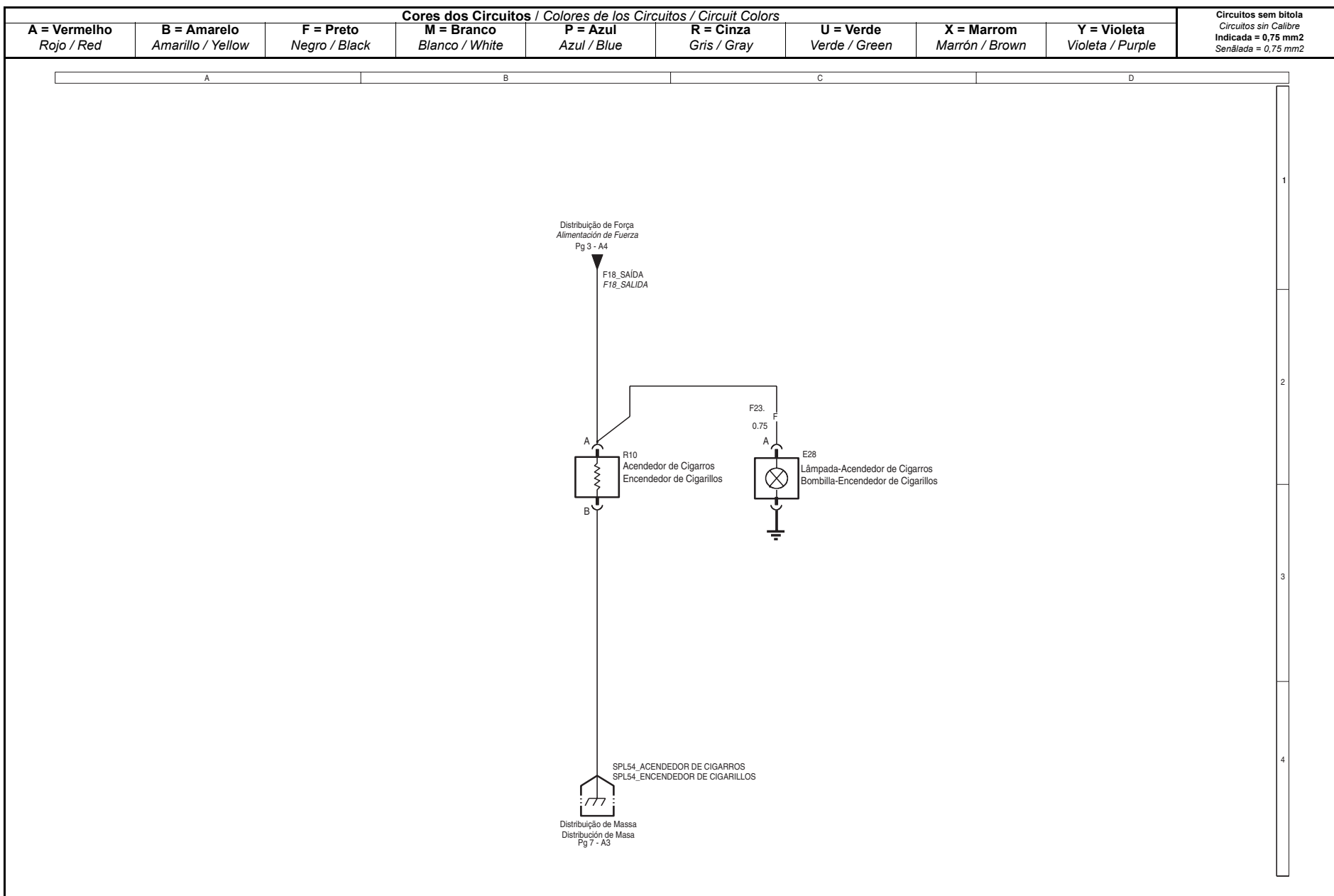

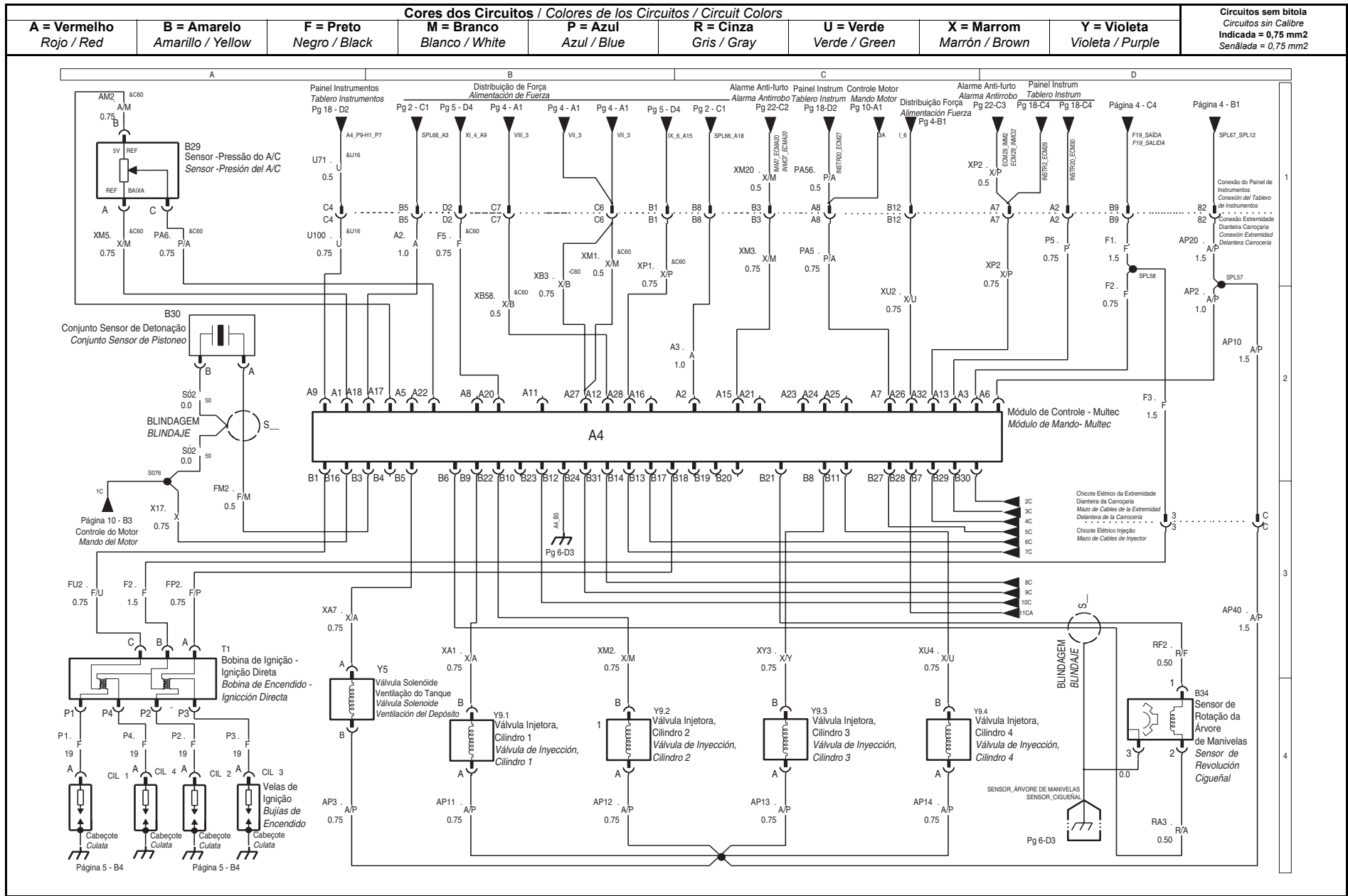

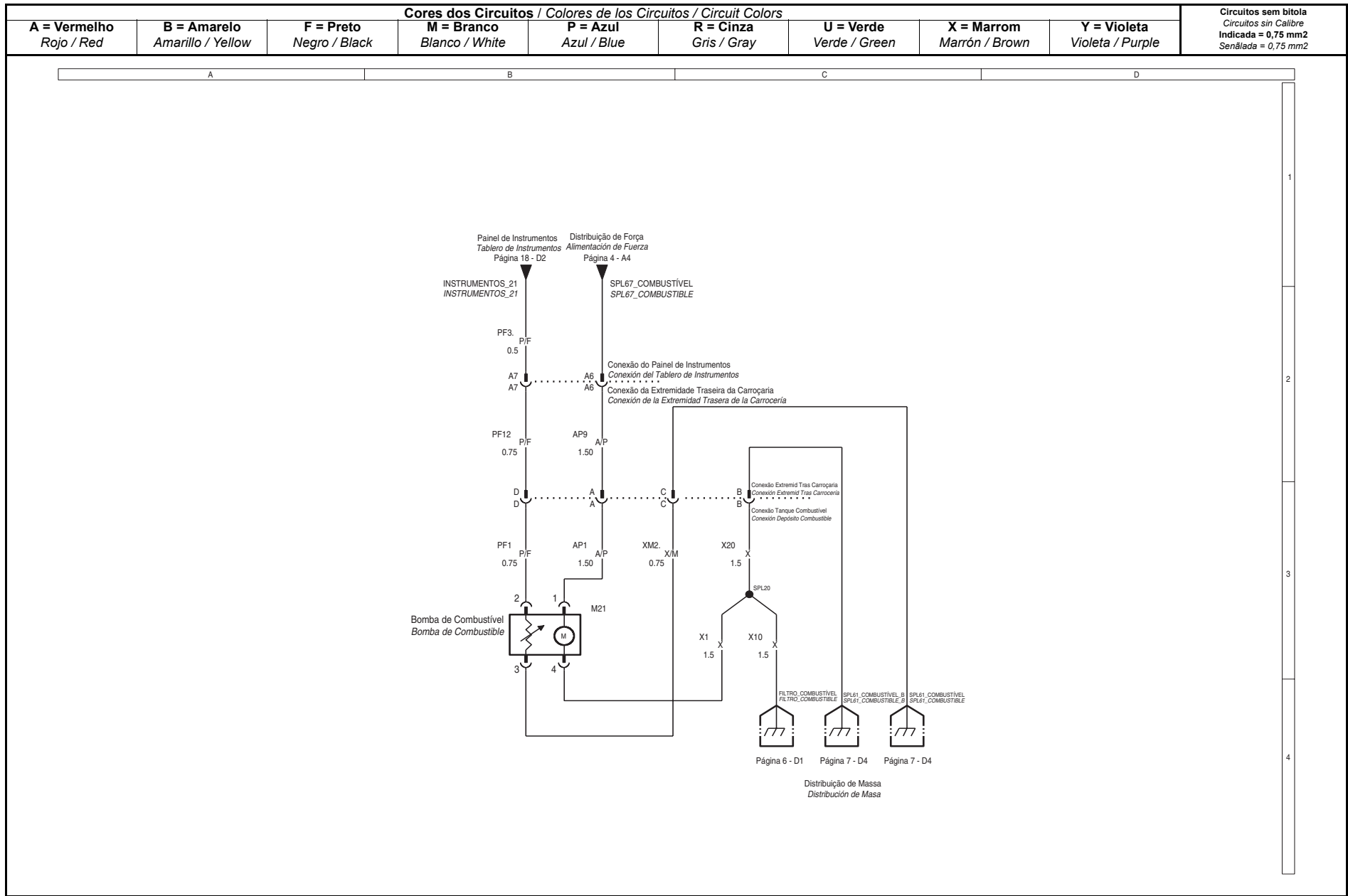

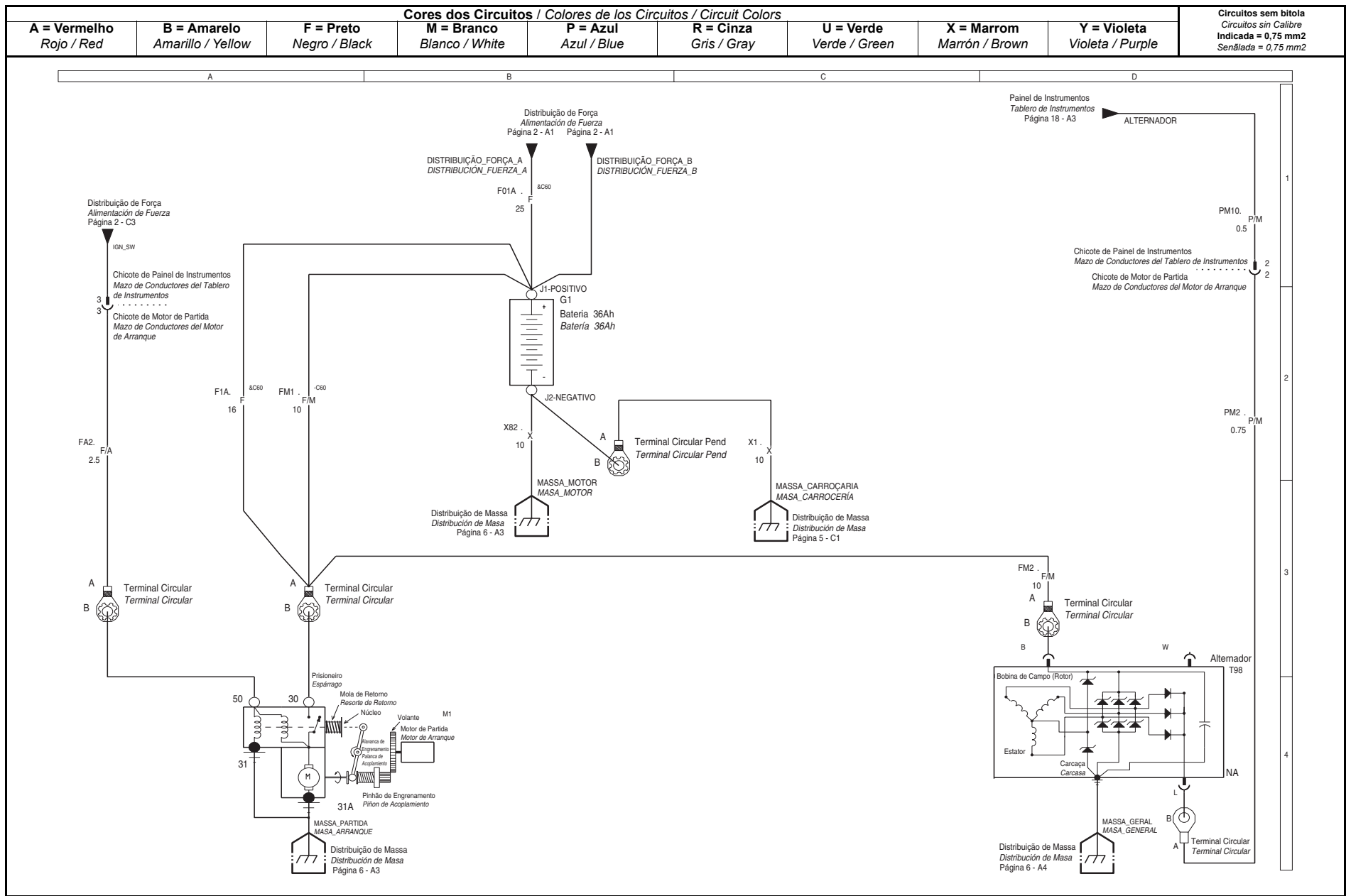

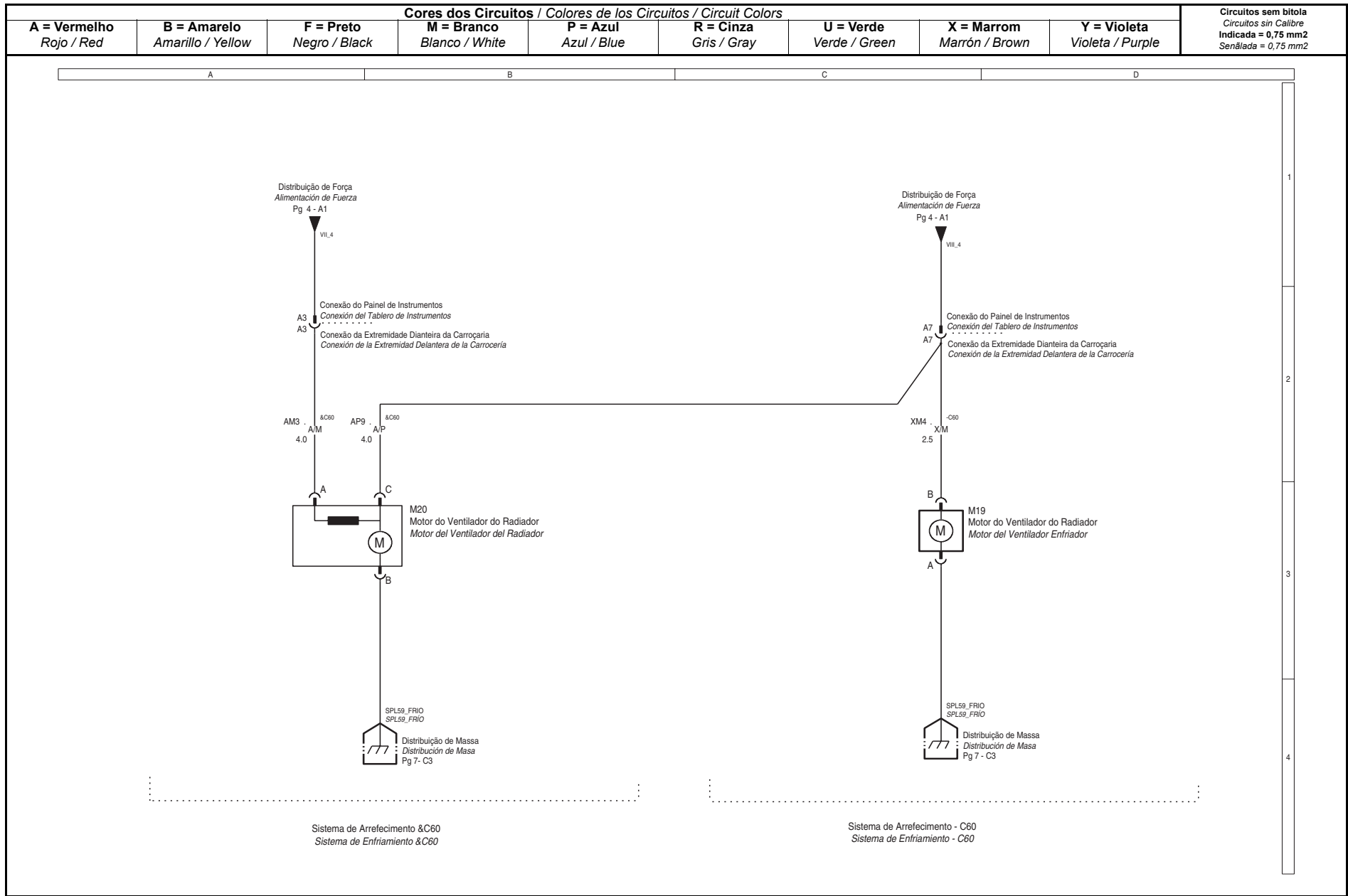

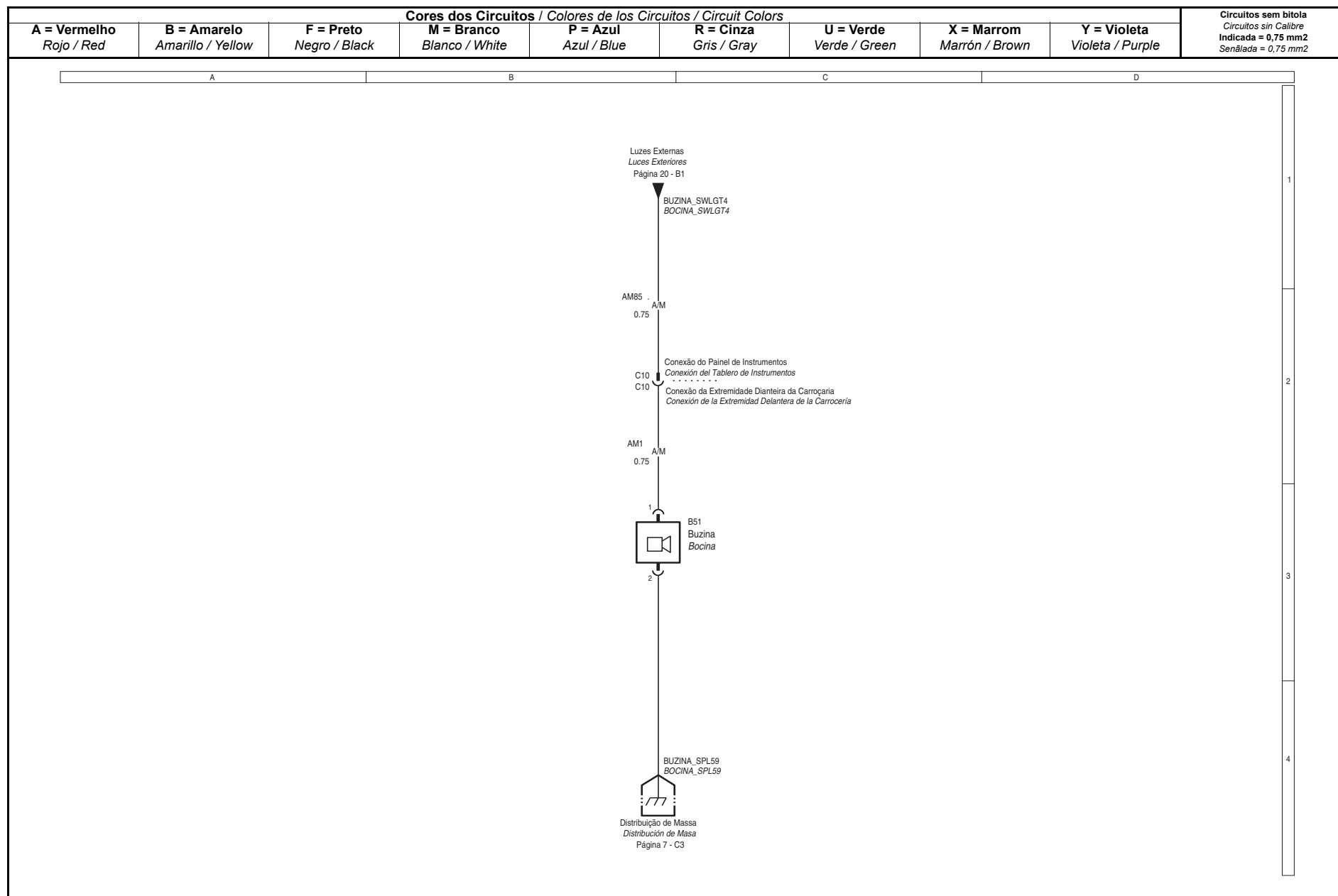

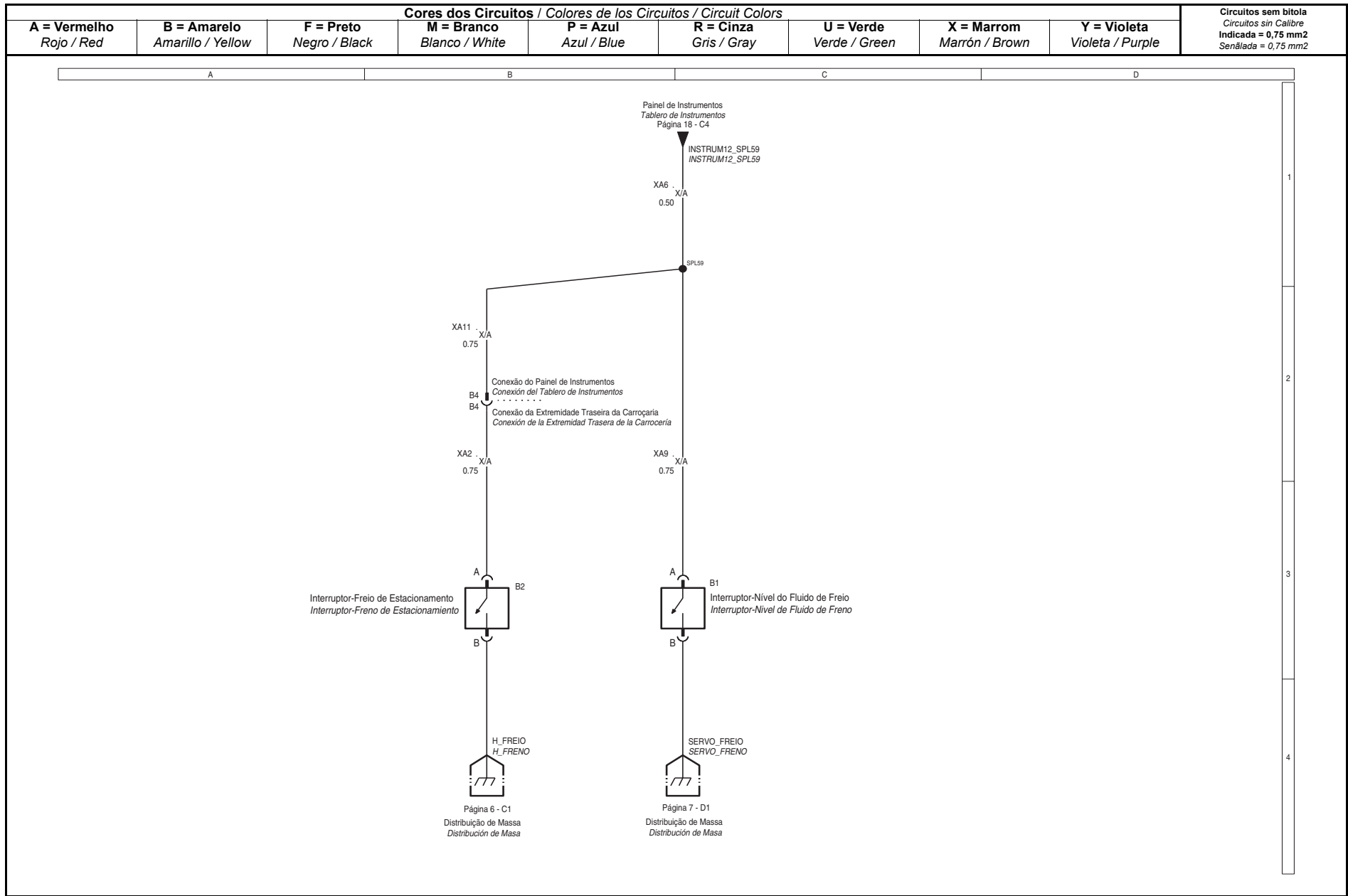

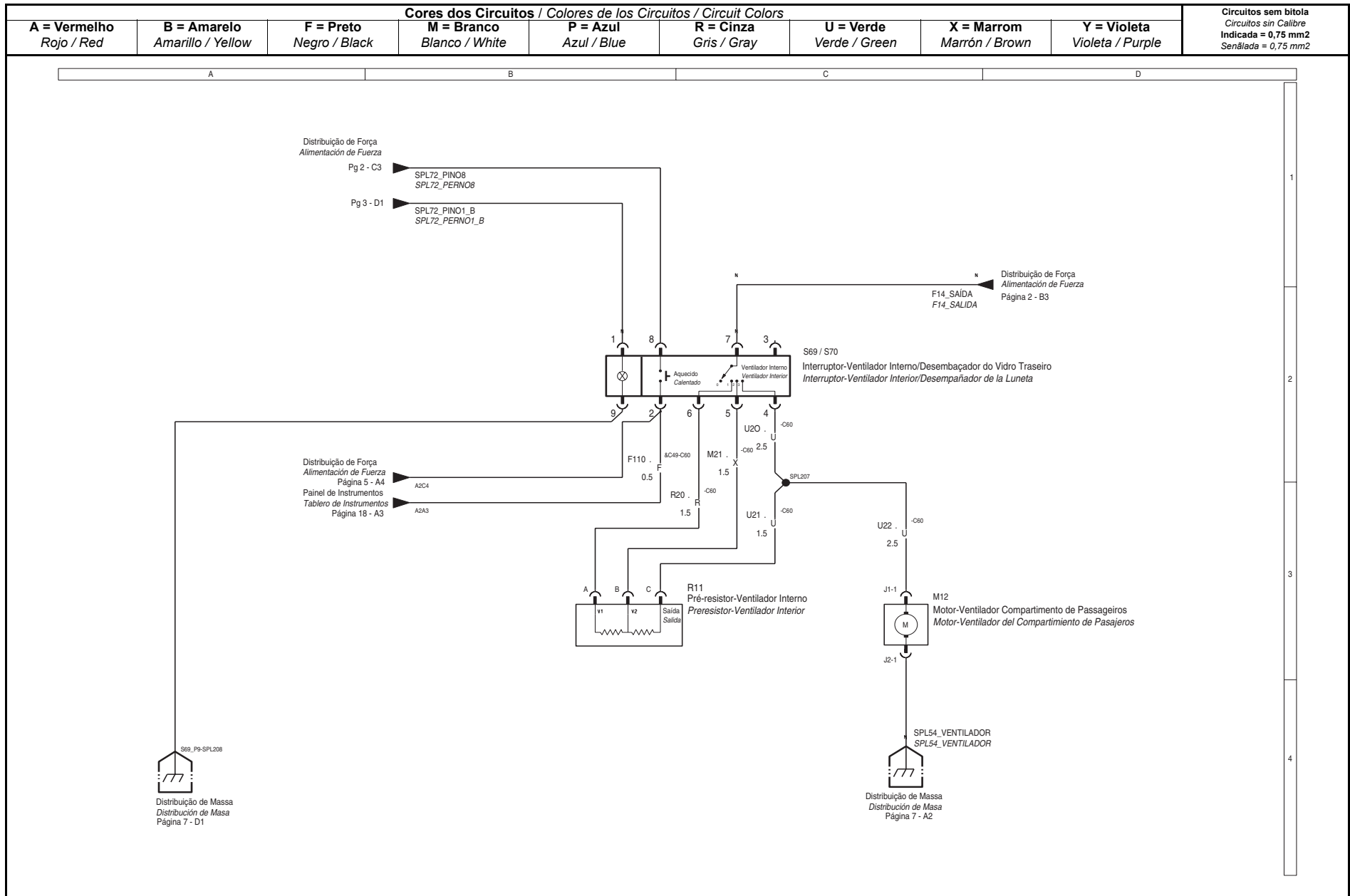

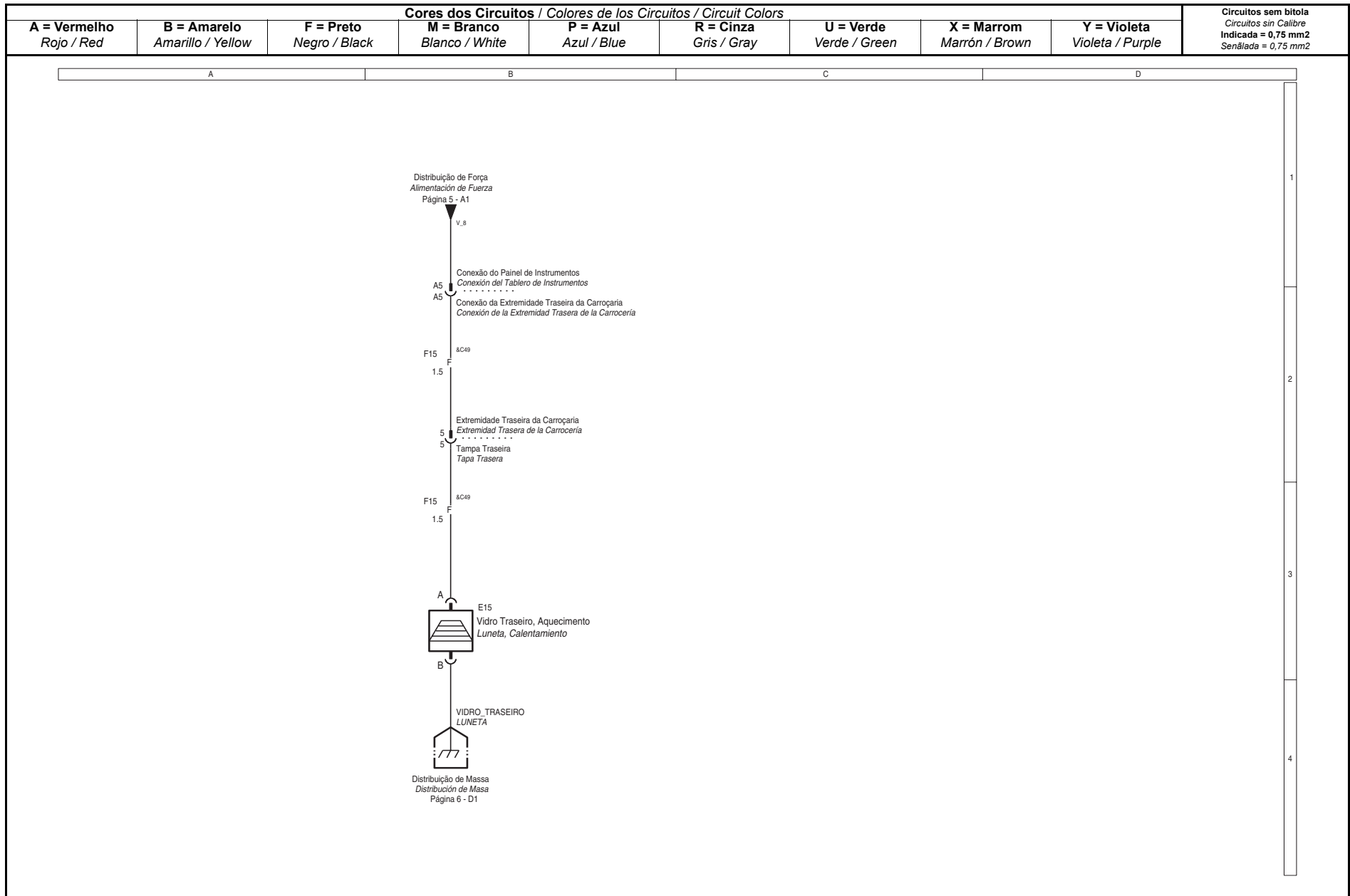

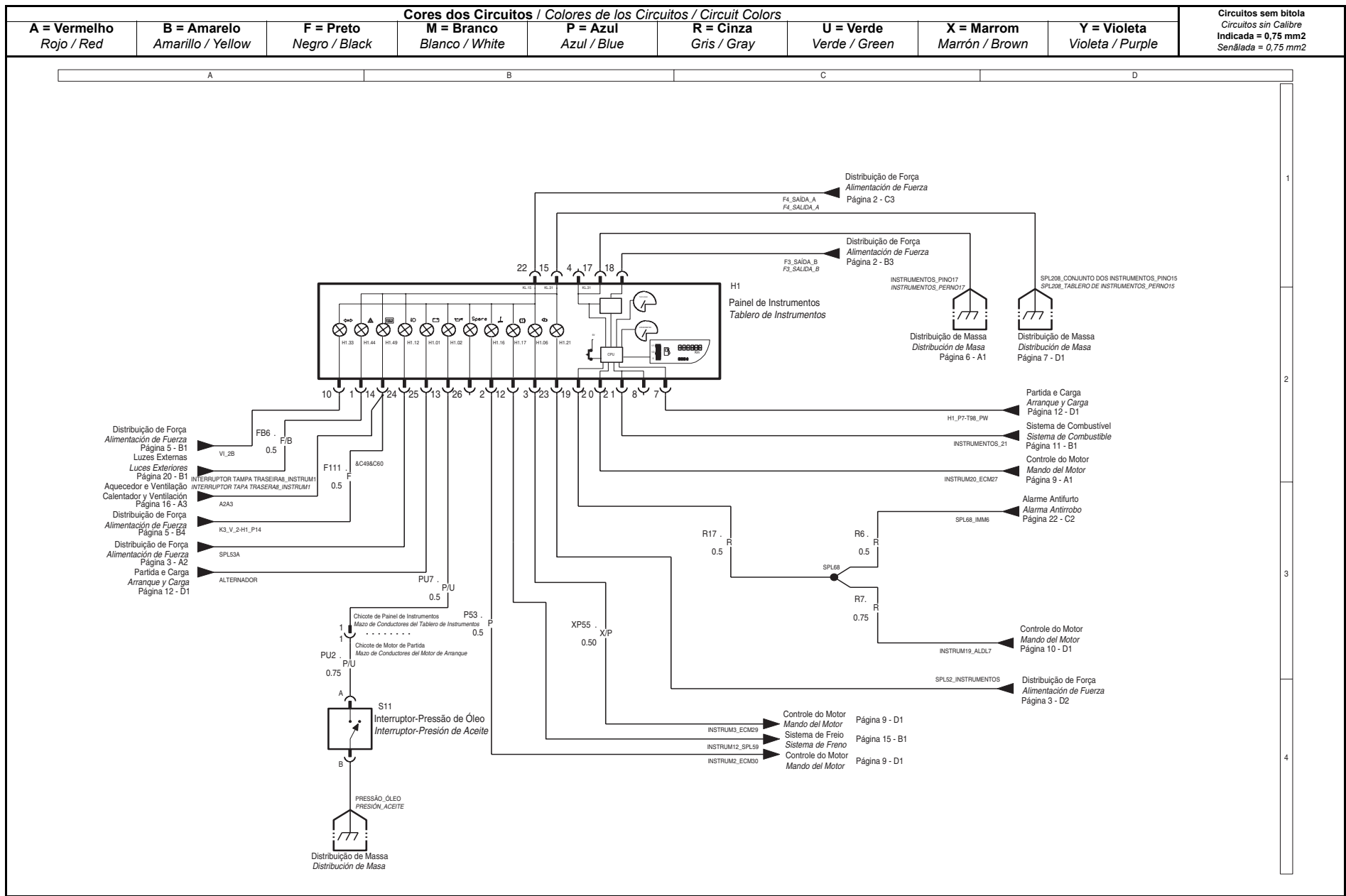

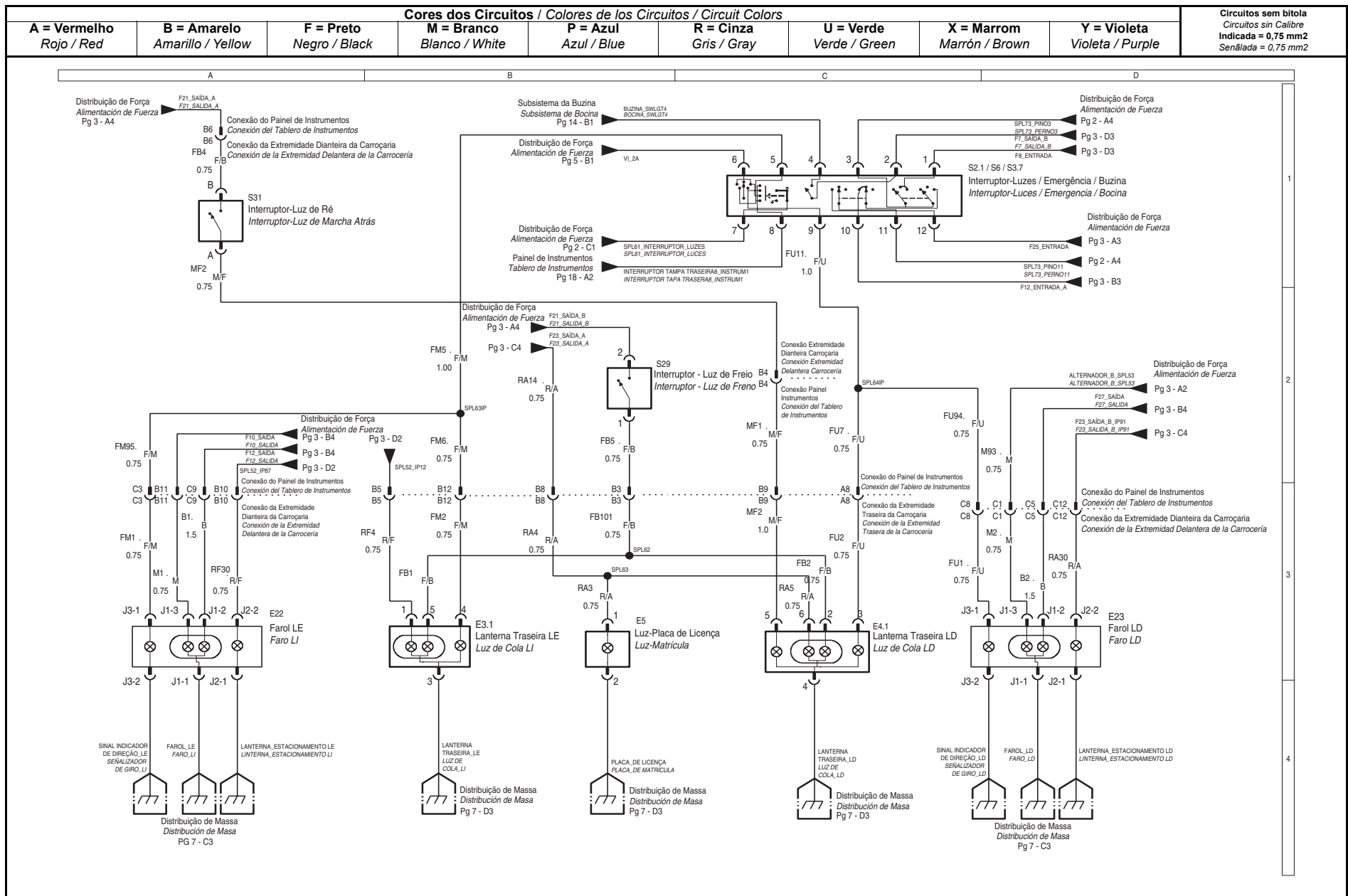

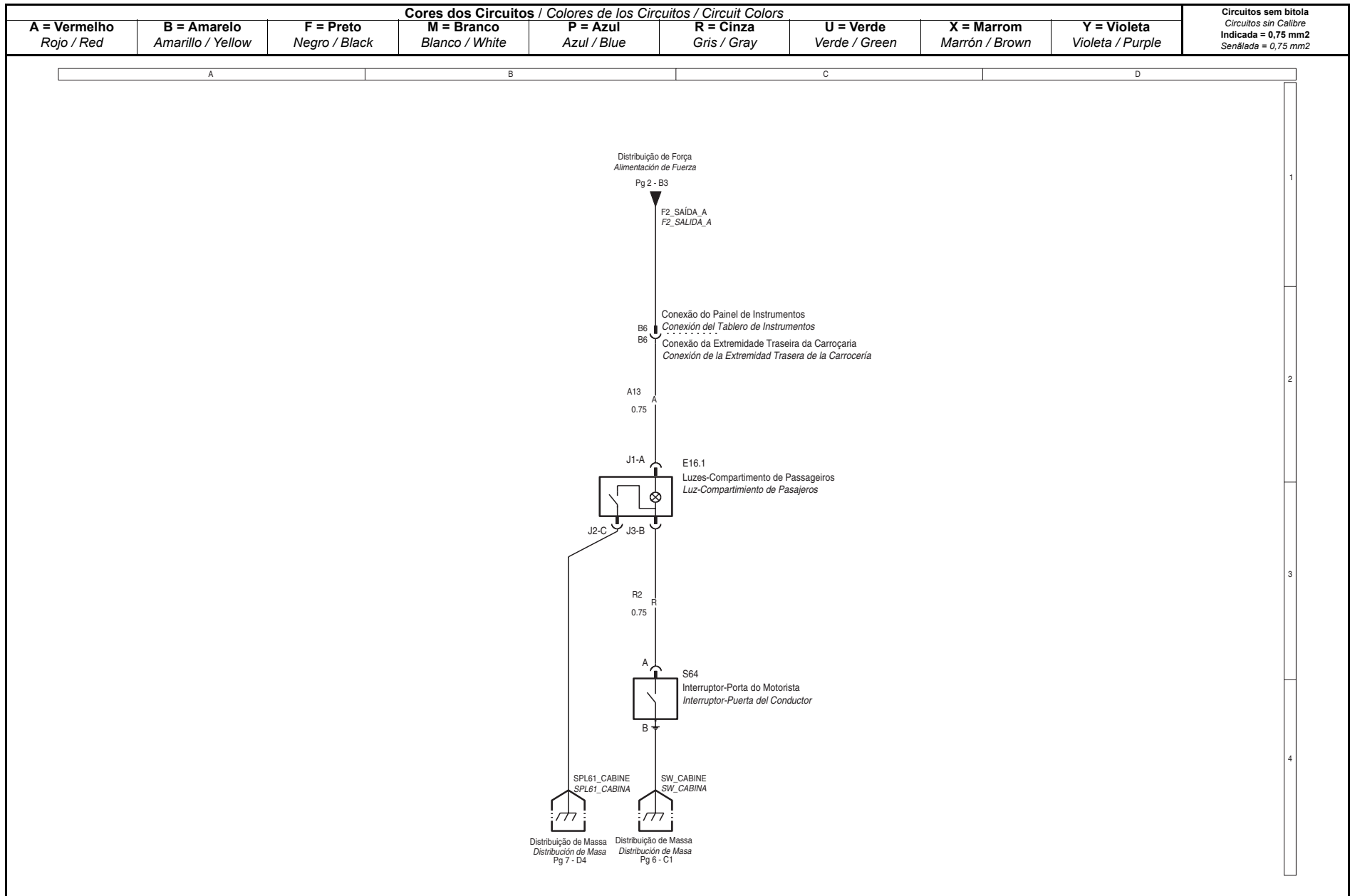

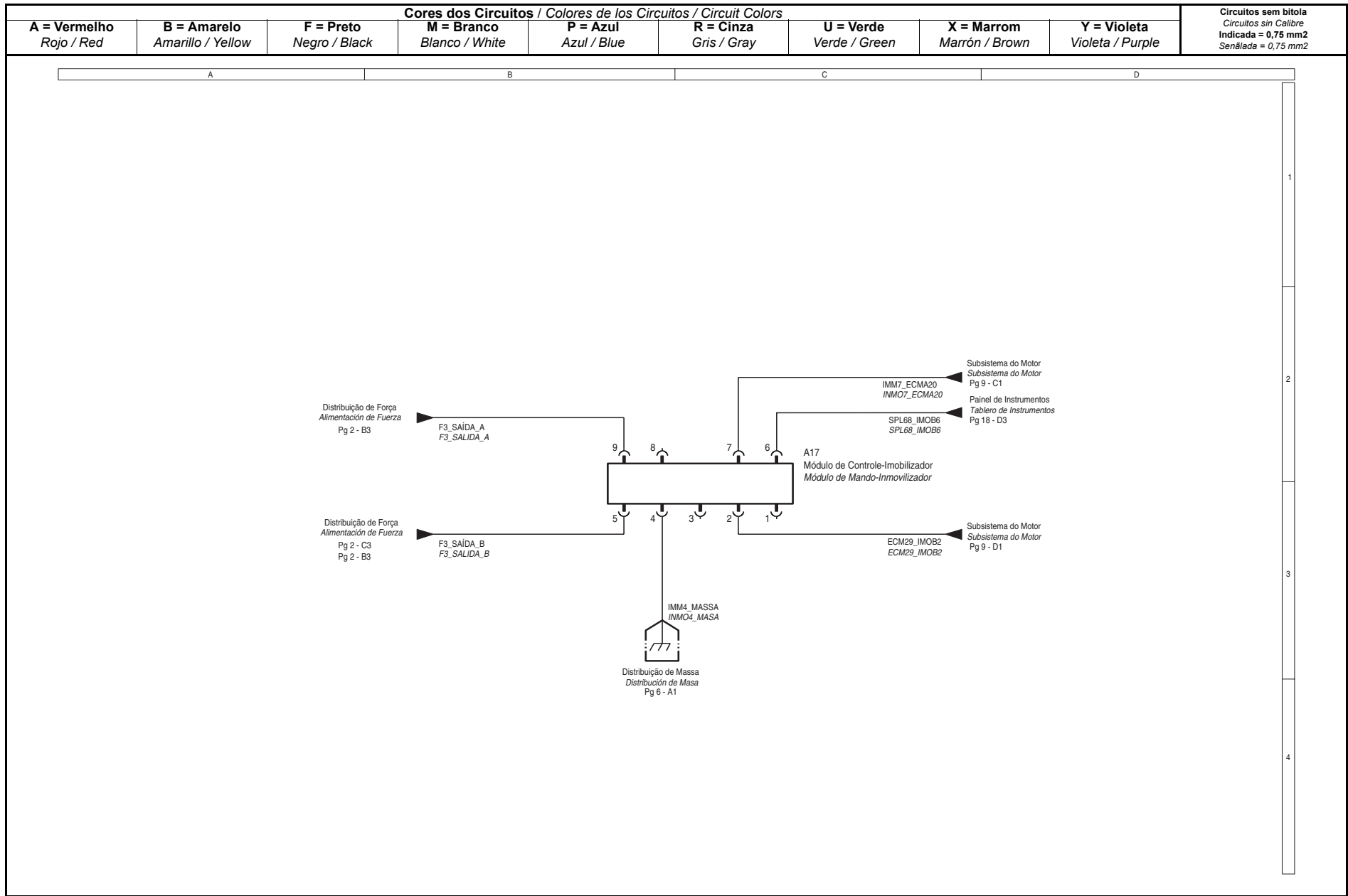

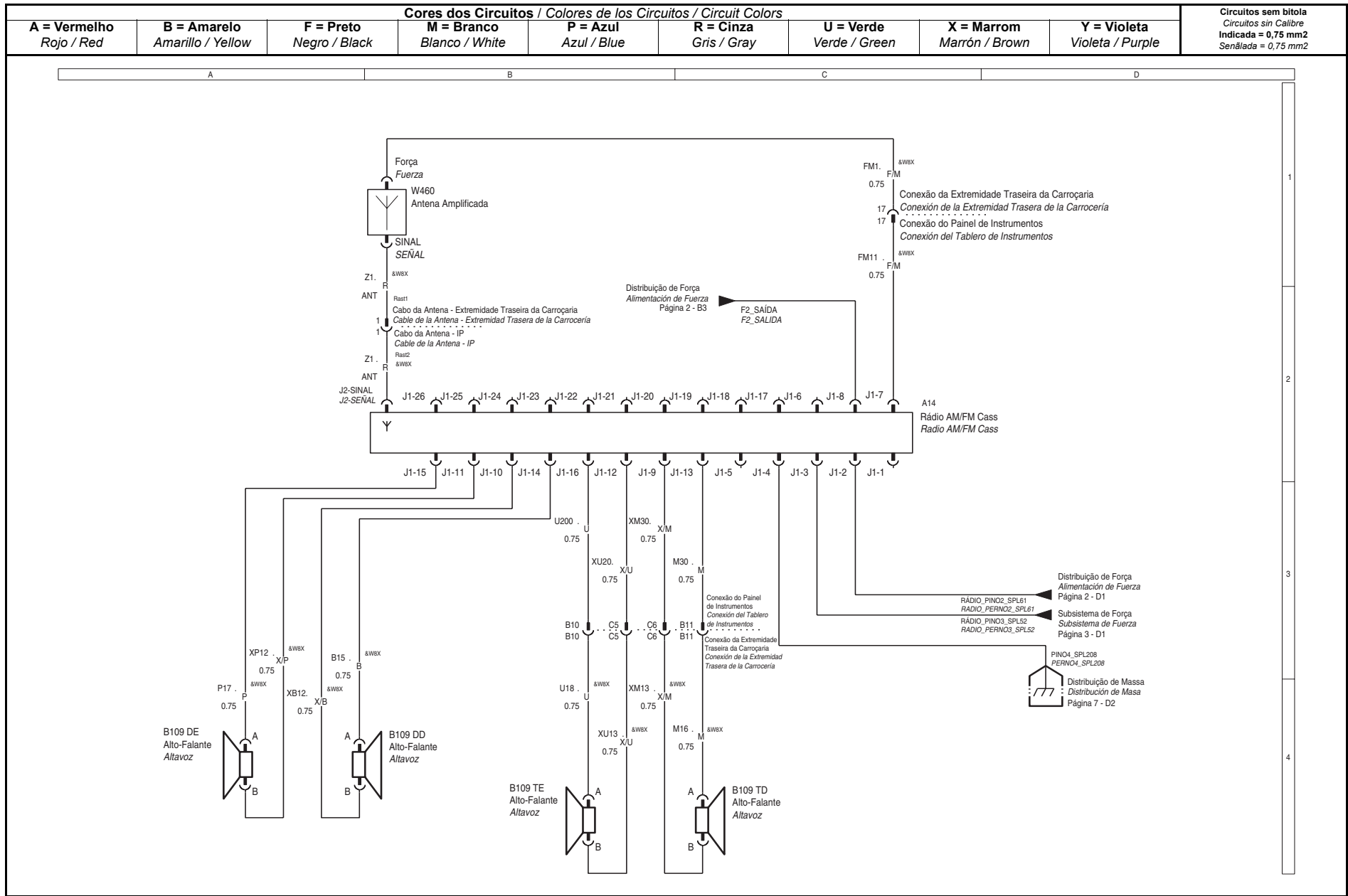

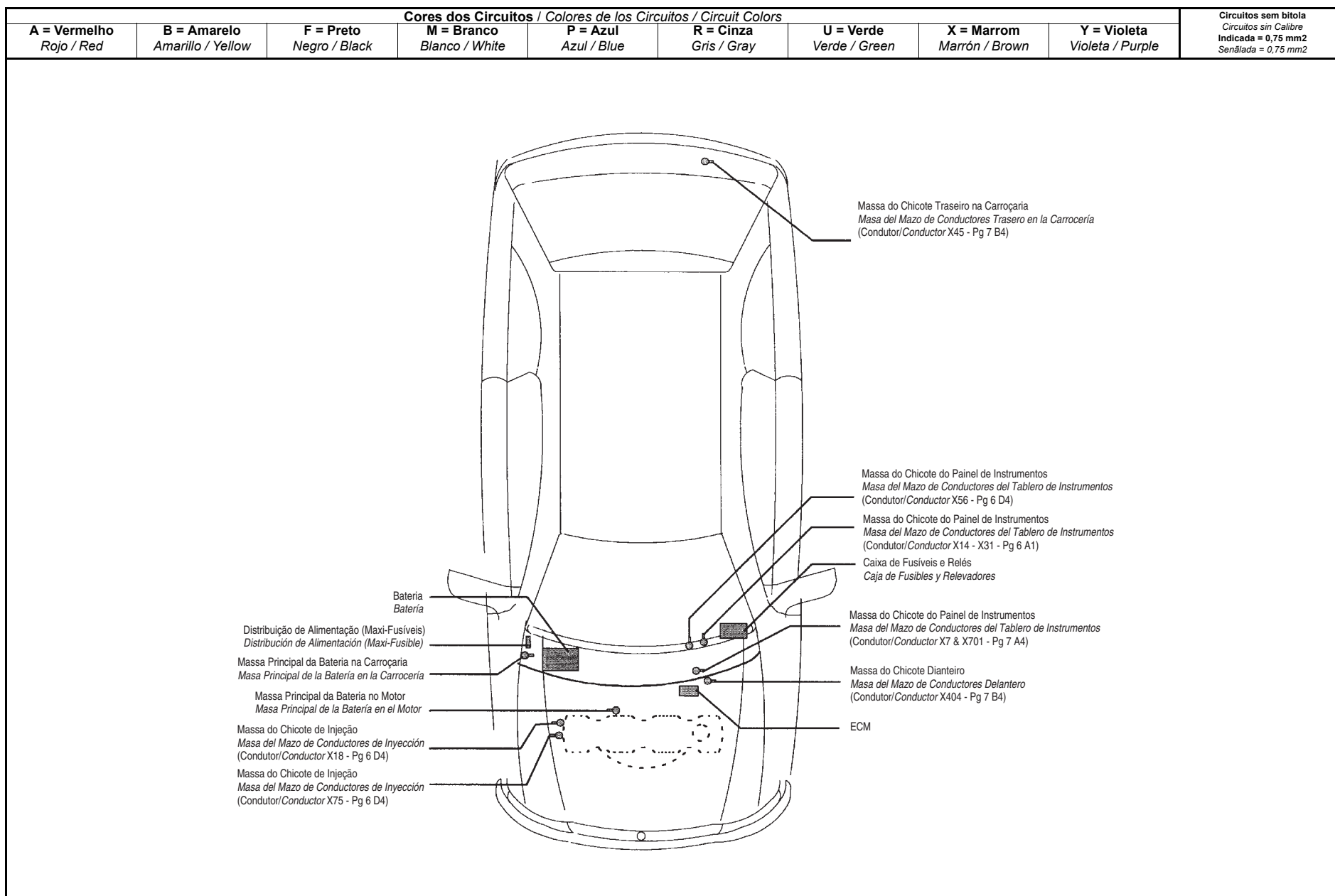

Código	Descrição Descripción	Página	Localização Localización
A14	Rádio <i>Radio</i>	23	B3
A17	Módulo - Imobilizador <i>Módulo - Inmovilizador</i>	22	B2
A4	Módulo de Controle (Multec) <i>Módulo de control (Multec)</i>	9	B2
B1	Interruptor - Nível de Fluido de Freio <i>Interruptor - Nivel de fluido de freno</i>	15	C3
B107	Sensor - Temperatura do Líquido de Arrefecimento <i>Sensor - Temperatura del Líquido de Enfriamiento</i>	10	C4
B109DD	Alto-Falante Dianteiro Esquerdo <i>Altavoz Delantero Izquierdo</i>	23	A4
B109DE	Alto-Falante Dianteiro Direito <i>Altavoz Delantero Derecho</i>	23	A4
B109TD	Alto-Falante Traseiro Direito <i>Altavoz Trasero Derecho</i>	23	C4
B109TE	Alto-Falante Traseiro Esquerdo <i>Altavoz Trasero Izquierdo</i>	23	B4
B2	Interruptor - Freio de Estacionamento <i>Interruptor - Freno de Estacionamiento</i>	15	B3
B24	Sensor de Velocidade (Sem ABS) <i>Sensor de Velocidad (Sin ABS)</i>	10	B2
B29	Sensor de Pressão (Transdutor) - Condicionador de Ar <i>Sensor de Presión (Transductor) - Acondicionador de Aire</i>	9	A1
B30	Sensor de Detonação <i>Sensor de Detonación</i>	9	A2
B34	Sensor de Rotação da Árvore de Manivelas <i>Sensor de Revolución del Cigüeñal</i>	9	D4



Código	Descrição <i>Descripción</i>	Página	Localização <i>Localización</i>
B45	Sensor de Posição da Borboleta - TPS <i>Sensor de Posición de la Mariposa de Aceleración - TPS</i>	10	D4
B51	Buzina <i>Bocina</i>	14	B3
B53	Sensor Lambda (Não Aquecido) <i>Sensor Lambda (No Calentado)</i>	10	A4
B69	Sensor de Temperatura e Pressão do Ar <i>Sensor de Temperatura y de Presión de Aire</i>	10	B4
E15	Desembaçador do Vidro Traseiro <i>Desempañador de la Luneta</i>	17	B3
E16.1	Lâmpada do Compartimento de Passageiro <i>Luz del Habitáculo</i>	21	B2
E22	Farol Esquerdo <i>Faro Izquierdo</i>	20	A3
E23	Farol Direito <i>Faro Derecho</i>	20	D3
E28	Lâmpada - Acendedor de Cigarros <i>Luz - Encendedor de Cigarrillos</i>	8	C2
E3.1	Lanterna Traseira Esquerda <i>Luz de Cola Izquierda</i>	20	B3
E4.1	Lanterna Traseira Direita <i>Luz de Cola Derecha</i>	20	C3
E5	Lâmpada da Placa de Licença <i>Luz de la Placa de la Matrícula</i>	20	B3
F1	Maxi-Fusível - Controles do Motor - 20A <i>Maxifusible - Mandos del Motor - 20A</i>	2	A1
F2	Maxi-Fusível - F2.2, F2.3 - 30A <i>Maxifusible - F2.2, F2.3 - 30A</i>	2	A1



Código	Descrição <i>Descripción</i>	Página	Localização <i>Localización</i>
F2.10	Mini-Fusível - Farol Alto LE - 10A <i>Minifusible - Luz Alta LI - 10A</i>	3	B4
F2.12	Mini-Fusível - Farol Baixo LE - 10A <i>Minifusible - Luz Baja LI - 10A</i>	3	B4
F2.2	Mini-Fusível - Luz Interna, Rádio - 10A <i>Minifusible - Luz Interior, Radio - 10A</i>	2	B4
F2.23	Mini-Fusível - Luz da Placa de Licença, Lanterna Traseira LD, Lanterna Dianteira LD - 10A <i>Minifusible - Luz de la Placa de la Matrícula, Luz de Cola LD, Luz Delantera LD - 10A</i>	3	C4
F2.25	Mini-Fusível - Farol Alto LD, Luz Indicadora de Farol Alto - 10A <i>Minifusible - Luz Alta LD, Luz Indicadora de la Luz Alta - 10A</i>	3	A4
F2.27	Mini-Fusível - Farol Baixo LD - 10A <i>Minifusible - Luz Baja LD - 10A</i>	3	B4
F2.3	Mini-Fusível - Iluminação do Painel de Instrumentos, Módulo de Controle do Imobilizador - 5A <i>Minifusible - Alumbrado del Tablero de Instrumentos, Módulo de Control del Inmovilizador - 5A</i>	2	B4
F2.8	Mini-Fusível - Iluminação do Interruptor do Ventilador Interno, Rádio, Iluminação do Painel de Instrumentos, Lanterna Dianteira LE, Lanterna Traseira LE - 10A <i>Minifusible - Alumbrado del Interruptor del Ventilador Interior, Radio, Alumbrado del Tablero de Instrumentos, Luz Delantera L.I., Luz de Cola L.I. - 10A</i>	3	C4
F3	Maxi-Fusível - Relés do Ventilador Interno, Relé do Ventilador do Radiador - Velocidade Baixa, Relé do Ventilador do Radiador - Velocidade Alta - 30A <i>Maxifusible - Relevadores del Ventilador Interior, Relevador del Ventilador del Radiador - Velocidad Baja, Relevador del Ventilador del Radiador - Velocidad Alta - 30A</i>	2	A1
F3.26	Mini-Fusível - Relé do Compressor do A/C - 15A <i>Minifusible - Relevador del Compresor del A/C - 15A</i>	5	C2
F3.28	Mini-Fusível - Relé do Ventilador do Radiador - Velocidade Baixa, Relé do Ventilador do Radiador - Velocidade Alta - 5A <i>Minifusible - Relevador del Ventilador del Radiador - Velocidad Baja, Relevador del Ventilador del Radiador - Velocidad Alta - 5A</i>	4	A3
F4	Maxi-Fusível - F4.7, F4.1, Interruptor de Luzes - 30A <i>Maxifusible - F4.7, F4.1, Interruptor de las Luces - 30A</i>	2	A1



Código	Descrição <i>Descripción</i>	Página	Localização <i>Localización</i>
F4.1	Mini-Fusível - Relé do Desembaçador do Vidro Traseiro - 30A <i>Minifusible - Relevador del Desempañador de la Luneta - 30A</i>	5	A4
F4.7	Mini-Fusível - Interruptor de Emergência - Buzina - 10A <i>Minifusible - Interruptor de Emergencia - Bocina - 10A</i>	3	D4
F5	Maxi-Fusível - Interruptor de Ignição - 60A <i>Maxifusible - Interruptor de Encendido - 60A</i>	2	B1
F5.14	Maxi-Fusível - Interruptor do Ventilador Interno - 20A <i>Maxifusible - Interruptor del Ventilador Interior - 20A</i>	2	B4
F5.16	Mini-Fusível - Relé do Limpador do Pára-brisa, Relé do Limpador do Vidro Traseiro, Motor do Limpador do Pára-brisa, Interruptor do Limpador - 30A <i>Minifusible - Relevador del Limpiaparabrisas, Relevador del Limpialuneta, Motor del Limpiaparabrisas, Interruptor del Limpiador - 30A</i>	2	D4
F5.17	Mini-Fusível - Interruptor do Indicador de Direção, Emergência, Rádio, Sensor de Velocidade - 10A <i>Minifusible - Interruptor del Señalizador de Giro, Emergencia, Radio, Sensor de Velocidad - 10A</i>	2	D4
F5.18	Mini-Fusível - Acendedor de Cigarros - 15A <i>Minifusible - Encendedor de Cigarrillos - 15A</i>	3	A4
F5.19	Mini-Fusível - Relé da Bomba de Combustível - Módulo de Controle do Motor, Bobina de Ignição - 15A <i>Minifusible - Relevador de la Bomba de Combustible - Módulo de Control del Motor, Bobina de Encendido - 15A</i>	4	C3
F5.21	Mini-Fusível - Interruptor de Luz de Ré, Interruptor de Luz de Freio - 10A <i>Minifusible - Interruptor de la Luz de Marcha Atrás, Interruptor de la Luz de Freno - 10A</i>	3	A4
F5.4	Mini-Fusível - Módulo de Controle do Imobilizador, Iluminação do Painel de Instrumentos, Relé do Compressor do A/C - 5A <i>Minifusible - Módulo de Control del Inmovilizador, Alumbrado del Tablero de Instrumentos, Relevador del Compresor del A/C - 5A</i>	2	C4
F5.6	Mini-Fusível - Interruptor do Desembaçador do Vidro Traseiro, Relé do Ventilador Interno, Interruptor do Ventilador Interno, Interruptor de Pressão do A/C - 5A <i>Minifusible - Interruptor del Desempañador de la Luneta, Relevador del Ventilador Interior, Interruptor del Ventilador Interior, Interruptor de Presión del A/C - 5A</i>	2	C4



Código	Descrição <i>Descripción</i>	Página	Localização <i>Localización</i>
F7	Maxi-Fusível - Relé do Ventilador do Radiador - Velocidade Baixa, Relé do Ventilador do Radiador - Velocidade Alta, F3.28 - 40A <i>Maxifusible - Relevador del Ventilador del Radiador - Velocidad Baja, Relevador del Ventilador del Radiador - Velocidad Alta, F3.28 - 40A</i>	2	B1
G1	Bateria <i>Batería</i>	12	B2
H1	Painel de Instrumentos <i>Tablero de Instrumentos</i>	18	B2
H1.02	Lâmpada Indicadora de Pressão de Óleo <i>Luz Indicadora de Presión de Aceite</i>	18	B2
H1.06	Lâmpada Indicadora de Falha do Sistema de Injeção <i>Luz Indicadora de Falla del Sistema de Inyección</i>	18	B2
H1.1	Lâmpada Indicadora de Carga <i>Luz Indicadora de Carga</i>	18	B2
H1.12	Lâmpada Indicadora de Farol Alto <i>Luz Indicadora de Luz Alta</i>	18	B2
H1.16	Lâmpada Indicadora de Temperatura <i>Luz Indicadora de Temperatura</i>	18	B2
H1.17	Lâmpada Indicadora de Nível Baixo do Fluido de Freio e Freio de Estacionamento <i>Luz Indicadora de Nivel Bajo de Fluido de Freno y Freno de Estacionamiento</i>	18	B2
H1.21	Lâmpadas - Iluminação do Painel de Instrumentos <i>Luces - Alumbrado del Tablero de Instrumentos</i>	18	B2
H1.33	Lâmpada Indicadora de Direção <i>Luz Indicadora de Giro</i>	18	A2
H1.44	Lâmpada Indicadora de Advertência <i>Luz Indicadora de Advertencia</i>	18	A2
H1.49	Lâmpada Indicadora do Desembaçador do Vidro Traseiro <i>Luz Indicadora del Desempañador del Limpialuneta</i>	18	B2



Código	Descrição <i>Descripción</i>	Página	Localização <i>Localización</i>
M17	Motor do Limpador do Vidro Traseiro <i>Motor del Limpialuneta</i>	19	C3
M19	Motor do Ventilador do Radiador <i>Motor del Ventilador del Radiador</i>	13	C3
M20	Motor do Ventilador do Radiador (A/C) <i>Motor del Ventilador del Radiador (A/C)</i>	13	B3
M21	Bomba Elétrica de Combustível <i>Bomba Eléctrica de Combustible</i>	11	B3
M22	Bomba de Água - Limpador do Pára-brisa e Vidro Traseiro <i>Bomba de Agua - Limpiador del Parabrisas y de la Luneta</i>	19	C3
M24	Motor Escalonador da Borboleta de Aceleração <i>Motor de Paso de la Mariposa de Aceleración</i>	10	C4
M44	Compressor do Ar Condicionado <i>Compresor del Acondicionador de Aire</i>	24	D3
R10	Acendedor de Cigarros <i>Encendedor de Cigarrillos</i>	8	B2
R11	Pré-Resistor - Ventilador Interno (Sem A/C) <i>Resistor Previo - Ventilador Interior (Sin A/C)</i>	16	B3
R21	Pré-Resistor - Ventilador Interno (Com A/C) <i>Resistor Previo - Ventilador Interior (Con A/C)</i>	24	B3
S1	Interruptor de Ignição <i>Interruptor de Encendido</i>	2	B2
S11	Interruptor - Pressão de Óleo <i>Interruptor - Presión de Aceite</i>	18	A4
S2.1	Interruptor de Luz <i>Interruptor de Luz</i>	20	C1
S22	Interruptor do Limpador <i>Interruptor del Limpiador</i>	19	B1



Código	Descrição <i>Descripción</i>	Página	Localização <i>Localización</i>
S29	Interruptor - Luz de Freio <i>Interruptor - Luz de Freno</i>	20	B2
S3.7	Interruptor da Buzina <i>Interruptor de la Bocina</i>	20	C1
S31	Interruptor de Marcha a Ré <i>Interruptor de Marcha Atrás</i>	20	A1
S47	Interruptor do Condicionador de Ar <i>Interruptor del Acondicionador de Aire</i>	24	C2
S6	Interruptor - Sinalizador de Emergência <i>Interruptor - Señalizador de Emergencia</i>	19	B1
S6	Interruptor - Sinalizador de Emergência <i>Interruptor - Señalizador de Emergencia</i>	20	C1
S64	Interruptor - Porta Dianteira L.E. <i>Interruptor - Puerta Delantera L.I.</i>	21	B3
S69/S70	Interruptor - Ventilador Interno e Desembaçador do Vidro Traseiro <i>Interruptor - Ventilador Interior y Desempañador de la Luneta</i>	16	B2
S69/S70	Interruptor - Ventilador Interno e Desembaçador do Vidro Traseiro <i>Interruptor - Ventilador Interior y Desempañador de la Luneta</i>	24	B2
S70	Interruptor - Ventilador Interno <i>Interruptor - Ventilador Interior</i>	16	B2
T1	Bobina de Ignição Direta <i>Bobina de Encendido Directo</i>	9	A3
T98	Alternador <i>Alternador</i>	12	D4
W460	Antena Integrada <i>Antena Integrada</i>	23	B1
X13	Conector de Diagnóstico DLC - 16p <i>Conexión de Diagnóstico DLC - 16p</i>	10	C3



Código	Descrição <i>Descripción</i>	Página	Localização <i>Localización</i>
K10	Relé do Limpador do Pára-brisa <i>Relevador del Limpiaparabrisas</i>	4	D3
K13.1	Relé - Motor do Ventilador do Radiador (2 Estágios) <i>Relevador - Motor del Ventilador del Radiador (2 Etapas)</i>	4	A3
K13.2	Relé - Motor do Ventilador do Radiador (1 Estágio) <i>Relevador - Motor del Ventilador del Radiador (1 Etapa)</i>	4	A3
K16	Relé - Bomba de Combustível <i>Relevador - Bomba de Combustible</i>	4	B3
K3	Relé - Desembaçador do Vidro Traseiro <i>Relevador - Desempañador de la Luneta</i>	5	A3
K30	Relé - Luz Indicadora de Direção <i>Relevador - Luz Señalizadora de Giro</i>	5	B3
K36	Relé do Compressor A/C - 5A <i>Relevador del Compresor del A/C - 5A</i>	5	D3
K43.1	Relé do Ventilador Interno <i>Relevador del Ventilador Interior</i>	5	B3
K43.3	Relé do Ventilador Interno <i>Relevador del Ventilador Interior</i>	5	D3
K6	Relé do Limpador do Vidro Traseiro <i>Relevador del Limpialuneta</i>	4	C3
M1	Motor de Partida <i>Motor de Arranque</i>	12	A4
M12	Motor - Ventilador Interno <i>Motor - Ventilador Interior (A/C)</i>	16	C3
M13	Motor - Ventilador Interno (A/C) <i>Motor - Ventilador Interior (A/C)</i>	24	C3
M16	Motor do Limpador do Pára-brisa <i>Motor del Limpiaparabrisas</i>	19	A3



Código	Descrição Descripción	Página	Localização Localización
Y5	Válvula Solenóide - Ventilação do Reservatório de Combustível <i>Válvula Solenoide - Ventilación del Tanque de Combustible</i>	9	A4
Y9.1	Válvula Injetora - Cilindro 1 <i>Válvula de Inyección - Cilindro 1</i>	9	B4
Y9.2	Válvula Injetora - Cilindro 2 <i>Válvula de Inyección - Cilindro 2</i>	9	B4
Y9.3	Válvula Injetora - Cilindro 3 <i>Válvula de Inyección - Cilindro 3</i>	9	C4
Y9.4	Válvula Injetora - Cilindro 4 <i>Válvula de Inyección - Cilindro 4</i>	9	C4



Descrição Descripción	Código	Página	Localização Localización
Acendedor de Cigarros <i>Encendedor de Cigarrillos</i>	R10	8	B2
Alternador <i>Alternador</i>	T98	12	D4
Alto-Falante Dianteiro Direito <i>Altavoz Delantero Derecho</i>	B109DE	23	A4
Alto-Falante Dianteiro Esquerdo <i>Altavoz Delantero Izquierdo</i>	B109DD	23	A4
Alto-Falante Traseiro Direito <i>Altavoz Trasero Derecho</i>	B109TD	23	C4
Alto-Falante Traseiro Esquerdo <i>Altavoz Trasero Izquierdo</i>	B109TE	23	B4
Antena Integrada <i>Antena Integrada</i>	W460	23	B1
Bateria <i>Batería</i>	G1	12	B2
Bobina de Ignição Direta <i>Bobina de Encendido Directo</i>	T1	9	A3
Bomba de Água - Limpador do Pára-brisa e Vidro Traseiro <i>Bomba de Agua - Limpiaparabrisas y Luneta</i>	M22	19	C3
Bomba Elétrica de Combustível <i>Bomba Eléctrica de Combustible</i>	M21	11	B3
Buzina <i>Bocina</i>	B51	14	B3
Compressor do Ar Condicionado <i>Compresor del Acondicionador de Aire</i>	M44	24	D3
Conector de Diagnóstico DLC - 16p <i>Conexión de Diagnóstico DLC - 16p</i>	X13	10	C3



Descrição Descripción	Código	Página	Localização Localización
Desembaçador do Vidro Traseiro <i>Desempañador de la Luneta</i>	E15	17	B3
Farol Direito <i>Faro Derecho</i>	E23	20	D3
Farol Esquerdo <i>Faro Izquierdo</i>	E22	20	A3
Interruptor do Limpador <i>Interruptor del Limpiador</i>	S22	19	B1
Interruptor - Freio de Estacionamento <i>Interruptor - Freno de Estacionamiento</i>	B2	15	B3
Interruptor - Luz de Freio <i>Interruptor - Luz de Freno</i>	S29	20	B2
Interruptor - Nível de Fluido de Freio <i>Interruptor - Nivel de Fluido de Freno</i>	B1	15	C3
Interruptor - Porta Dianteira L.E. <i>Interruptor - Puerta Delantera L.I.</i>	S64	21	B3
Interruptor - Pressão de Óleo <i>Interruptor - Presión de Aceite</i>	S11	18	A4
Interruptor - Ventilador Interno <i>Interruptor - Ventilador Interior</i>	S70	16	B2
Interruptor - Ventilador Interno e Desembaçador do Vidro Traseiro <i>Interruptor - Ventilador Interior y Desempañador de la Luneta</i>	S69/S70	16	B2
Interruptor - Ventilador Interno e Desembaçador do Vidro Traseiro <i>Interruptor - Ventilador Interior y Desempañador de la Luneta</i>	S69/S70	24	B2
Interruptor da Buzina <i>Interruptor de la Bocina</i>	S3.7	20	C1
Interruptor de Ignição <i>Interruptor de Encendido</i>	S1	2	B2



Descrição Descripción	Código	Página	Localização Localización
Interruptor de Luz <i>Interruptor de Luz</i>	S2.1	20	C1
Interruptor de Marcha a Ré <i>Interruptor de Marcha Atrás</i>	S31	20	A1
Interruptor do Condicionador de Ar <i>Interruptor del Acondicionador de Aire</i>	S47	24	C2
Interruptor - Sinalizador de Emergência <i>Interruptor - Señalizador de Emergencia</i>	S6	19	B1
Interruptor - Sinalizador de Emergência <i>Interruptor - Señalizador de Emergencia</i>	S6	20	C1
Lâmpada - Acendedor de Cigarros <i>Bombilla - Encendedor de Cigarrillos</i>	E28	8	C2
Lâmpada - Compartimento de Passageiro <i>Bombilla - Habitáculo</i>	E16.1	21	B2
Lâmpada da Placa de Licença <i>Luz de la Placa de la Matrícula</i>	E5	20	B3
Lâmpada Indicadora de Advertência <i>Luz Indicadora de Advertencia</i>	H1.44	18	A2
Lâmpada Indicadora de Carga <i>Luz Indicadora de Carga</i>	H1.1	18	B2
Lâmpada Indicadora de Direção <i>Luz Señalizador de Giro</i>	H1.33	18	A2
Lâmpada Indicadora de Falha do Sistema de Injeção <i>Luz Indicadora de Falla del Sistema de Inyección</i>	H1.06	18	B2
Lâmpada Indicadora de Farol Alto <i>Luz Indicadora de Luz Alta</i>	H1.12	18	B2
Lâmpada Indicadora de Nível Baixo do Fluido de Freio e Freio de Estacionamento <i>Luz Indicadora de Nivel Bajo del Fluido de Freno y Freno de Estacionamiento</i>	H1.17	18	B2



Descrição Descripción	Código	Página	Localização Localización
Lâmpada Indicadora de Nível Baixo do Fluido de Freio e Freio de Estacionamento <i>Luz Indicadora de Nivel Bajo del Fluido de Freno y Freno de Estacionamiento</i>	H1.17	18	B2
Lâmpada Indicadora de Pressão de Óleo <i>Luz Indicadora de Presión de Aceite</i>	H1.02	18	B2
Lâmpada Indicadora de Temperatura <i>Luz Indicadora de Temperatura</i>	H1.16	18	B2
Lâmpada Indicadora do Desembaçador do Vidro Traseiro <i>Luz Indicadora del Desempañador del Limpialuneta</i>	H1.49	18	B2
Lâmpadas - Iluminação do Painel de Instrumentos <i>Luces - Alumbrado del Tablero de Instrumentos</i>	H1.21	18	B2
Lanterna Traseira Direita <i>Luz de Cola - Derecha</i>	E4.1	20	C3
Lanterna Traseira Esquerda <i>Luz de Cola Izquierda</i>	E3.1	20	B3
Maxi-Fusível - F2.2, F2.3 - 30A <i>Maxifusible - F2.2, F2.3 - 30A</i>	F2	2	A1
Maxi-Fusível - Controles do Motor - 20A <i>Maxifusible - Controles del Motor - 20A</i>	F1	2	A1
Maxi-Fusível - F4.7, F4.1, Interruptor de Luzes - 30A <i>Maxifusible - F4.7, F4.1, Interruptor de las Luces - 30A</i>	F4	2	A1
Maxi-Fusível - Interruptor de Ignição - 60A <i>Maxifusible - Interruptor de Encendido - 60A</i>	F5	2	B1
Maxi-Fusível - Interruptor do Ventilador Interno - 20A <i>Maxifusible - Interruptor del Ventilador Interior - 20A</i>	F5.14	2	B4
Maxi-Fusível - Relé do Ventilador do Radiador - Velocidade Baixa, Relé do Ventilador do Radiador - Velocidade Alta, F3.28 - 40A <i>Maxifusible - Relevador del Ventilador del Radiador - Velocidad Baja, Relevador del Ventilador del Radiador - Velocidad Alta, F3.28 - 40A</i>	F7	2	B1



Descrição Descripción	Código	Página	Localização Localización
Maxi-Fusível - Relés do Ventilador Interno, Relé do Ventilador do Radiador - Velocidade Baixa, Relé do Ventilador do Radiador - Velocidade Alta - 30A <i>Maxifusible - Relevadores del Ventilador Interior, Relevador del Ventilador del Radiador - Velocidad Baja, Relevador del Ventilador del Radiador - Velocidad Alta - 30A</i>	F3	2	A1
Mini-Fusível - Relé do Limpador do Pára-brisa, Relé do Limpador do Vidro Traseiro, Motor do Limpador do Pára-brisa, Interruptor do Limpador - 30A <i>Minifusible - Relevador del Limpiaparabrisas, Relevador del Limpialuneta, Motor del Limpiaparabrisas, Interruptor del Limpiador - 30A</i>	F5.16	2	D4
Mini-Fusível - Acendedor de Cigarros - 15A <i>Minifusible - Encendedor de Cigarrillos - 15A</i>	F5.18	3	A4
Mini-Fusível - Farol Alto LD, Luz Indicadora de Farol Alto - 10A <i>Minifusible - Luz alta LD, Luz Indicadora de Luz Alta - 10A</i>	F2.25	3	A4
Mini-Fusível - Farol Alto LE - 10A <i>Minifusible - Luz Alta L.I. - 10A</i>	F2.10	3	B4
Mini-Fusível - Farol Baixo LD - 10A <i>Minifusible - Luz Baja L.D. - 10A</i>	F2.27	3	B4
Mini-Fusível - Farol Baixo LE - 10A <i>Minifusible - Luz Baja L.I. - 10A</i>	F2.12	3	B4
Mini-Fusível - Iluminação do Interruptor do Ventilador Interno, Rádio, Iluminação do Painel de Instrumentos, Lanterna Dianteira LE, Lanterna Traseira LE - 10A <i>Minifusible - Alumbrado del Interruptor del Ventilador Interior, Radio, Alumbrado del Tablero de Instrumentos, Luz Delantera L.I., Luz de Cola L.I. - 10A</i>	F2.8	3	C4
Mini-Fusível - Iluminação do Painel de Instrumentos, Módulo de Controle do Imobilizador - 5A <i>Minifusible - Alumbrado del Tablero de Instrumentos, Módulo de Control del Inmovilizador - 5A</i>	F2.3	2	B4
Mini-Fusível - Interruptor de Emergência - Buzina - 10A <i>Minifusible - Interruptor de Emergencia - Bocina - 10A</i>	F4.7	3	D4
Mini-Fusível - Interruptor de Luz de Ré, Interruptor de Luz de Freio - 10A <i>Minifusible - Interruptor de la Luz de Marcha Atrás, Interruptor de la Luz de Freno - 10A</i>	F5.21	3	A4



Descrição Descripción	Código	Página	Localização Localización
Mini-Fusível - Interruptor do Desembaçador do Vidro Traseiro, Relé do Ventilador Interno, Interruptor do Ventilador Interno, Interruptor de Pressão do A/C - 5A <i>Minifusible - Interruptor del Desempañador de la Luneta, Relevador del Ventilador Interior, Interruptor del Ventilador Interior, Interruptor de Presión del A/C - 5A</i>	F5.6	2	C4
Mini-Fusível - Interruptor do Indicador de Direção, Emergência, Rádio, Sensor de Velocidade - 10A <i>Minifusible - Interruptor del Señalizador de Giro, Emergencia, Radio, Sensor de Velocidad - 10A</i>	F5.17	2	D4
Mini-Fusível - Luz da Placa de Licença, Lanterna Traseira LD, Lanterna Dianteira LD - 10A <i>Minifusible - Luz de la Placa de Matrícula, Luz de Cola L.D., Lanterna Delantera LD - 10A</i>	F2.23	3	C4
Mini-Fusível - Luz Interna, Rádio - 10A <i>Minifusible - Luz Interior, Radio - 10A</i>	F2.2	2	B4
Mini-Fusível - Módulo de Controle do Imobilizador, Iluminação do Painel de Instrumentos, Relé do Compressor do A/C - 5A <i>Minifusible - Módulo de Control del Inmovilizador, Alumbrado del Tablero de Instrumentos, Relevador del Compresor del A/C - 5A</i>	F5.4	2	C4
Mini-Fusível - Relé da Bomba de Combustível - Módulo de Controle do Motor, Bobina de Ignição - 15A <i>Minifusible - Relevador de la Bomba de Combustible - Módulo de Control del Motor, Bobina de Encendido - 15A</i>	F5.19	4	C3
Mini-Fusível - Relé do Compressor do A/C - 15A <i>Minifusible - Relevador del Compresor del A/C - 15A</i>	F3.26	5	C2
Mini-Fusível - Relé do Desembaçador do Vidro Traseiro - 30A <i>Minifusible - Relevador del Desempañador de la Luneta - 30A</i>	F4.1	5	A4
Mini-Fusível - Relé do Ventilador do Radiador - Velocidade Baixa, Relé do Ventilador do Radiador - Velocidade Alta - 5A <i>Minifusible - Relevador del Ventilador del Radiador - Velocidad Baja, Relevador del Ventilador del Radiador - Velocidad Alta - 5A</i>	F3.28	4	A3
Módulo - Imobilizador <i>Módulo - Inmovilizador</i>	A17	22	B2
Módulo de Controle (Multec) <i>Módulo de Control (Multec)</i>	A4	9	B2
Motor - Ventilador Interno <i>Motor - Ventilador Interior</i>	M12	16	C3



Descrição Descripción	Código	Página	Localização Localización
Motor de Partida <i>Motor de Arranque</i>	M1	12	A4
Motor do Limpador do Pára-brisa <i>Motor del Limpiaparabrisas</i>	M16	19	A3
Motor do Limpador do Vidro Traseiro <i>Motor del Limpialuneta</i>	M17	19	C3
Motor do Ventilador do Radiador <i>Motor del Ventilador del Radiador</i>	M19	13	C3
Motor do Ventilador do Radiador (A/C) <i>Motor del Ventilador del Radiador (A/C)</i>	M20	13	B3
Motor Escalonador da Borboleta de Aceleração <i>Motor de Paso de la Mariposa de Aceleración</i>	M24	10	C4
Motor - Ventilador Interno (A/C) <i>Motor - Ventilador Interior (A/C)</i>	M13	24	C3
Painel de Instrumentos <i>Tablero de Instrumentos</i>	H1	18	B2
Pré-Resistor - Ventilador Interno (Com A/C) <i>Resistor Previo - Ventilador Interior (Con A/C)</i>	R21	24	B3
Pré-Resistor - Ventilador Interno (Sem A/C) <i>Resistor Previo - Ventilador Interior (Sin A/C)</i>	R11	16	B3
Rádio Radio	A14	23	B3
Relé - Bomba de Combustível <i>Relevador - Bomba de Combustible</i>	K16	4	B3
Relé - Desembaçador do Vidro Traseiro <i>Relevador - Desempañador de la Luneta</i>	K3	5	A3
Relé - Luz Indicadora de Direção <i>Relevador - Luz Señalizadora de Giro</i>	K30	5	B3



Descrição Descripción	Código	Página	Localização Localización
Relé do Compressor A/C <i>Relevador del Compresor A/C</i>	K36	5	D3
Relé do Limpador do Pára-brisa <i>Relevador del Limpiaparabrisas</i>	K10	4	D3
Relé do Limpador do Vidro Traseiro <i>Relevador del Limpialuneta</i>	K6	4	C3
Relé do Ventilador Interno <i>Relevador del Ventilador Interior</i>	K43.1	5	B3
Relé do Ventilador Interno <i>Relevador del Ventilador Interior</i>	K43.3	5	D3
Relé - Motor do Ventilador do Radiador (1 Estágio) <i>Relevador - Motor del Ventilador del Radiador (1 Etapa)</i>	K13.2	4	A3
Relé - Motor do Ventilador do Radiador (2 Estágios) <i>Relevador - Motor del Ventilador del Radiador (2 Etapas)</i>	K13.1	4	A3
Sensor - Temperatura do Líquido de Arrefecimento <i>Sensor - Temperatura del Líquido de Enfriamiento</i>	B107	10	C4
Sensor de Detonação <i>Sensor de Detonación</i>	B30	9	A2
Sensor de Pressão (Transdutor) - Condicionador de Ar <i>Sensor de Presión (Transductor) - Acondicionador de Aire</i>	B29	9	A1
Sensor de Rotação da Árvore de Manivelas <i>Sensor de Revolución del Cigüeñal</i>	B34	9	D4
Sensor de Velocidade (Sem ABS) <i>Sensor de Velocidad (Sin ABS)</i>	B24	10	B2
Sensor Lambda (Não Aquecido) <i>Sensor Lambda (No calentado)</i>	B53	10	A4
Sensor de Posição da Borboleta - TPS <i>Sensor de Posición de la Mariposa de Aceleración - TPS</i>	B45	10	D4



Descrição Descripción	Código	Página	Localização Localización
Sensor de Temperatura e Pressão do Ar <i>Sensor de Temperatura y de Presión de Aire</i>	B69	10	B4
Válvula Injetora - Cilindro 1 <i>Válvula de Inyección - Cilindro 1</i>	Y9.1	9	B4
Válvula Injetora - Cilindro 2 <i>Válvula de Inyección - Cilindro 2</i>	Y9.2	9	B4
Válvula Injetora - Cilindro 3 <i>Válvula de Inyección - Cilindro 3</i>	Y9.3	9	C4
Válvula Injetora - Cilindro 4 <i>Válvula de Inyección - Cilindro 4</i>	Y9.4	9	C4
Válvula Solenóide - Ventilação do Reservatório de Combustível <i>Válvula Solenoide - Ventilación del Tanque de Combustible</i>	Y5	9	A4



